

Brief Operating Instructions

Cerabar M

PMC51, PMP51, PMP55

Process pressure measurement
4 to 20 mA Analog

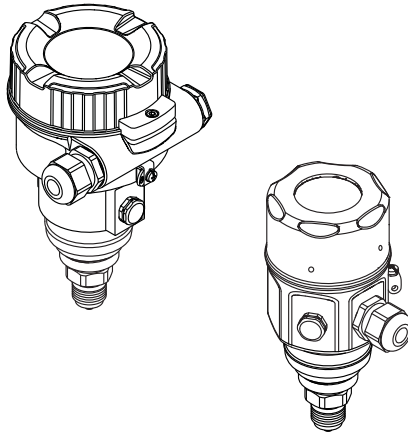

These Instructions are Brief Operating Instructions; they are not a substitute for the Operating Instructions pertaining to the device.

Detailed information about the device can be found in the Operating Instructions and the other documentation:

Available for all device versions via:

- Internet: www.endress.com/deviceviewer
- Smart phone/tablet: *Endress+Hauser Operations App*

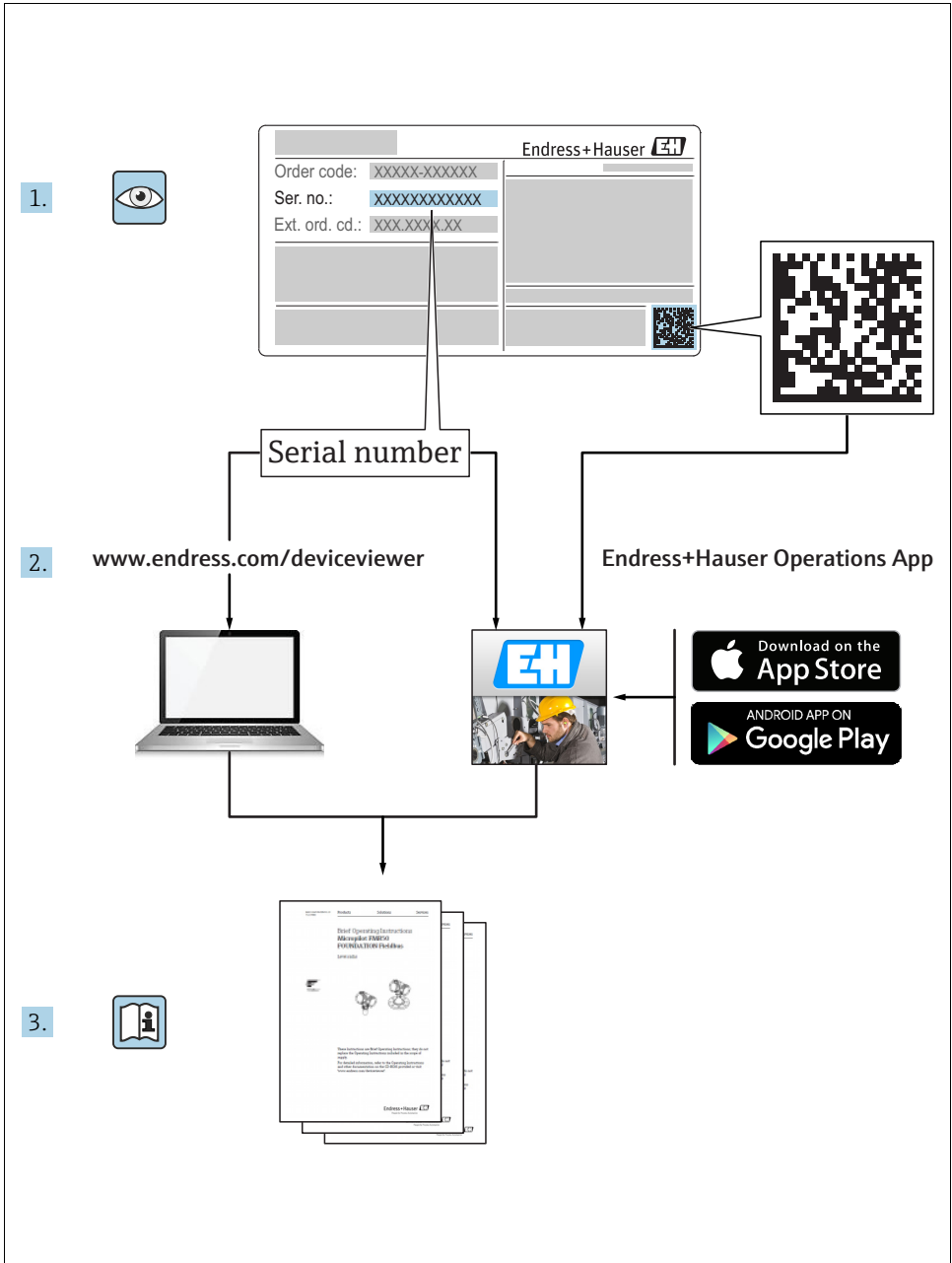

Table of contents

1	Document information	4
1.1	Document function	4
1.2	Symbols used	4
2	Basic safety instructions	6
2.1	Requirements for personnel	6
2.2	Designated use	7
2.3	Occupational safety	7
2.4	Operational safety	7
2.5	Hazardous area	7
2.6	Product safety	8
3	Identification	8
3.1	Product identification	8
3.2	Scope of delivery	8
3.3	CE mark, Declaration of Conformity	8
4	Installation	9
4.1	Incoming acceptance	9
4.2	Storage and transport	9
4.3	Installation conditions	9
4.4	General installation instructions	9
4.5	Installation instructions	10
4.6	Closing the housing covers	15
4.7	Mounting the profiled seal for the universal process adapter	16
4.8	Post-installation check	16
5	Electrical connection	16
5.1	Connecting the device	16
5.2	Connecting the measuring unit	19
5.3	Potential equalization	20
5.4	Overvoltage protection (optional)	20
5.5	Post-connection check	21
6	Operation	21
6.1	Position of operating elements	21
6.2	Using the device display (optional)	22
7	Commissioning	24
7.1	Function check	25
7.2	Commissioning	25





1 Document information

1.1 Document function







These Operating Instructions contain all the information that is required in the various phases of the life cycle of the device: from product identification, incoming acceptance and storage, to mounting, connection, operation and commissioning through to troubleshooting, maintenance and disposal.

1.2 Symbols used



1.2.1 Safety symbols

Symbol	Meaning
 <small>A0011189-EN</small>	DANGER! This symbol alerts you to a dangerous situation. Failure to avoid this situation will result in serious or fatal injury.
 <small>A0011190-EN</small>	WARNING! This symbol alerts you to a dangerous situation. Failure to avoid this situation can result in serious or fatal injury.
 <small>A0011191-EN</small>	CAUTION! This symbol alerts you to a dangerous situation. Failure to avoid this situation can result in minor or medium injury.
 <small>A0011192-EN</small>	NOTE! This symbol contains information on procedures and other facts which do not result in personal injury.









1.2.2 Electrical symbols

Symbol	Meaning	Symbol	Meaning
	Direct current		Alternating current
	Direct current and alternating current		Ground connection A grounded terminal which, as far as the operator is concerned, is grounded via a grounding system.
	Protective ground connection A terminal which must be connected to ground prior to establishing any other connections.		Equipotential connection A connection that has to be connected to the plant grounding system: This may be a potential equalization line or a star grounding system depending on national or company codes of practice.

1.2.3 Tool symbols

Symbol	Meaning
 A0011221	Allen screw
 A0011222	Open-ended wrench

1.2.4 Symbols for certain types of information

Symbol	Meaning
 A0011182	Permitted Indicates procedures, processes or actions that are permitted.
 A0011184	Forbidden Indicates procedures, processes or actions that are forbidden.
 A0011193	Tip Indicates additional information.
 A0015482	Reference to documentation
 A0015484	Reference to page.
 A0015487	Reference to graphic
1. , 2. , ...	Series of steps
 A0018343	Result of a sequence of actions
 A0015502	Visual inspection

1.2.5 Symbols in graphics

Symbol	Meaning
1, 2, 3, 4 etc.	Numbering for main items
1., 2., ...	Series of steps
A, B, C, D etc.	Views

1.2.6 Symbols on the device

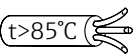
Symbol	Meaning
	Safety instructions Observe the safety instructions in the associated Operating Instructions.
	Connecting cable immunity to temperature change Indicates that the connecting cables have to withstand a temperature of 85°C at least.

1.2.7 Registered trademarks

KALREZ[®], VITON[®], TEFLON[®]

Trademark of E.I. Du Pont de Nemours & Co., Wilmington, USA

TRI-CLAMP[®]

Trademark of Ladish & Co., Inc., Kenosha, USA

GORE-TEX[®]

Trademark of W.L. Gore & Associates, Inc., USA

2 Basic safety instructions

2.1 Requirements for personnel

Personnel involved in installation, commissioning, diagnostics and maintenance must meet the following requirements:

- Trained, qualified specialists must have a relevant qualification for this specific function and task
- Are authorized by the plant owner/operator
- Are familiar with national regulations
- Before commencing work, the specialist staff must have read and understood the instructions in the manuals and supplementary documentation as well as in the certificates (depending on the application)

- Follow instructions and comply with basic conditions

Operating personnel must meet the following requirements:

- Are instructed and authorized according to the requirements of the task by the facility's owner-operator
- Follow the instructions in these Operating Instructions

2.2 Designated use

The Cerabar M is a pressure transmitter for measuring pressure and level.

2.2.1 Incorrect use

The manufacturer is not liable for damage caused by improper or non-designated use.

Clarification of borderline cases:

In the case of special fluids and fluids used for cleaning, Endress+Hauser is glad to provide assistance in clarifying the corrosion resistance of wetted materials, but does not accept any warranty or liability.

2.3 Occupational safety

When working on and with the device:

- Wear the required personal protective equipment according to national regulations.
- Switch off the supply voltage before connecting the device.

2.4 Operational safety

Risk of injury!

- ▶ Operate the device in a proper technical condition and fail-safe condition only.
- ▶ The operator is responsible for the trouble-free operation of the device.

Modifications to the device

Unauthorized modifications to the device are not permitted and can lead to unforeseeable dangers:

- ▶ If modifications are nevertheless required, consult with Endress+Hauser.

Repair

To ensure continued operational safety:

- ▶ Carry out repairs on the device only if they are expressly permitted.
- ▶ Observe national regulations pertaining to the repair of an electrical device.
- ▶ Only use genuine spare parts and accessories from Endress+Hauser.

2.5 Hazardous area

To eliminate the risk of danger to persons or the facility when the device is used in the hazardous area (e.g. explosion protection, pressure equipment safety):

- Check the nameplate to determine whether the ordered device can be used for the intended application in the hazardous area.

- Observe the specifications in the separate supplementary documentation that is an integral part of these Operating Instructions.

2.6 Product safety

This measuring device is designed in accordance with good engineering practice to meet state-of-the-art safety requirements, has been tested, and left the factory in a condition in which it is safe to operate. It meets general safety standards and legal requirements. It also complies with the EC directives listed in the device-specific EC Declaration of Conformity. Endress+Hauser confirms this by affixing the CE mark to the device.

3 Identification

3.1 Product identification

The following options are available to identify the measuring device:

- Nameplate specifications
- Order code with a breakdown of the device features on the delivery note
- Enter serial number from nameplates in the W@M Device Viewer (www.endress.com/deviceviewer): All information about the measuring device is displayed.

For an overview of the technical documentation provided, enter the serial number from the nameplates in the W@M Device Viewer (www.endress.com/deviceviewer).

3.2 Scope of delivery

The scope of delivery comprises:

- Device
- Optional accessories

Documentation supplied:

- Operating Instructions BA00385P are available on the Internet.
→ See: www.de.endress.com → Download
- Brief Operating Instructions: KA01036P
- Final inspection report
- Optional: factory calibration form, test certificates

3.3 CE mark, Declaration of Conformity

The devices are designed to meet state-of-the-art safety requirements, have been tested and left the factory in a condition in which they are safe to operate. The devices comply with the applicable standards and regulations as listed in the EC Declaration of Conformity and thus comply with the statutory requirements of the EC Directives.

Endress+Hauser confirms the conformity of the device by affixing to it the CE mark.

4 Installation

4.1 Incoming acceptance

- Check the packaging and the contents for damage.
- Check the shipment, make sure nothing is missing and that the scope of supply matches your order.

4.2 Storage and transport

4.2.1 Storage

The device must be stored in a dry, clean area and protected against damage from impact (EN 837-2).

Storage temperature range:

See Technical Information for Cerabar M TI00436P.

4.2.2 Transport

WARNING

Incorrect transportation

Housing, diaphragm and capillaries may become damaged, and there is a risk of injury!

- ▶ Transport the measuring device to the measuring point in its original packaging or by the process connection.
- ▶ Follow the safety instructions and transport conditions for devices weighing more than 18 kg (39.6 lbs).
- ▶ Do not use capillaries as a carrying aid for the diaphragm seals.

4.3 Installation conditions

4.3.1 Dimensions

For dimensions, please refer to the Technical Information for Cerabar M TI00436P, "Mechanical construction" section.

4.4 General installation instructions

- Devices with a G 1 1/2 thread:
When screwing the device into the tank, the flat seal has to be positioned on the sealing surface of the process connection. To avoid additional strain on the process isolating diaphragm, the thread should never be sealed with hemp or similar materials.
- Devices with NPT threads:
 - Wrap Teflon tape around the thread to seal it.
 - Tighten the device at the hexagonal bolt only. Do not turn at the housing.
 - Do not overtighten the thread when screwing. Max. torque: 20 to 30 Nm (14.75 to 22.13 lbf ft)

4.4.1 Mounting sensor modules with PVDF thread

⚠ WARNING

Risk of damage to process connection!

Risk of injury!

- ▶ Sensor modules with PVDF process connections with threaded connection must be installed with the mounting bracket provided!



⚠ WARNING

Material fatigue from pressure and temperature!

Risk of injury if parts burst! The thread can become loose if exposed to high pressure and temperatures.

- ▶ The integrity of the thread must be checked regularly and the thread may need to be re-tightened with the maximum tightening torque of 7 Nm (5.16 lbf ft). Teflon tape is recommended for sealing the ½" NPT thread.

4.5 Installation instructions

- Due to the orientation of the Cerabar M, there may be a shift in the zero point, i.e. when the container is empty or partially full, the measured value does not display zero. You can correct this zero point shift →  22, → Chap. 6.1.2 "Function of the operating elements".
- For PMP55, please refer to → Chap. 4.5.2 "Installation instructions for devices with diaphragm seals – PMP55", →  12.
- Endress+Hauser offers a mounting bracket for installing on pipes or walls.
→  13, → Chap. 4.5.5 "Wall and pipe mounting (optional)".

4.5.1 Installation instructions for devices without diaphragm seals – PMP51, PMC51

NOTICE

Damage to the device!

If a heated Cerabar M is cooled during the cleaning process (e.g. by cold water), a vacuum develops for a short time, whereby moisture can penetrate the sensor through the pressure compensation (1).

- ▶ If this is the case, mount the Cerabar M with the pressure compensation (1) pointing downwards.

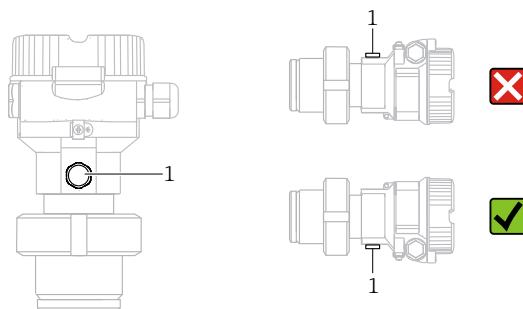

- Keep the pressure compensation and GORE-TEX® filter (1) free from contamination.
- Cerabar M transmitters without diaphragm seals are mounted as per the norms for a manometer (DIN EN 837-2). We recommend the use of shutoff devices and siphons. The orientation depends on the measuring application.
- Do not clean or touch process isolating diaphragms with hard or pointed objects.
- The device must be installed as follows in order to comply with the cleanability requirements of the ASME-BPE (Part SD Cleanability):

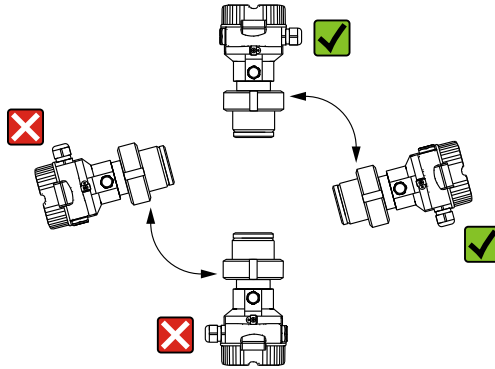

Pressure measurement in gases

Mount the Cerabar M with the shutoff device above the tapping point so that any condensate can flow into the process.

Pressure measurement in steams

- Mount Cerabar M with siphon above the tapping point.
- Fill the siphon with liquid before commissioning.
The siphon reduces the temperature to almost the ambient temperature.

Pressure measurement in liquids

- Mount Cerabar M with shutoff device below or at the same level as the tapping point.

Level measurement

- Always install the Cerabar M below the lowest measuring point.
- Do not mount the device in the filling curtain or at a point in the tank which could be affected by pressure pulses from an agitator.
- Do not mount the device in the suction area of a pump.
- The calibration and functional test can be carried out more easily if you mount the device downstream of a shutoff device.

4.5.2 Installation instructions for devices with diaphragm seals – PMP55

- Cerabar M devices with diaphragm seals are screwed in, flanged or clamped, depending on the type of diaphragm seal.
- Please note that the hydrostatic pressure of the liquid columns in the capillaries can cause zero point shift. The zero point shift can be corrected.
- Do not clean or touch the process isolating diaphragm of the diaphragm seal with hard or pointed objects.
- Do not remove process isolating diaphragm protection until shortly before installation.

NOTICE

Improper handling!

Damage to the device!

- ▶ A diaphragm seal and the pressure transmitter together form a closed, oil-filled calibrated system. The fill fluid hole is sealed and may not be opened.
- ▶ When using a mounting bracket, sufficient strain relief must be ensured for the capillaries in order to prevent the capillary bending down (bending radius ≥ 100 (3.94 in)).
- ▶ Please observe the application limits of the diaphragm seal filling oil as detailed in the Technical Information for Cerabar M TI00436P, "Planning instructions for diaphragm seal systems" section.

NOTICE

In order to obtain more precise measurement results and to avoid a defect in the device, mount the capillaries as follows:

- ▶ Vibration-free (in order to avoid additional pressure fluctuations)
- ▶ Not in the vicinity of heating or cooling lines
- ▶ Insulate if the ambient temperature is below or above the reference temperature
- ▶ With a bending radius of ≥ 100 mm (3.94 in).
- ▶ Do not use the capillaries as a carrying aid for the diaphragm seals!

Vacuum application

See operating instructions.

Mounting with temperature isolator

See operating instructions.

4.5.3 Seal for flange mounting

NOTICE**Corrupted measurement results.**

The seal is not allowed to press against the process isolating diaphragm as this could affect the measurement result.

- Ensure that the seal is not touching the process isolating diaphragm.

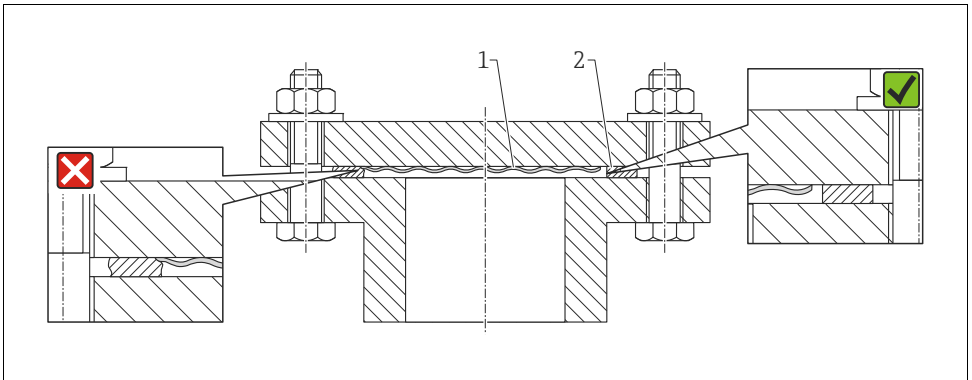

A0017743

Fig. 1:

1 Process isolating diaphragm

2 Seal

4.5.4 Thermal insulation – PMP55

See operating instructions.

4.5.5 Wall and pipe mounting (optional)

See operating instructions.

4.5.6 Assembling and mounting the "separate housing" version

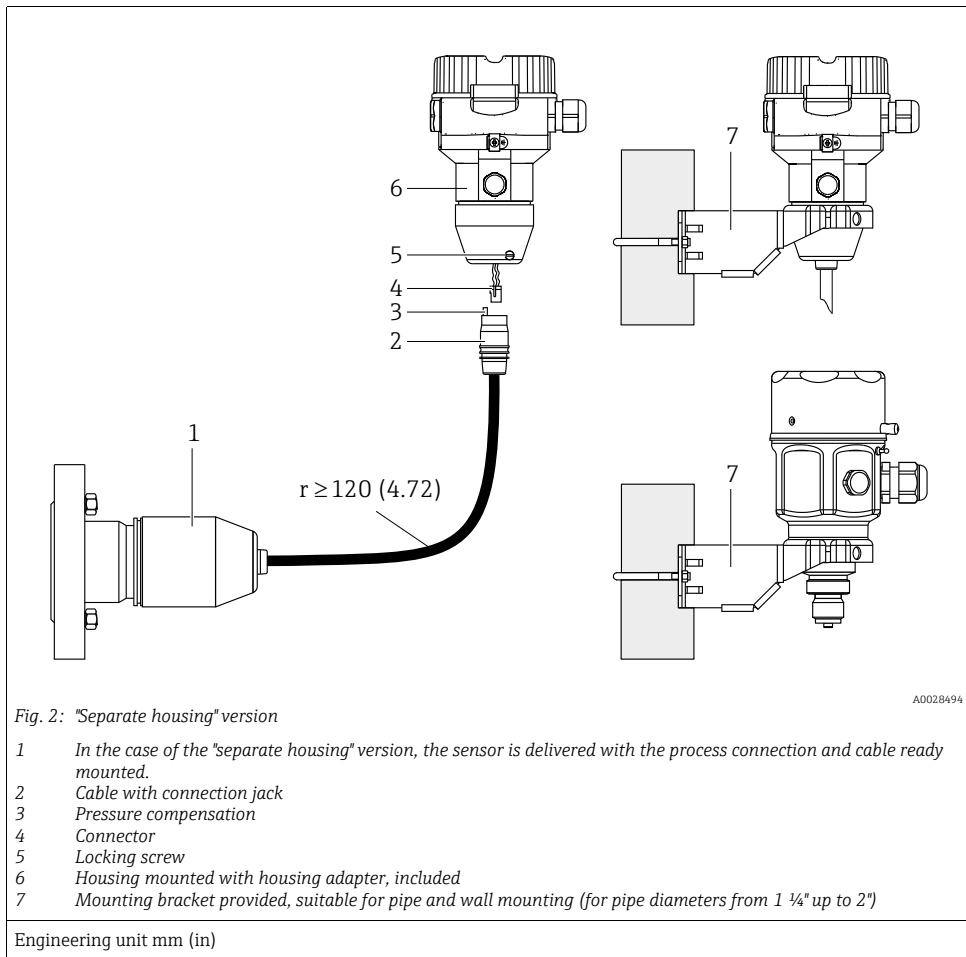

Assembly and mounting

1. Insert the connector (item 4) into the corresponding connection jack of the cable (item 2).
2. Plug the cable into the housing adapter (item 6).
3. Tighten the locking screw (item 5).
4. Mount the housing on a wall or pipe using the mounting bracket (item 7).
 When mounting on a pipe, tighten the nuts on the bracket uniformly with a torque of at least 5 Nm (3.69 lbs ft).
 Mount the cable with a bending radius (r) \geq 120 mm (4.72 in).

Routing the cable (e.g. through a pipe)

You require the cable shortening kit.

Order number: 71093286

For details on mounting, see SD00553P/00/A6.

4.5.7 PMP51, version prepared for diaphragm seal mount – welding recommendation

See operating instructions.

4.6 Closing the housing covers

NOTICE

Devices with EPDM cover seal - transmitter leakiness!

Mineral-based, animal-based or vegetable-based lubricants cause the EPDM cover seal to swell and the transmitter to become leaky.

- ▶ The thread is coated at the factory and therefore does not require any lubrication.

NOTICE

The housing cover can no longer be closed.

Damaged thread!

- ▶ When closing the housing covers make sure that the threads on the covers and the housing are free from dirt, such as sand. If you encounter resistance when closing the covers, then check the threads again for dirt.

4.6.1 Closing the cover on the stainless steel housing



Abb. 3: Closing the cover

A0028497

The cover for the electronics compartment is tightened by hand at the housing until the stop. The screw serves as DustEx protection (only on devices with DustEx approval).

4.7 Mounting the profiled seal for the universal process adapter

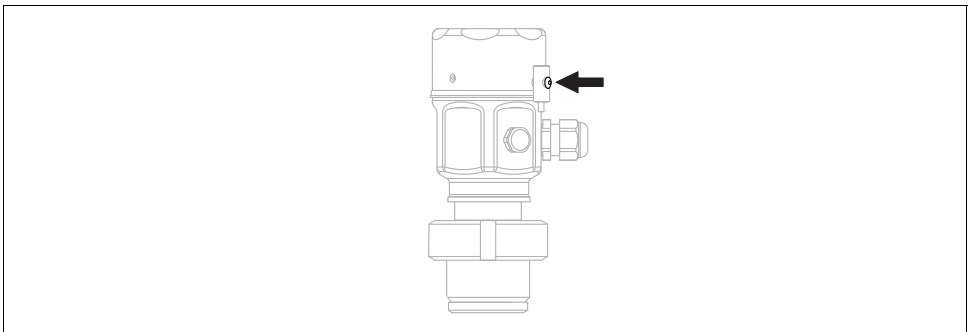
For details on mounting, see KA00096F/00/A3.

4.8 Post-installation check

0	Is the device undamaged (visual inspection)?
0	Does the device comply with the measuring point specifications? For example: <ul style="list-style-type: none"> ■ Process temperature ■ Process pressure ■ Ambient temperature range ■ Measuring range
0	Are the measuring point identification and labeling correct (visual inspection)?
0	Is the device adequately protected against precipitation and direct sunlight?
0	Are the securing screw and securing clamp tightened securely?

5 Electrical connection

5.1 Connecting the device

⚠ WARNING

Supply voltage might be connected!

Risk of electric shock and/or explosion!

- ▶ Ensure that no uncontrolled processes are activated in the system.
- ▶ Switch off the supply voltage before connecting the device.
- ▶ When using the measuring device in hazardous areas, installation must comply with the corresponding national standards and regulations and the Safety Instructions or Installation or Control Drawings.
- ▶ A suitable circuit breaker must be provided for the device in accordance with IEC/EN61010.
- ▶ Devices with integrated overvoltage protection must be grounded.
- ▶ Protective circuits against reverse polarity, HF influences and overvoltage peaks are integrated.

Connect the device in the following order:

1. Check that the supply voltage corresponds to the supply voltage indicated on the nameplate.
2. Switch off the supply voltage before connecting the device.
3. Remove housing cover.
4. Guide the cable through the gland. Preferably use a twisted, shielded two-wire cable.

5. Connect the device in accordance with the following diagram.
6. Screw down the housing cover.
7. Switch on the supply voltage.

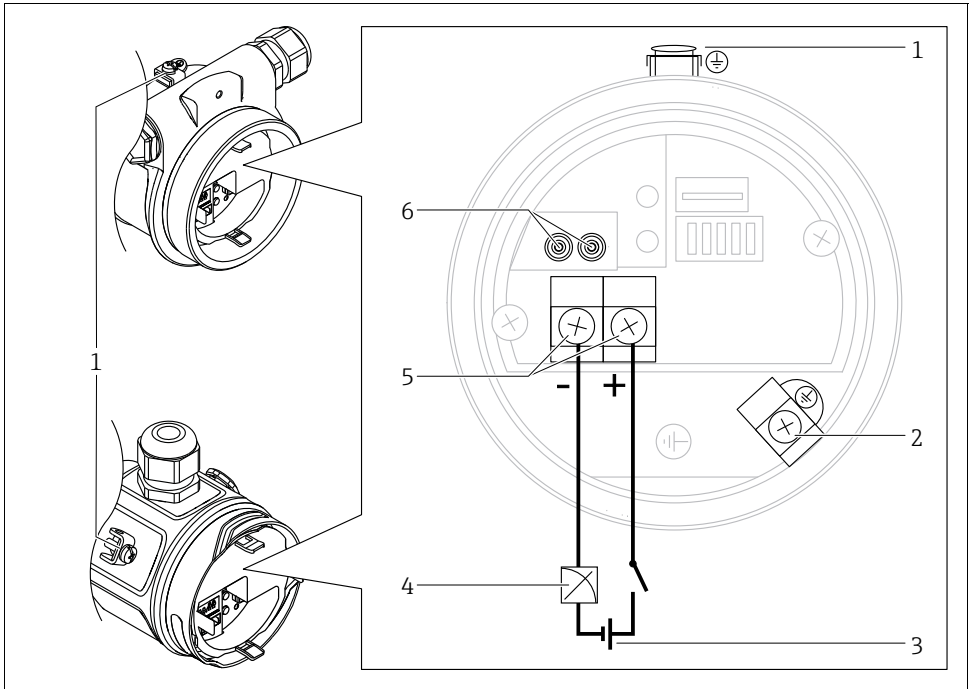

Electrical connection 4 to 20 mA

A002B498

- 1 External grounding terminal
- 2 Internal grounding terminal
- 3 Supply voltage: 11.5 to 45 VDC (versions with plug-in connectors 35 V DC)
- 4 4 to 20 mA
- 5 Terminals for supply and signal
- 6 Test terminals

5.1.1 Devices with M12 connector

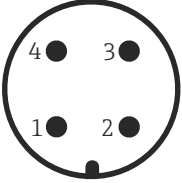
PIN assignment for M12 connector	PIN	Meaning
	1	Signal +
	2	Not assigned
	3	Signal -
	4	Earth

A0011175

5.1.2 Devices with 7/8" plug

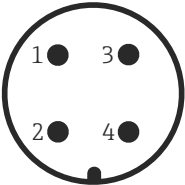
PIN assignment for 7/8" connector	PIN	Meaning
	1	Signal -
	2	Signal +
	3	Not assigned
	4	Shield

A0011176

5.1.3 Connecting the cable version

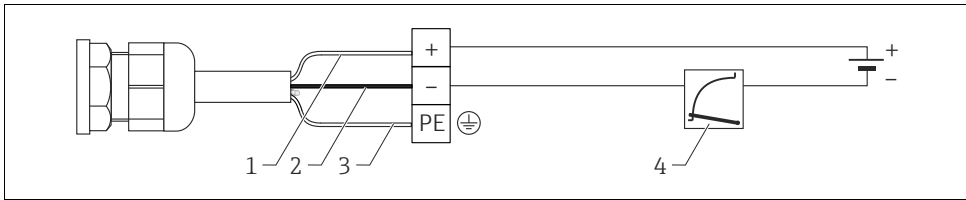

Fig. 4:

- 1 rd = red
- 2 bk = black
- 3 grnye = green
- 4 4 to 20 mA

A0019991

5.2 Connecting the measuring unit

5.2.1 Supply voltage

Electronic version	
4 to 20 mA	11.5 to 45 V DC (Versions with plug-in connectors: 35 V DC)

Taking 4 to 20 mA test signal

A 4 to 20 mA test signal may be measured via the test terminals without interrupting the measurement. To keep the corresponding measured error below 0.1 %, the current measuring device should exhibit an internal resistance of $< 0.7 \Omega$.

5.2.2 Terminals

- Supply voltage and internal ground terminal: 0.5 to 2.5 mm² (20 to 14 AWG)
- External ground terminal: 0.5 to 4 mm² (20 to 12 AWG)

5.2.3 Cable specification

- Endress+Hauser recommends using twisted, shielded two-wire cables.
- Cable outer diameter: 5 to 9 mm (0.2 to 0.35 in) depending on the cable gland used (see Technical Information)

5.2.4 Load



Abb. 5: Load diagram

1 Power supply 11.5 to 45 V DC (versions with plug-in connector 35 V DC) for other types of protection and for uncertified device versions

2 R_{Lmax} Maximum load resistance
 U Supply voltage

5.2.5 Shielding/potential equalization

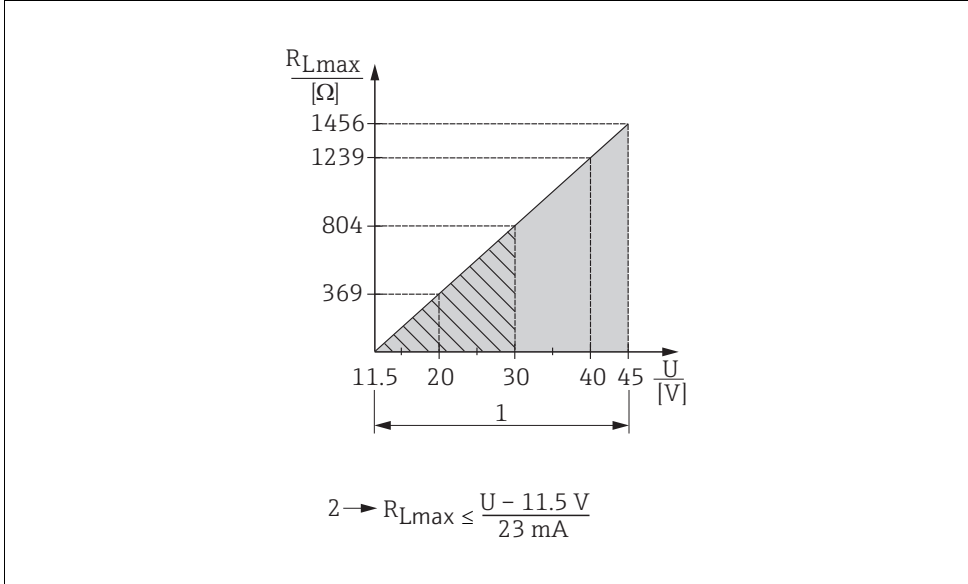
You achieve optimum shielding against disturbances if the shielding is connected on both sides (in the cabinet and on the device). If potential equalization currents are expected in the plant, only ground shielding on one side, preferably at the transmitter.

5.3 Potential equalization

Observe the applicable regulations.

5.4 Overvoltage protection (optional)

See operating instructions.

5.5 Post-connection check

Perform the following checks after completing electrical installation of the device:

- Does the supply voltage match the specifications on the nameplate?
- Is the device properly connected?
- Are all screws firmly tightened?
- Is the housing cover screwed down tight?

As soon as voltage is applied to the device, the green LED on the electronic insert lights up for a few seconds or the connected local display lights up.

6 Operation

6.1 Position of operating elements

The operating keys and the DIP switch are located on the electronic insert in the device.

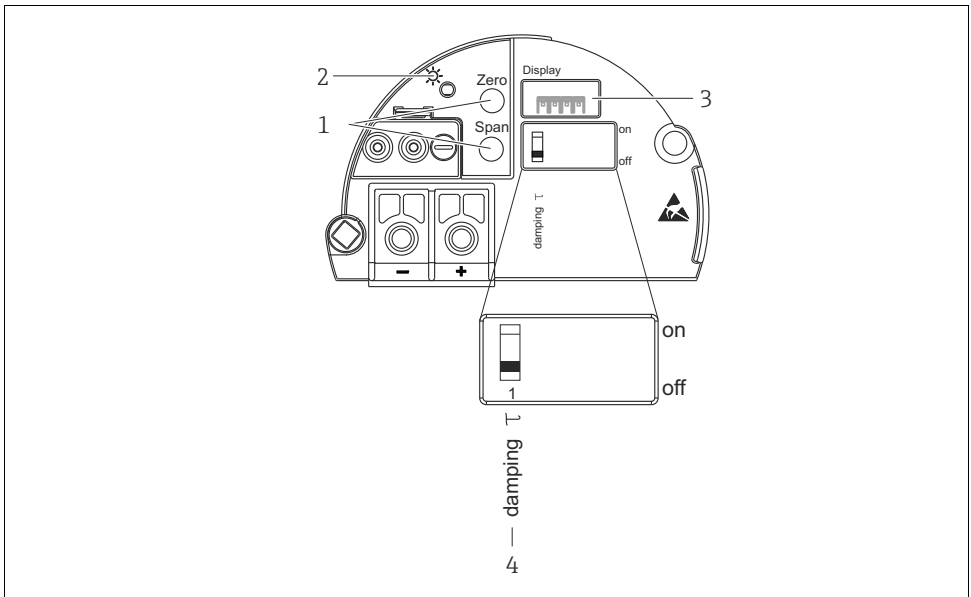

Fig. 6: Electronic insert

A0023992

- 1 Operating keys for lower range value (zero) and upper range value (span)
- 2 Green LED to indicate successful operation
- 3 Slot for optional local display
- 4 DIP switch for switching damping on/off

6.1.1 Function of the DIP switch

Switch position	
"off"	"on"
Damping is switched off. The output signal follows measured value changes without any delay.	Damping is switched on. The output signal follows measured value changes with the delay time t (Factory setting: t = 2 s or as per order specifications).

6.1.2 Function of the operating elements

Operating key(s)	Meaning
"Zero" pressed briefly	Display lower range value
"Zero" pressed for at least 3 seconds	Get lower range value The pressure present is accepted as the lower range value (LRV).
"Span" pressed briefly	Display upper range value
"Span" pressed for at least 3 seconds	Get upper range value The pressure present is accepted as the upper range value (LRV).
"Zero" and "Span" pressed together briefly	Display position adjustment
"Zero" and "Span" pressed simultaneously for at least 3 seconds	Position adjustment The sensor characteristic curve is shifted parallel to itself, so that the pressure present becomes the zero value.
"Zero" and "Span" pressed simultaneously for at least 12 seconds	Reset All parameters are reset to the order configuration.

6.2 Using the device display (optional)

A 4-line liquid crystal display (LCD) is used. The local display shows measured values, fault messages and notice messages.

The display can be removed for easy operation (see diagram, steps 1 - 3). It is connected to the device via a 90 mm (3.54 in) long cable.

The device display can be rotated in 90 ° stages (see diagram, steps 4 - 6).

Depending on the orientation of the device, this makes it easy to read the measured values.

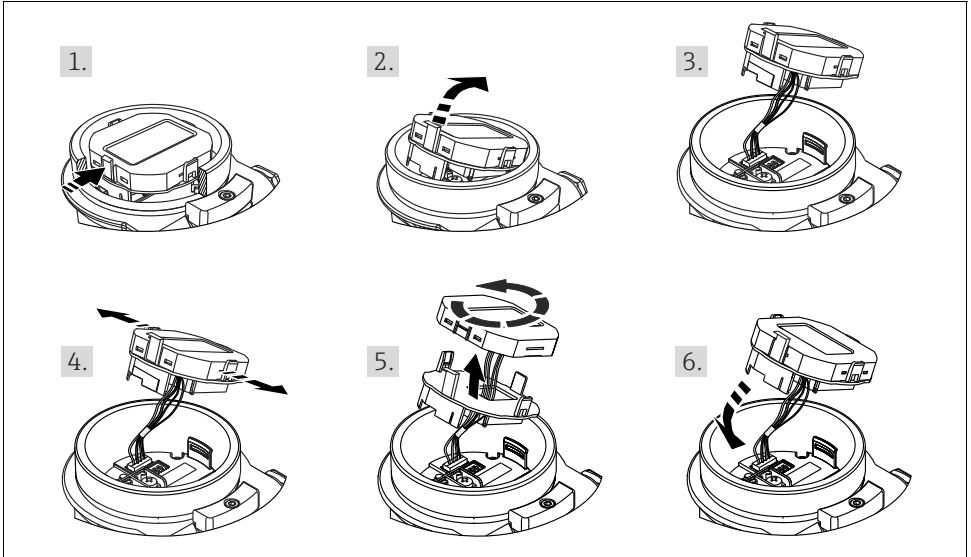

A0028500

Functions:

- 8-digit measured value display including sign and decimal point, bar graph for 4 to 20 mA as current display.
- Diagnostic functions (fault and warning message etc.)

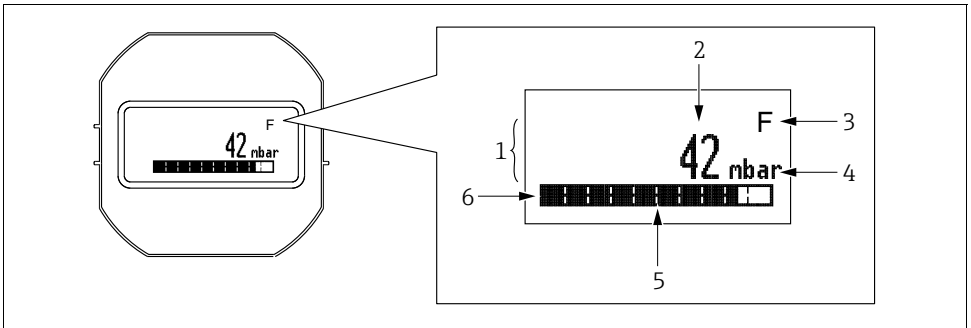

A0028501

Fig. 7: Display

- 1 Main line
- 2 Value
- 3 Symbol
- 4 Unit
- 5 Bar graph
- 6 Information line

The following table illustrates the symbols that can appear on the local display. Four symbols can occur at one time.

Symbol	Meaning
S	Error message "Out of specification" The device is being operated outside its technical specifications (e.g. during warmup or cleaning processes).
C	Error message "Service mode" The device is in the service mode (during a simulation, for example).
M	Error message "Maintenance required" Maintenance is required. The measured value remains valid.
F	Error message "Failure detected" An operating error has occurred. The measured value is no longer valid.

7 Commissioning

The device is factory-configured for the pressure measuring mode. The measuring range and the unit in which the measured value is transmitted correspond to the specifications on the nameplate.

⚠ WARNING

Permitted process pressure exceeded!

Risk of injury if parts burst! Warnings are displayed if the pressure is too high.

- ▶ If a pressure that is greater than the maximum permitted pressure is present at the device, the message "S" and "Warning" are output alternately. Only operate the device within the sensor range limits!

NOTICE



Permitted process pressure undershot!

Messages are displayed if the pressure is too low.

- ▶ If a pressure that is lower than the minimum permitted pressure is present at the device, the message "S" and "Warning" are output alternately. Only operate the device within the sensor range limits!

7.1 Function check

Carry out a post-installation and a post-connection check as per the checklist before commissioning the device.

- "Post-installation check" →  16 checklist
- "Post-connection check" →  21 checklist

7.2 Commissioning

The following functions are possible via the keys on the electronic insert:

- Position adjustment (zero point correction). A pressure shift resulting from the orientation of the measuring device can be corrected by performing the position adjustment.
- Setting lower range value and upper range value
- Device reset
- The pressure applied must be within the nominal pressure limits of the sensor. See information on the nameplate.

1.) Perform position adjustment	
Pressure is present at device.	
↓	
Press the "Zero" and "Span" keys simultaneously for at least 3 s.	
↓	
Does the LED on the electronic insert light up briefly?	
Yes	No
↓	↓
Applied pressure for position adjustment has been accepted.	Applied pressure for position adjustment has not been accepted. Observe the input limits.

2.) Set lower range value	
Desired pressure for lower range value is present at device.	
↓	
Press the "Zero" key for at least 3 s.	
↓	
Does the LED on the electronic insert light up briefly?	
Yes	No
↓	↓

2.) Set lower range value	
Applied pressure for lower range value has been accepted.	Applied pressure for lower range value has not been accepted. Observe the input limits.

3.) Set upper range value	
Desired pressure for upper range value is present at device.	
↓	
Press the "Span" key for at least 3 s.	
↓	
Does the LED on the electronic insert light up briefly?	
Yes	No
↓	↓
Applied pressure for upper range value has been accepted.	Applied pressure for upper range value has not been accepted. Observe the input limits.

4.) Check settings	
Press "Zero" key briefly to display the lower range value.	
↓	
Press "Span" key briefly to display the upper range value.	
↓	
Press "Zero" and "Span" keys together briefly to display the calibration offset.	

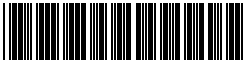

71316896

www.addresses.endress.com
