



Level



Pressure



Flow



Temperature



Liquid  
Analysis



Registration



Systems  
Components



Services



Solutions

Safety Instructions

# Liquiphant FailSafe FTL80, FTL81, FTL85

Control Drawing IS + XP



Document: XA00657F-B

Safety instructions for electrical apparatus for explosion-hazardous areas classified according to the Canadian Electrical Code (CEC) and National Electrical Code (NEC)



# Liquiphant FailSafe FTL80, FTL81, FTL85

## Table of contents

Associated documentation .....	4
Extended order code .....	4
Combined type of protection (Approval code, 8A) .....	4
Intrinsic safety (IS)	
CSA Installation drawing .....	6
Class I, Div. 1; Class II and Class III, Div. 1 .....	6
Flammable fluid seals .....	6
FM Installation drawing .....	7
Class I, Div. 1; Class II and Class III, Div. 1 .....	7
Process seals .....	7
Explosionproof (XP)	
CSA Installation drawing .....	8
Class I, Div. 1; Class II and Class III, Div. 1 .....	8
Flammable fluid seals .....	8
FM Installation drawing .....	9
Class I, Div. 1, DIP for Class II and Class III, Div. 1 .....	9
Process seals .....	9
Zone concept (X-marking) .....	10
Explosion protection with heat insulation .....	10
Temperature tables .....	11
Connection data .....	14

**Associated documentation**

This document is an integral part of the following Operating Instructions:  
BA01037F/00

The Operating Instructions pertaining to the device apply.

**Extended order code**

The extended order code is indicated on the nameplate, which is affixed to the device in such a way that it is clearly visible. Additional information about the nameplate is provided in the associated Operating Instructions.

**Structure of the extended order code**

FTL8x	- *****	+ A*B*C*D*E*F*G*..
Device type	Basic specifications	Optional specifications

\* = Placeholder

At this position, an option (number or letter) selected from the specification is displayed instead of the placeholders.

■ **Basic specifications**

The features that are absolutely essential for the device (mandatory features) are specified in the basic specifications. The number of positions depends on the number of features available. The selected option of a feature can consist of several positions.

■ **Optional specifications**

The optional specifications describe additional features for the device (optional features). The number of positions depends on the number of features available. The features have a 2-digit structure to aid identification (e.g. JA). The first digit (ID) stands for the feature group and consists of a number or a letter (e.g. J = test, certificate). The second digit constitutes the value that stands for the feature within the group (e.g. A = 3.1 material (wetted parts), inspection certificate).

More detailed information about the device is provided in the following tables. These tables describe the individual positions and IDs in the extended order code which are relevant to hazardous locations.

**Combined type of protection (Approval code, 8A)**

Devices with approval code "8A" are suitable for installation with explosion protection type of Intrinsic Safety or Explosionproof.

Before initial commissioning of the device, the type of protection used must be specified and indicated on the nameplate as outlined below. It is not permitted to change the type of protection after initial commissioning as this can jeopardize the explosion protection.

Using a striking tool, mark the explosion protection used, or void out the explosion protection that is not used.

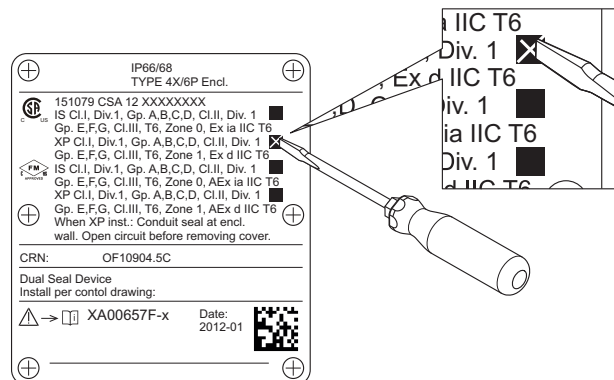

**Device type: FTL80, FTL81, FTL82**

## Basic specifications

Position	Selected option	Description
1, 2 Approval	FTL8x: 8A	FM/CSA IS + XP Cl. I, II, III, Div. 1, Gr. A-G, Cl. I, Zone 0, (A)Ex ia IIC T6 + Cl. I, Zone 1, (A)Ex d IIC T6
3 Electronics; Output	FTL8x: S	FEL85; 2-wire, 4-20 mA
4 Display; Operating	FTL8x: A	LED; switch
5 Housing	FTL8x: D E I	F13 Alu, IP66/68 NEPA Type 4X/6P Encl. T13 Alu, separate conn. compartment, IP66/68 NEPA Type 4X/6P Encl. F27 316L, IP66/68 NEPA Type 4X/6P Encl.
6 Electrical Connection	FTL8x: D E	Thread NPT1/2 Thread NPT3/4
7 Application	FTL80: A C D Y	Process max. 150 °C/302 °F, 64 bar/928 psi Process max. 230 °C/446 °F, 100 bar/1450 psi; incl. gas-tight feed through Process max. 280 °C/536 °F, 100 bar/1450 psi; incl. gas-tight feed through Process max. 300 °C/572 °F, 100 bar/1450 psi
	FTL81: A B C D Y	Process max. 150 °C/302 °F, 64 bar/928 psi Process max. 150 °C/302 °F, 100 bar/1450 psi Process max. 230 °C/446 °F, 100 bar/1450 psi; incl. gas-tight feed through Process max. 280 °C/536 °F, 100 bar/1450 psi; incl. gas-tight feed through Process max. 300 °C/572 °F, 100 bar/1450 psi
	FTL85: N P T	ECTFE, Process max. 120 °C/248 °F, 40 bar/580 psi PFA, Process max. 150 °C/302 °F, 40 bar/580 psi Enamel, Process max. 150 °C/302 °F, 25 bar/362 psi
9 Surface Refinement	FTL85: N P Q R T	Coating ECTFE Coating PFA (Edlon) Coating PFA (RubyRed) Coating PFA (conductive) Coating Enamel

## Optional specifications

ID	Selected option	Description
Mx Sensor Design	FTL8x: MP MR MS	Ambient temperature -50 °C/-58 °F Temperature separator Pressure tight feed through, incl. temperature separator
Nx Accessory Mounted	FTL8x: ND NE	Cover, housing F13 Alu, window Cover, housing T13 Alu, window

## Intrinsic safety (IS)

### CSA Installation drawing

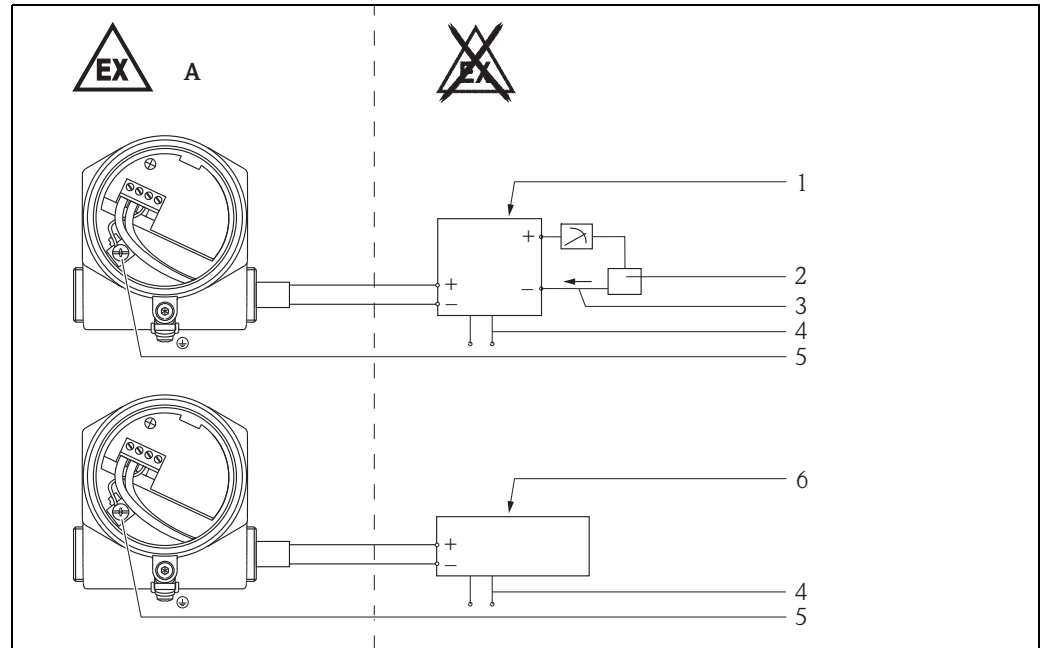

■ 1

**A** Class I, Div. 1, Groups A, B, C, D;  
Class II, Div. 1, Groups E, F, G;  
Class III  
Zone 0, Ex/AEx ia IIC T6

- 1 CSA-certified barrier/associated equipment  
2 External load  
3 4...20 mA  
4 Supply  
5 Ground stud  
6 CSA-certified associated Endress+Hauser transmitter  
Liquiphant FailSafe, Nivotester FTL825

Class I, Div. 1;  
Class II and Class III, Div. 1

**Intrinsically safe, Ex ia**

**Class I, Div. 1, Groups A-D, Class II, Div. 1, Groups E-G, Class III; Zone 0 Ex/AEx ia IIC T6**

### Hazardous locations installations

- Control room equipment may not use or generate over 250 V<sub>rms</sub>.
- Install as per CEC (Canadian Electrical Code) or NEC (National Electrical Code) (ANSI/NFPA70) and ISA RP 12.06.01.
- Warning: Substitution of components may impair intrinsic safety.
- Always follow the installation instructions provided by the intrinsic safety barrier manufacturer when installing this equipment. The configuration of the intrinsic safety barrier(s) must be CSA-certified.
- Use supply wires suitable for 20 K above the ambient temperature.

For entity installations:

- Use a CSA-certified intrinsic safety barrier or other associated equipment that satisfies the following conditions:  $V_{oc} \leq V_{max}$ ,  $I_{sc} \leq I_{max}$ ,  $C_a \geq C_i + C_{cable}$ ,  $L_a \geq L_i + L_{cable}$ . → 14, "Connection data" section.

For system installation:

- Use CSA-certified safety barriers or associated equipment.

### Flammable fluid seals

#### Single/Dual Seal per ANSI/ISA 12.27.01

Single seal device:

- Gas-tight conduit seal not required for FTL80, FTL81, FTL85: For version without gas-tight glass feed-through (Basic specification, Position 7 (Application) = A, B, N, P, T)

Dual seal device:

- Gas-tight conduit seal not required for FTL80, FTL81: For version with gas-tight glass feed-through (Basic specification, Position 7 (Application) = C, D, Y).

**FM Installation drawing**

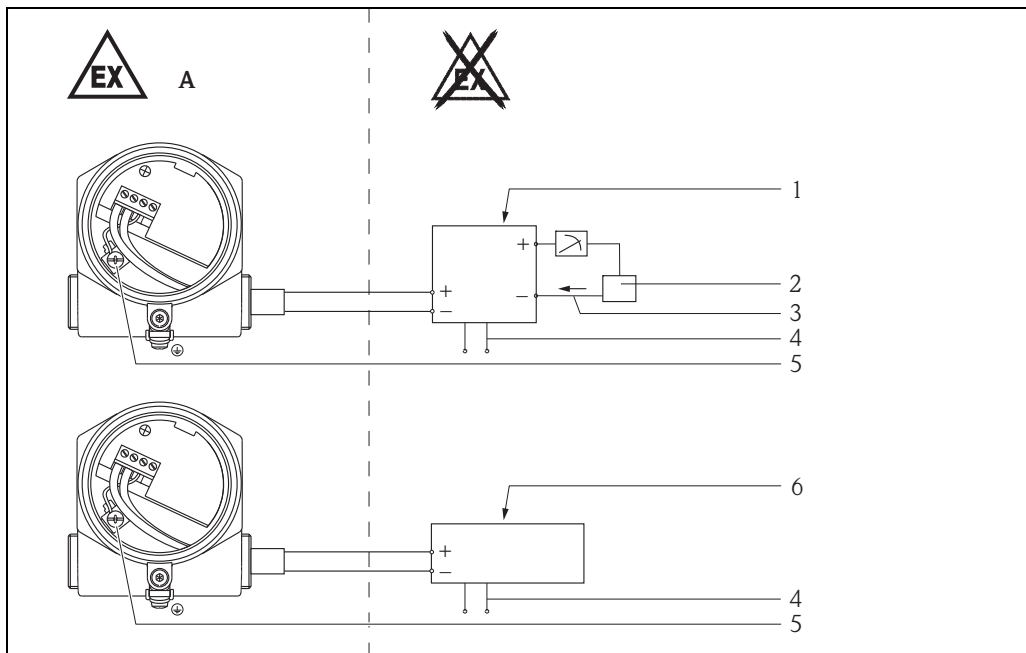

2

- A** Class I, Div. 1, Groups A, B, C, D;  
Class II, Div. 1, Groups E, F, G;  
Class III  
Zone 0, AEx/Ex ia IIC T6

- 1 FM-approved barrier/associated equipment
- 2 External load
- 3 4...20 mA
- 4 Supply
- 5 Ground stud
- 6 FM-approved associated Endress+Hauser transmitter  
Liquiphant FailSafe, Nivotester FTL825

**Class I, Div. 1;  
Class II and Class III, Div. 1**

**Intrinsically safe, AEx ia  
IS Class I, Div. 1, Groups A-D, Class II, Div. 1, Groups E-G, Class III; Zone 0 AEx/Ex ia IIC T6**

**Hazardous locations installations**

- Control room equipment may not use or generate over 250 V<sub>rms</sub>.
- Install as per NEC (National Electrical Code) (ANSI/NFPA70) and ISA RP 12.06.01.
- Warning: Substitution of components may impair intrinsic safety.
- Always follow the installation drawing provided by the intrinsic safety barrier manufacturer when installing this equipment. The configuration of the intrinsic safety barrier(s) must be FM-approved.
- Use supply wires suitable for 20 K above the ambient temperature.

For entity installations:

- Use a FM-approved intrinsic safety barrier or other associated equipment that satisfies the following conditions:  $V_{oc} \leq V_{max}$ ,  $I_{sc} \leq I_{max}$ ,  $C_a \geq C_1 + C_{cable}$ ,  $L_a \geq L_1 + L_{cable}$ . → 14, "Connection data" section.

For system installation:

- Use FM-approved safety barriers as follows:
  - (a) 28 V / 300 Ω + ground or
  - (b) 28 V / 300 Ω + 28 V / diode or
  - (c) 28 V / 300 Ω + 10 V / 50 W

**Process seals**

**Single/Dual Seal per ANSI/ISA 12.27.01**

Single seal device:

- Gas-tight conduit seal not required for FTL80, FTL81, FTL85: For version without gas-tight glass feed-through (Basic specification, Position 7 (Application) = A, B, N, P, T)

Dual seal device:

- Gas-tight conduit seal not required for FTL80, FTL81: For version with gas-tight glass feed-through (Basic specification, Position 7 (Application) = C, D, Y).

## Explosionproof (XP)

### CSA Installation drawing

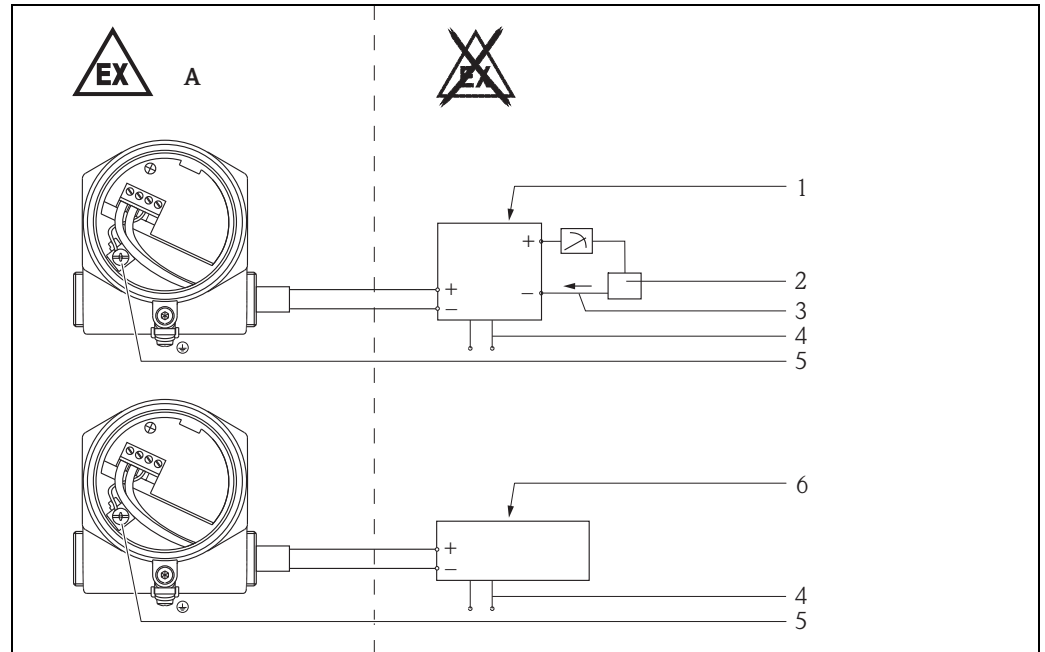

3

**A** Class I, Div. 1, Groups A, B, C, D;  
Class II, Div. 1, Groups E, F, G;  
Class III  
Zone 1, Ex/AEx d IIC T6

1 Power supply, 4...20 mA transmitter  
2 External load  
3 4...20 mA  
4 Supply  
5 Ground stud  
6 Endress+Hauser transmitter  
Liquiphant FailSafe, Nivotester FTL825

Class I, Div. 1;  
Class II and Class III, Div. 1

### Explosion proof

Class I, Div. 1, Groups A-D, Class II, Div. 1, Groups E-G, Class III; Zone 1 Ex/AEx d IIC T6

### Hazardous locations installations

- Control room equipment may not use or generate over 250 V<sub>rms</sub>.
- Install as per CEC (Canadian Electrical Code) or NEC (National Electrical Code) (ANSI/NFPA70) and ISA RP 12.06.01.
- Supply wires shall be installed in accordance with CEC or NEC.
- Install conduit seal at enclosure wall.
- Warning: Substitution of components may impair explosion protection.
- Use supply wires suitable for 20 K above the ambient temperature.

Terminal compartment:

- Warning: Keep cover tight when circuit is live unless the area is known to be non-hazardous.

### Flammable fluid seals

### Single/Dual Seal per ANSI/ISA 12.27.01

Single seal device:

- Gas-tight conduit seal not required for FTL80, FTL81, FTL85: For version without gas-tight glass feed-through (Basic specification, Position 7 (Application) = A, B, N, P, T)

Dual seal device:

- Gas-tight conduit seal not required for FTL80, FTL81: For version with gas-tight glass feed-through (Basic specification, Position 7 (Application) = C, D, Y).



**FM Installation drawing**

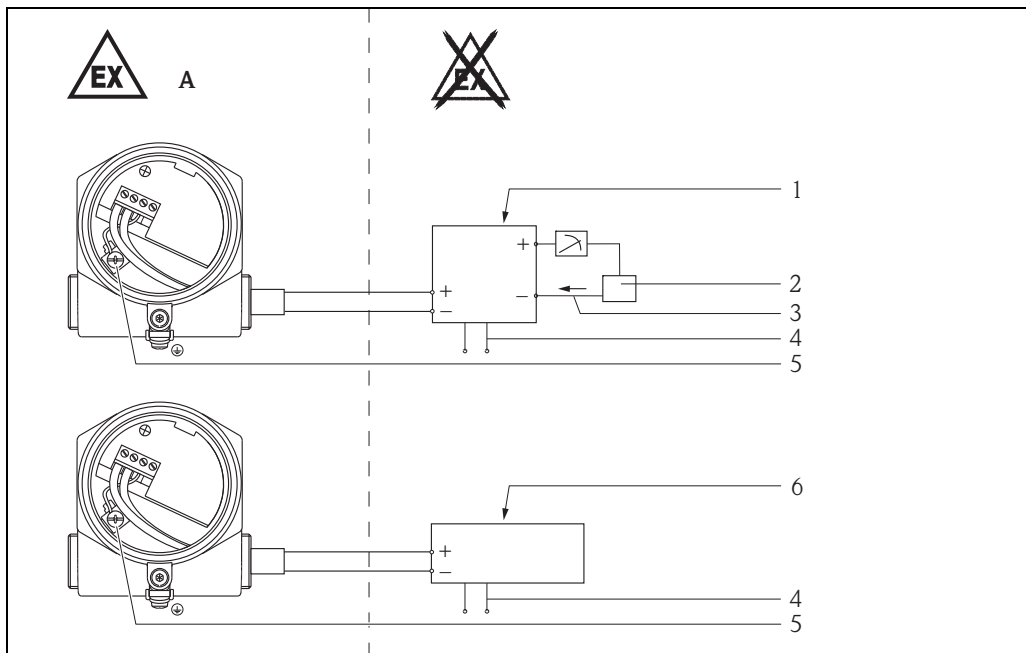

4

**A** Class I, Div. 1, Groups A, B, C, D;  
 Class II, Div. 1, Groups E, F, G;  
 Class III  
 Zone 1, AEx/Ex d IIC T6

- 1 Power supply, 4...20 mA transmitter
- 2 External load
- 3 4...20 mA
- 4 Supply
- 5 Ground stud
- 6 Endress+Hauser transmitter  
 Liquiphant FailSafe, Nivotester FTL825

**Class I, Div. 1, DIP for Class II and Class III, Div. 1**

**Explosion proof**

Device type FTL80, Basic specification, Position 5 (Housing) = D, E, I and  
 Device type FTL81, FTL85, Basic specification, Position 5 (Housing) = D, I:  
**XP Class I, Div. 1, Groups A, B, C, D, DIP for Class II, Div. 1, Groups E, F, G, Class III;  
 Zone 1 AEx/Ex d IIC T6**

Device type FTL81, FTL85, Basic specification, Position 5 (Housing) = E:  
**XP Class I, Div. 1, Groups B, C, D, DIP for Class II, Div. 1, Groups E, F, G, Class III;  
 Zone 1 AEx/Ex d IIC T6**

**Hazardous locations installations**

- Control room equipment may not use or generate over 250 V<sub>rms</sub>.
- Install as per NEC (National Electrical Code) (ANSI/NFPA70) and ISA RP 12.06.01.
- Supply wires shall be installed in accordance with NEC.
- Install conduit seal at enclosure wall.
- Warning: Substitution of components may impair explosion protection.
- Use supply wires suitable for 20 K above the ambient temperature.

Terminal compartment:

- Warning: Keep cover tight when circuit is live unless the area is known to be non-hazardous.

**Process seals**

**Single/Dual Seal per ANSI/ISA 12.27.01**

Single seal device:

- Gas-tight conduit seal not required for FTL80, FTL81, FTL85: For version without gas-tight glass feed-through (Basic specification, Position 7 (Application) = A, B, N, P, T)

Dual seal device:

- Gas-tight conduit seal not required for FTL80, FTL81: For version with gas-tight glass feed-through (Basic specification, Position 7 (Application) = C, D, Y).

**Zone concept (X-marking)****Electrostatic/impact sparks**

Gas group IIC

- If electrostatic charging of the probe can be avoided (e.g. through friction, cleaning, maintenance, strong medium flow), a probe coated with non-conductive material can be used.

Gas group IIB

- A probe coated with non-conductive material can be used.

Device type FTL85, Basic specification, Position 9 (Surface Refinement) = N, P, Q

- The probe can be electrostatically charged.
- Warning: Avoid electrostatic charging of the plastic surfaces, for plastic process connections or plastic coatings.
- Not suitable for dust application.

Basic specification, Position 5 (Housing) = D, E

- Avoid sparks caused by impact and friction.

**Explosion protection with heat insulation**

Device type FTL80, FTL81, Basic specification, Position 7 (Application) = C, D, Y

- While observing the "temperature derating", the device is suitable for process temperatures up to 300 °C (→ 13).
- When operating, ensure that you rule out contact between hot component surfaces and potentially explosive atmospheres beyond the limits of the corresponding temperature class (→ 12).  
Suitable measures: e.g. thermal insulation at container and/or pipes.
- The temperature of 85 °C specified at the reference point may not be exceeded.
- To protect the electronics, observe the specified ambient temperature at the electronics housing.

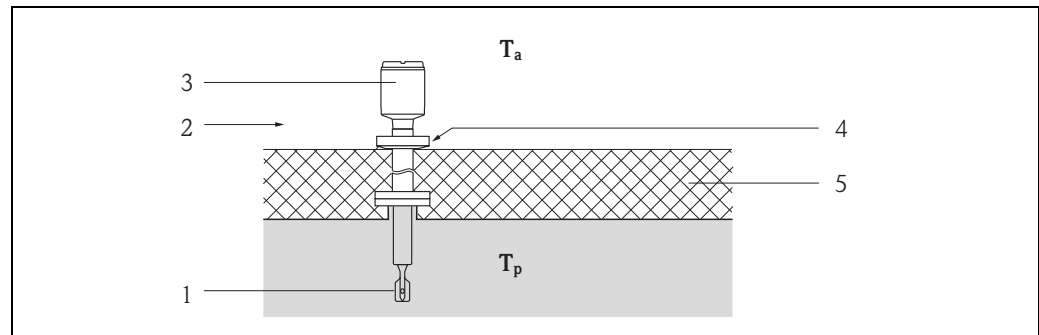

5

$T_a$  Ambient temperature

$T_p$  Process temperature

1 Sensor

2 Temperature class, e.g. T6

3 Housing

4 Reference point: max. +85 °C

5 E.g. thermal insulation

**Temperature tables**

Note!

Observe the permitted probe temperature range.

**Application in gas****Ambient temperature electronics****When used in Zone 0**

-20...+60 °C

**When used outside Zone 0**

-50...+70 °C

**Process temperature sensor****When used in Zone 0**

-20...+60 °C

Device type FTL80, FTL81, Basic specification, Position 7 (Application) = A, B, C, D, Y

**When used outside Zone 0**

-50...+150 °C (A, B)

-60...+230 °C (C)

-60...+280 °C (D)

-60...+300 °C (Y)

Device type FTL85, Basic specification, Position 7 (Application) = N, P, T

**When used outside Zone 0**

-50...+120 °C (N)

-50...+150 °C (P, T)

**Application in dust****Probe in Zone 20, electronics housing in Zone 21** $T = T_a + 10K$  $T_{500} = T_a + 30K$

The dependency of the ambient and process temperatures upon the temperature class:

Device type FTL80, FTL81, Basic specification, Position 7 (Application) = A, B

Temperature class	Process temperature $T_p$ (process): sensor	Ambient temperature $T_a$ (ambient): electronics
T6	-50...+ 85 °C	-50...+60 °C
T5	-50...+100 °C	-50...+70 °C
T4	-50...+135 °C	Additional temperature range for sensors with Optional specification Mx = MR, MS →  6
T3	-50...+150 °C	

Device type FTL80, FTL81, Basic specification, Position 7 (Application) = C, D, Y

Temperature class	Process temperature $T_p$ (process): sensor	Ambient temperature $T_a$ (ambient): electronics
T6	-60...+ 85 °C	-50...+60 °C
T5	-60...+100 °C	-50...+70 °C
T4	-60...+135 °C	For restrictions →  7
T3	-60...+200 °C	
T2	-60...+230 °C (C) -60...+280 °C (D) -60...+300 °C (Y)	

Device type FTL85, Basic specification, Position 7 (Application) = N, P, T

Temperature class	Process temperature $T_p$ (process): sensor	Ambient temperature $T_a$ (ambient): electronics
T6	-50...+ 85 °C	-50...+60 °C
T5	-50...+100 °C	-50...+70 °C
T4	-50...+120 °C (N)	Additional temperature range for sensors with Optional specification Mx = MR, MS →  6
T4	-50...+135 °C (P, T)	
T3	-50...+150 °C (P, T)	

Device type FTL80, FTL81, Basic specification, Position 7 (Application) = A, B  
 Device type FTL85, Basic specification, Position 7 (Application) = N, P, T

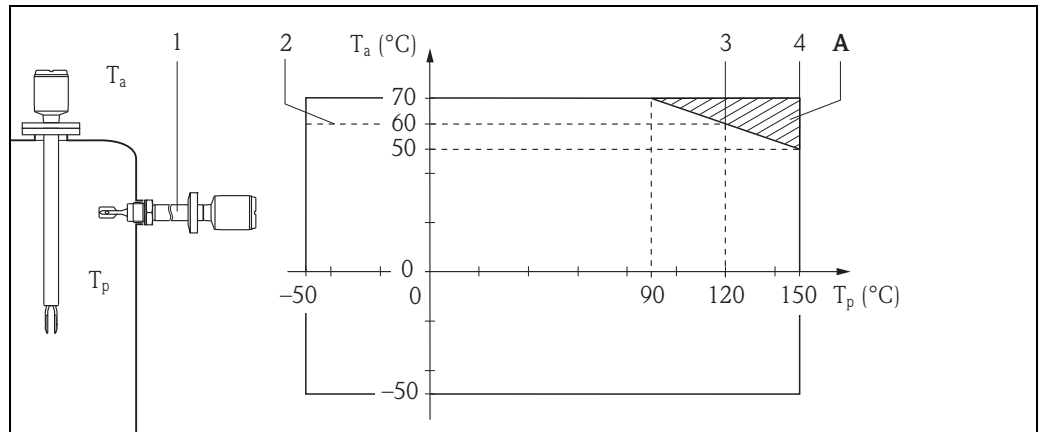

FTL8x\_04

6

- A** Additional temperature range for sensors with optional specifications  $Mx = MR, MS$
- 1 Temperature separator or pressure tight feed through
- 2  $T_a$  for  $T_6: -50...+60\text{ }^\circ\text{C}$
- 3 ECTFE
- 4 PFA, Enamel

Device type FTL80, FTL81, Basic specification, Position 7 (Application) = C, D, Y

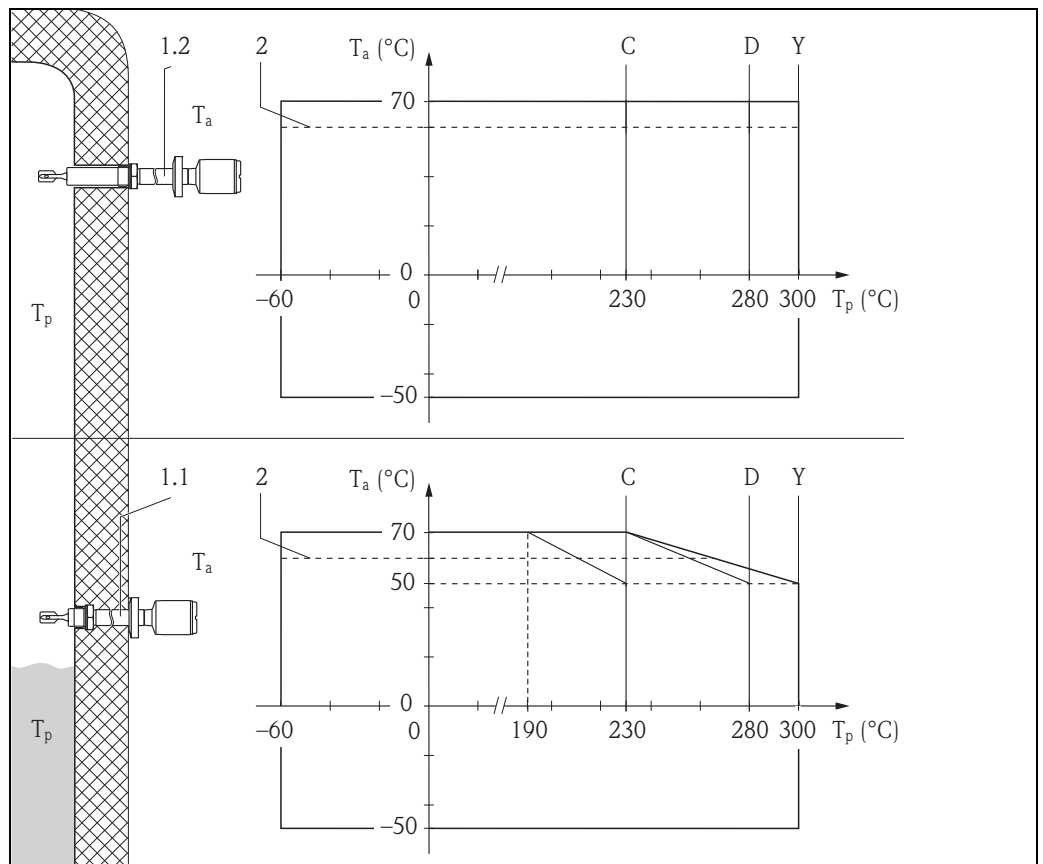

FTL8x\_06

7

- 1 Temperature separator:
  - 1.1 insulated
  - 1.2 free-standing
- 2  $T_a$  for  $T_6: -50...+60\text{ }^\circ\text{C}$

**Connection data**

Basic specification, Position 1, 2 (Approval) = 8A

**Intrinsically safe**

- Supply circuit with protection type: intrinsic safety Ex ia IIC.

Power supply:

- Barrier/associated equipment or
- CSA-certified or FM-approved associated apparatus or
- CSA-certified or FM-approved associated Endress+Hauser transmitter:  
Liquiphant FailSafe, Nivotester FailSafe



Note!

Only connect the device to terminals 1 and 2 or terminals 2 and 3, respectively.

**Terminal 1 (-)** Max. level safety

**Terminal 2 (+)**

**Terminal 3 (-)** Min. level safety

Power supply:

$$U_i \leq 30 \text{ V DC}$$

$$I_i \leq 170 \text{ mA}$$

$$P_i \leq 1 \text{ W}$$

effective inner inductance  $L_i = 0 \text{ mH}$

effective inner capacitance  $C_i \leq 16 \text{ nF}$

**Explosionproof**

Power supply:

- Barrier/associated equipment not required
- Endress+Hauser transmitter: Liquiphant FailSafe, Nivotester FailSafe



Note!

Only connect the device to terminals 1 and 2 or terminals 2 and 3, respectively.

**Terminal 1 (-)** Max. level safety

**Terminal 2 (+)**

**Terminal 3 (-)** Min. level safety

Power supply:

$$U_{in} = 30 \text{ V DC}$$

$$U_m = 250 \text{ V AC}$$

$$I_{Nom} = 4...20 \text{ mA}$$

$$P_{max} \leq 660 \text{ mW}$$



[www.endress.com/worldwide](http://www.endress.com/worldwide)

---

**Endress + Hauser**   
People for Process Automation

