

Hazardous location

Class I, Div. 1, Groups A, B, C, D

Class I, Zone 0, IIC
(see note 6)

Class I, Zone 1, IIC

Non hazardous location

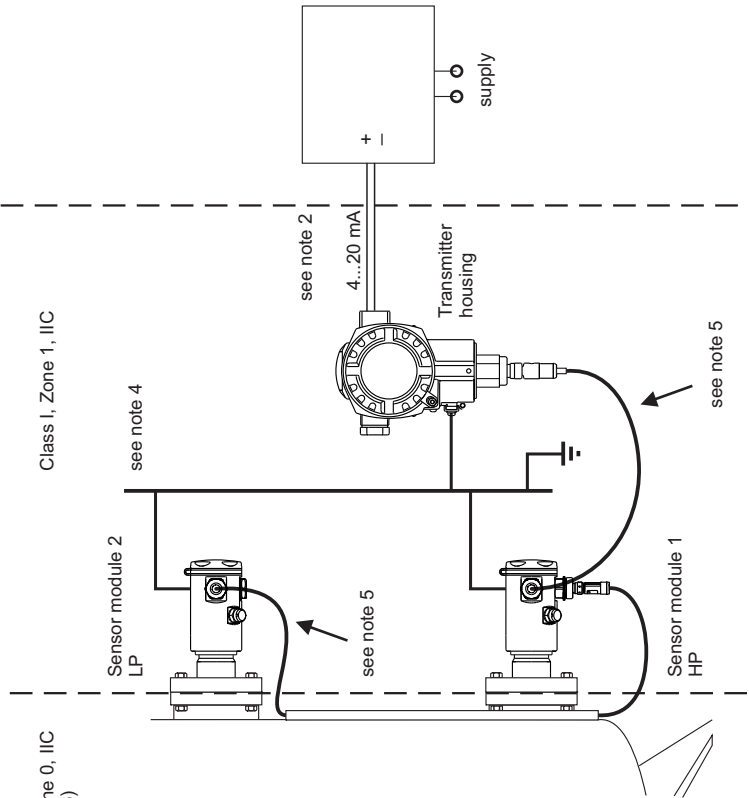

Table: Permissible ambient temperature and temperature code

Temperature code	Permissible ambient temperature, electronic compartment
T6	-40 °C...40 °C
T4	-40 °C...70 °C

Suitable for Cl. I, Div. 1, Groups A, B, C, D, Class I, Zone 0 and Zone 1, IIC
AEx/Ex d [Ia] IIC T6

Hazardous Location Installation

1. Install per Canadian Electrical Code, Part I or National Electrical Code (ANSI/NFPA70) as applicable
 - max. supply voltage 45 VDC
 - max. ambient temperature: see table
2. Explosionproof conduit seals must be installed within 18 inches of the transmitter housing.
3. Warning: Open circuit before removing cover.
Avertissement : Ouvrir le circuit avant d'enlever le couvercle.
4. Transmitter housing and sensor modules must have the same ground potential (e.g. transmitter housing and sensor modules all mounted to the same metal structure). If potential equalisation can not be achieved by the installation, the devices must be interconnected with a suitable bonding conductor using the external ground connections.
5. Transmitter provides Intrinsically Safe (type of protection 'ia') circuits for connection to and between HP Sensor module 1 and LP Sensor module 2.
6. For Zone classified areas, transmitter housing must be installed in a Class I, Zone 1 hazardous location.
The intrinsically safe sensor modules can be installed in a Class I, Zone 0 (process side) or Zone 1 hazardous location.
7. Sensor modules may only be connected to the transmitter and interconnected to each other. Any further connections are not allowed.

The devices are CSA certified as Single Seal per ANSI/ISA 12.27.01 as tabulated below; therefore installation of external secondary seals is not required.

Single Seal	Model	Limited to:	
		MWP*	Process temperature**
	FMD72	40 bar (580 psi)	-40 °C...+100 °C

* Limitations of the Maximum Working Pressure (MWP) are marked on the nameplate and must be considered!

** Limitations of the process temperature range depending on the used version are specified in the applicable technical information of the manufacturer and must be considered!

