



Level



Pressure



Flow



Temperature



Liquid  
Analysis



Registration



Systems  
Components



Services



Solutions

Operating Instructions

# Proline Promag 23 HART

Electromagnetic Flow Measuring System  
Two-wire technology

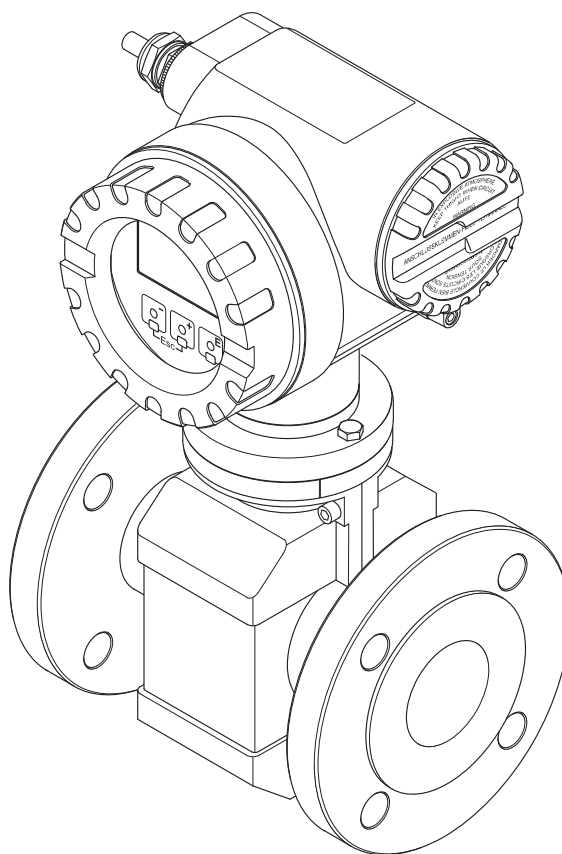

BA00045D/06/EN/13.10  
71111263

Valid as of version  
V 2.02.XX (device software)

**Endress+Hauser**

People for Process Automation



## Table of contents

<b>1</b>	<b>Safety instructions</b>	<b>5</b>	<b>5</b>	<b>Operation</b>	<b>32</b>
1.1	Designated use	5	5.1	Display and operating elements	32
1.2	Installation, commissioning and operation	5	5.1.1	Display (operating mode)	33
1.3	Operational safety	5	5.1.2	Additional display functions	33
1.4	Return	6	5.1.3	Icons	33
1.5	Notes on safety conventions and icons	6	5.2	Brief Operating Instructions for the function matrix	34
<b>2</b>	<b>Identification</b>	<b>7</b>	5.2.1	General notes	35
2.1	Device designation	7	5.2.2	Enabling the programming mode	35
2.1.1	Nameplate of the transmitter	7	5.2.3	Disabling the programming mode	35
2.1.2	Nameplate of the sensor	8	5.3	Error messages	36
2.2	Certificates and approvals	9	5.3.1	Type of error	36
2.3	Registered trademarks	9	5.3.2	Error message type	36
<b>3</b>	<b>Installation</b>	<b>10</b>	5.3.3	Confirming error messages	37
3.1	Incoming acceptance, transport and storage	10	5.4	Communication	37
3.1.1	Incoming acceptance	10	5.4.1	Operating options	38
3.1.2	Transport	10	5.4.2	Current device description files	38
3.1.3	Storage	11	5.4.3	Universal/Common practice HART commands	39
3.2	Installation conditions	12	5.4.4	Switching HART write protection on and off	41
3.2.1	Dimensions	12	<b>6</b>	<b>Commissioning</b>	<b>42</b>
3.2.2	Mounting location	12	6.1	Function check	42
3.2.3	Orientation	14	6.2	Switching on the measuring device	42
3.2.4	Inlet and outlet runs	15	6.3	Data backup/transmission	43
3.2.5	Vibrations	15	6.4	Adjustment	44
3.2.6	Adapters	16	6.4.1	Empty-pipe/Full-pipe adjustment	44
3.2.7	Nominal diameter and flow rate	17	6.5	Data storage devices	45
3.3	Installation	18	6.5.1	HistoROM/S-DAT (sensor DAT)	45
3.3.1	Installing the Promag P sensor	18	6.5.2	HistoROM/T-DAT (transmitter DAT)	45
3.3.2	Installing the Promag H sensor	22	<b>7</b>	<b>Maintenance</b>	<b>46</b>
3.3.3	Turning the transmitter housing	25	7.1	Exterior cleaning	46
3.3.4	Turning the local display	25	7.2	Seals	46
3.4	Post-installation check	26	<b>8</b>	<b>Accessories</b>	<b>47</b>
<b>4</b>	<b>Wiring</b>	<b>27</b>	8.1	Device-specific accessories	47
4.1	Connecting the measuring unit	27	8.2	Accessories specific to measuring principle	47
4.1.1	Connecting the transmitter	27	8.3	Communication-specific accessories	48
4.1.2	Terminal assignment	28	8.4	Service-specific accessories	49
4.1.3	HART connection	28	<b>9</b>	<b>Troubleshooting</b>	<b>50</b>
4.2	Potential equalization	29	9.1	Troubleshooting instructions	50
4.2.1	Potential equalization, Promag P	29	9.2	System error messages	51
4.2.2	Potential equalization, Promag H	29	9.3	Process error messages	53
4.2.3	Connection examples for potential equalization	29	9.4	Process errors without messages	54
4.3	Degree of protection	31	9.5	Response of outputs to errors	55
4.4	Post-connection check	31	9.6	Spare parts	56
			9.6.1	Removing and installing electronics boards	57
			9.7	Return	59
			9.8	Disposal	59
			9.9	Software history	59

<b>10</b>	<b>Technical data</b>	<b>60</b>
10.1	Technical data at a glance	60
10.1.1	Application	60
10.1.2	Function and system design	60
10.1.3	Input	60
10.1.4	Output	60
10.1.5	Power supply	62
10.1.6	Performance characteristics	63
10.1.7	Operating conditions: Installation	63
10.1.8	Operating conditions: Environment	64
10.1.9	Operating conditions: Process	65
10.1.10	Mechanical construction	68
10.1.11	Human interface	71
10.1.12	Certificates and approvals	72
10.1.13	Ordering information	73
10.1.14	Accessories	73
10.1.15	Documentation	73
	<b>Index</b>	<b>74</b>

# 1 Safety instructions

## 1.1 Designated use

The measuring device described in this Operating Manual is to be used only for measuring the flow rate of conductive fluids in closed pipes.

Fluids with a minimum conductivity of 50  $\mu\text{S}/\text{cm}$  can be metered.

Examples:

- Acids, alkalis, paints
- Water
- Beverages, e.g. juice, beer, wine, etc.

Resulting from incorrect use or from use other than that designated the operational safety of the measuring devices can be suspended. The manufacturer accepts no liability for damages being produced from this.



## 1.2 Installation, commissioning and operation

Note the following points:

- Installation, connection to the electricity supply, commissioning and maintenance of the device must be carried out by trained, qualified specialists authorized to perform such work by the facility's owner-operator. The specialist must have read and understood these Operating Instructions and must follow the instructions they contain.
- The device must be operated only by persons authorized and trained by the system operator. Strict compliance with the instructions in the Operating Instructions is mandatory.
- Endress+Hauser is willing to assist in clarifying the chemical resistance properties of parts wetted by special fluids, including fluids used for cleaning. However, small changes in temperature, concentration or the degree of contamination in the process can result in changes to the chemical resistance properties. For this reason, Endress+Hauser does not accept any responsibility with regard to the corrosion resistance of materials wetted by fluids in a specific application. The user is responsible for the choice of wetted materials with regard to their in-process resistance to corrosion.
- If welding work is performed on the piping system, do not ground the welding appliance through the flowmeter.
- The installer must ensure that the measuring system is correctly wired in accordance with the wiring diagrams.
- Invariably, local regulations governing the opening and repair of electrical devices apply.

## 1.3 Operational safety

Note the following points:

- Measuring systems for use in hazardous environments are accompanied by separate "Ex documentation", which is an integral part of these Operating Instructions. Strict compliance with the installation instructions and ratings as stated in this supplementary documentation is mandatory. Depending on the approval and certification agency, the relevant symbol is depicted on the front page of the supplementary documentation on Ex ratings (e.g.  Europe,  USA,  Canada).
- The measuring device meets the general safety requirements according to EN 61010-1 and the EMC requirements according to IEC/EN 61326 in addition to the NAMUR recommendations NE 21 and NE 43.
- Depending on the application, the seals of the process connections of the Promag H sensor require periodic replacement.
- When hot fluid passes through the measuring tube, the surface temperature of the housing increases. In the case of the sensor, in particular, users should expect temperatures that can be close to the fluid temperature. If the temperature of the fluid is high, implement sufficient measures to prevent burning or scalding.

- The manufacturer reserves the right to modify technical data without prior notice. Your Endress+Hauser distributor will supply you with current information and updates to these Operating Instructions.

## 1.4 Return

- Do not return a measuring device if you are not absolutely certain that all traces of hazardous substances have been removed, e.g. substances which have penetrated crevices or diffused through plastic.
- Costs incurred for waste disposal and injury (burns, etc.) due to inadequate cleaning will be charged to the owner-operator.

## 1.5 Notes on safety conventions and icons

The devices are designed and tested to meet state-of-the-art safety requirements, and have left the factory in a condition in which they are safe to operate. The devices comply with the applicable standards and regulations in accordance with EN 61010 -1 "Protection Measures for Electrical Equipment for Measurement, Control, Regulation and Laboratory Procedures". The devices can, however, be a source of danger if used incorrectly or for other than the designated use. For this reason, always pay particular attention to the safety instructions indicated in these Operating Instructions by the following icons:



Warning!

"Warning" indicates an action or procedure which, if not performed correctly, can result in personal injury or a safety hazard. Comply strictly with the instructions and proceed with care.



Caution!

"Caution" indicates an action or procedure which, if not performed correctly, can result in incorrect operation or destruction of the device. Comply strictly with the instructions.



Note!

"Note" indicates an action or procedure which, if not performed correctly, can have an indirect effect on operation or trigger an unexpected response on the part of the device.

## 2 Identification

### 2.1 Device designation

The flow measuring system consists of the following components:

- Promag 23 transmitter
- Promag P, Promag H sensor

Transmitter and sensor form a single mechanical unit.

#### 2.1.1 Nameplate of the transmitter

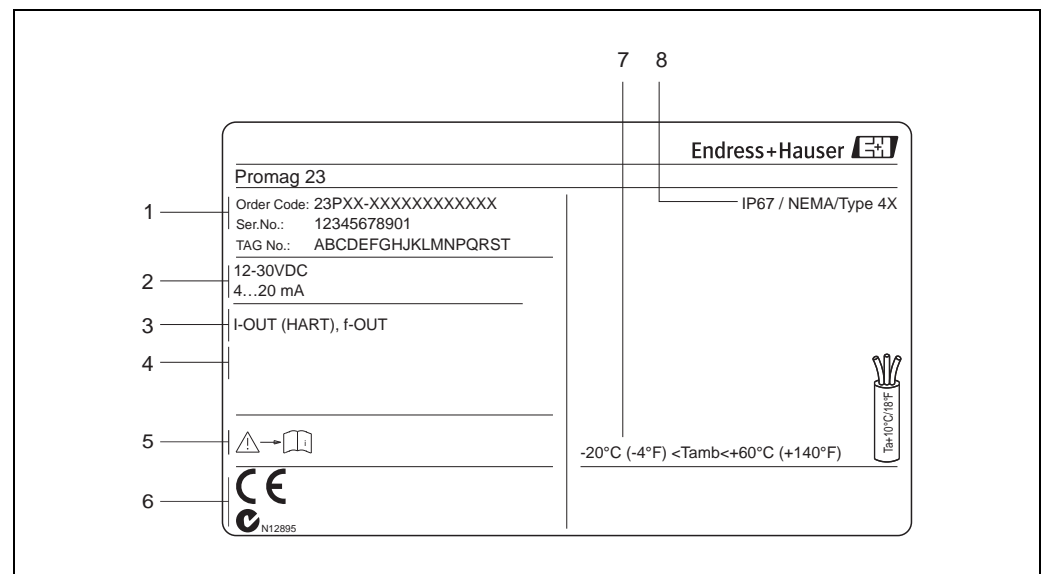

Fig. 1: Nameplate specifications for the "Promag 23" transmitter (example)

- 1 Order code/serial number: see the specifications on the order confirmation for the meanings of the individual letters and digits
- 2 Power supply, frequency  
power consumption
- 3 Available outputs:
  - I-OUT (HART): with current output (HART)
  - f-OUT: with pulse/frequency output
- 4 Reserved for additional information on special products
- 5 Please comply with the Operating Instructions
- 6 Reserved for additional information on device version (approvals, certificates)
- 7 Permitted ambient temperature range
- 8 Degree of protection

### 2.1.2 Nameplate of the sensor

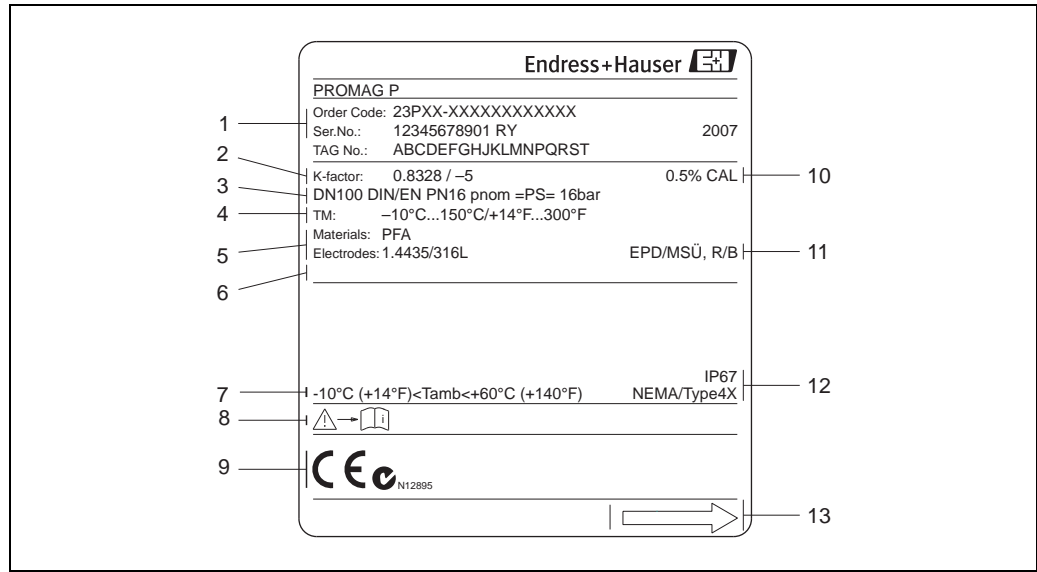

Fig. 2: Nameplate specifications for the "Promag P" sensor (example)

- 1 Order code/serial number: see the specifications on the order confirmation for the meanings of the individual letters and digits
- 2 Calibration factor with zero point
- 3 Nominal diameter/nominal pressure
- 4 Medium temperature range
- 5 Materials: lining/measuring electrodes
- 6 Reserved for additional information on special products
- 7 Permitted ambient temperature range
- 8 Please comply with the Operating Instructions
- 9 Reserved for additional information on device version (approvals, certificates)
- 10 Calibration tolerance
- 11 Additional information
  - EPD: with empty pipe detection electrode
  - R/B: with reference electrode
- 12 Degree of protection
- 13 Flow direction



## 2.2 Certificates and approvals

The devices are designed and tested to meet state-of-the-art safety requirements in accordance with sound engineering practice. They have left the factory in a condition in which they are safe to operate.

The devices comply with the standards EN 61010 -1 "Protection Measures for Electrical Equipment for Measurement, Control, Regulation and Laboratory Procedures" and with the EMC requirements of IEC/EN 61326.

The measuring system described in these Operating Instructions therefore complies with the legal requirements of the EU Directives. Endress+Hauser confirms this by affixing the CE mark to it and by issuing the CE Declaration of Conformity.

The measuring system is in conformity with the EMC requirements of the "Australian Communications and Media Authority (ACMA)".

## 2.3 Registered trademarks

KALREZ® and VITON®

Registered trademarks of E.I. Du Pont de Nemours & Co., Wilmington, USA

TRI-CLAMP®

Registered trademark of Ladish & Co., Inc., Kenosha, USA

HART®

Registered trademark of HART Communication Foundation, Austin, USA

HistoROM™, S-DAT®, T-DAT™, Field Xpert™, FieldCare®, Fieldcheck®, Applicator®

Registered or registration-pending trademarks of Endress+Hauser Flowtec AG, Reinach, CH

## 3 Installation

### 3.1 Incoming acceptance, transport and storage

#### 3.1.1 Incoming acceptance

On receipt of the goods, check the following points:

- Check the packaging and the contents for damage.
- Check the shipment, make sure nothing is missing and that the scope of supply matches your order.

#### 3.1.2 Transport

The following instructions apply to unpacking and to transporting the device to its final location:

- Transport the devices in the containers in which they are delivered.
- Do not remove the protection plates or caps on the process connections until you are ready to install the device. This is particularly important in the case of sensors with PTFE linings.

#### Special notes on flanged devices



Caution!

- The wooden covers mounted on the flanges before the device leaves the factory protect the linings on the flanges during storage and transportation. Do not remove these protection plates until *immediately before* the device is installed in the pipe.
- Do not lift flanged devices by the transmitter housing.

Use webbing slings slung round the two process connections. Do not use chains, as they could damage the housing.



Warning!

Risk of injury if the measuring device slips. The center of gravity of the assembled measuring device might be higher than the points around which the slings are slung.

At all times, therefore, make sure that the device does not unexpectedly turn around its axis or slip.

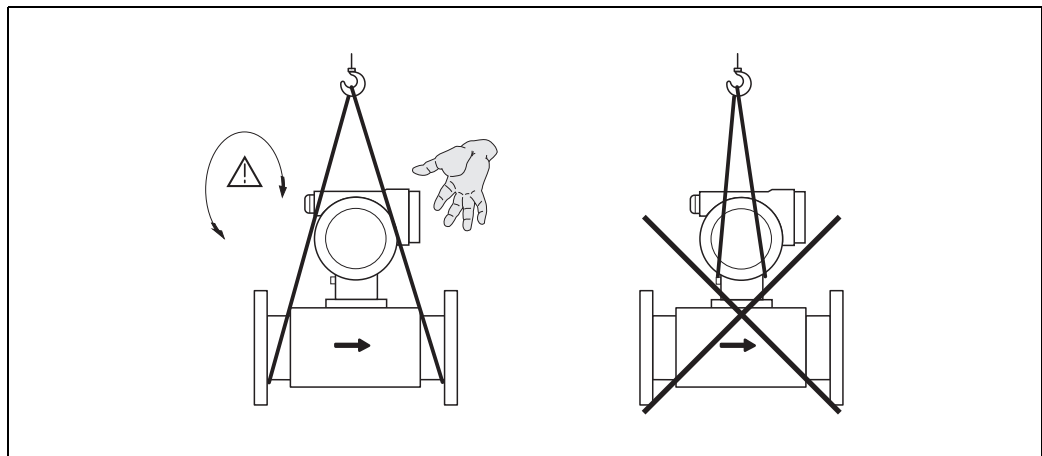

Fig. 3: Transporting sensors

A0009746

### 3.1.3 Storage

Note the following points:

- Pack the measuring device in such a way as to protect it reliably against impact for storage (and transportation). The original packaging provides optimum protection.
- The storage temperature corresponds to the operating temperature range of the measuring transmitter and the appropriate measuring sensors → [64](#).
- Do not remove the protection plates or caps on the process connections until you are ready to install the device. This is particularly important in the case of sensors with PTFE linings.
- The measuring device must be protected against direct sunlight during storage in order to avoid unacceptably high surface temperatures.
- Choose a storage location where moisture does not collect in the measuring device. This will help prevent fungus and bacteria infestation which can damage the lining.

## 3.2 Installation conditions

### 3.2.1 Dimensions

The dimensions and installation lengths of the sensor and transmitter can be found in the "Technical Information" for the device in question. This document can be downloaded as a PDF file from [www.endress.com](http://www.endress.com). A list of the "Technical Information" documents available is provided in the "Documentation" section on → 73.

### 3.2.2 Mounting location

The accumulation of air or gas bubbles in the measuring tube could result in an increase in measuring errors.

**Avoid** the following locations:

- At the highest point of a pipeline. Risk of air accumulating!
- Directly upstream from a free pipe outlet in a vertical pipeline.

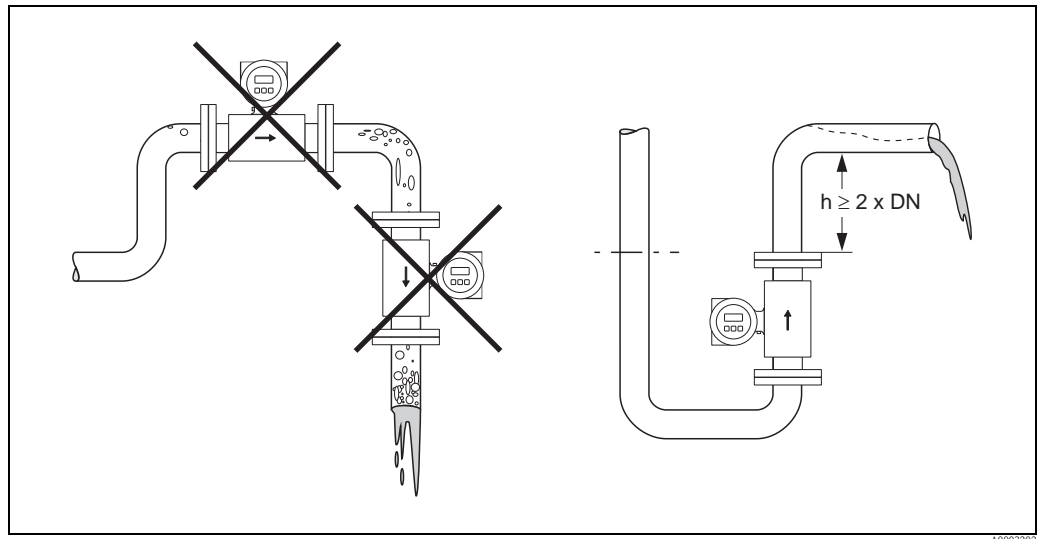

Fig. 4: Mounting location

### Installing pumps

Do not install the sensor on the intake side of a pump. This precaution is to avoid low pressure and the consequent risk of damage to the lining of the measuring tube. Information on the lining's resistance to partial vacuum → 66.

It might be necessary to install pulse dampers in systems incorporating reciprocating, diaphragm or peristaltic pumps. Information on the measuring system's resistance to vibration and shock → 64.

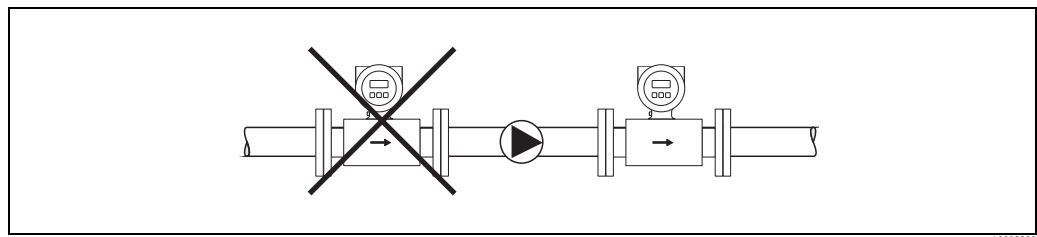

Fig. 5: Installing pumps

### Partially filled pipes

Partially filled pipes with gradients necessitate a drain-type configuration. The Empty Pipe Detection function offers additional protection by detecting empty or partially filled pipes → 44.



#### Caution!

Risk of solids accumulating. Do not install the sensor at the lowest point in the drain. It is advisable to install a cleaning valve.

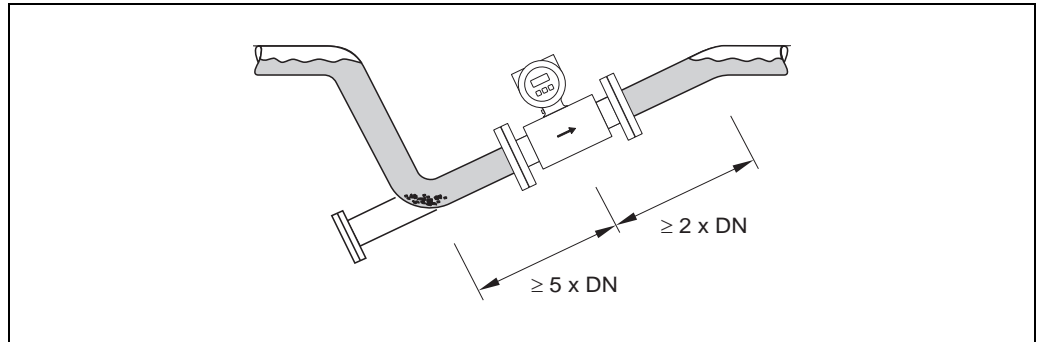

Fig. 6: Installation in partially filled pipe

### Down pipes

Install a siphon or a vent valve downstream of the sensor in down pipes longer than 5 m (16,4 ft). This precaution is to avoid low pressure and the consequent risk of damage to the lining of the measuring tube. This measure also prevents the system losing prime, which could cause air inclusions.

Information on the lining's resistance to partial vacuum → 66

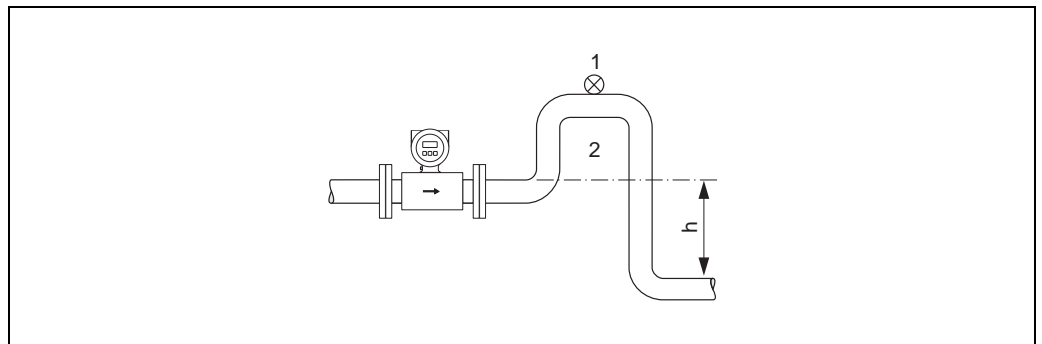

Fig. 7: Measures for installation in a down pipe

- 1 Vent valve
- 2 Siphon
- h Length of down pipe

### 3.2.3 Orientation

An optimum orientation position helps avoid gas and air accumulations and deposits in the measuring tube. However, Promag offers the additional Empty Pipe Detection (EPD) function to ensure the detection of partially filled measuring tubes, e.g. in the case of degassing fluids or varying process pressure → 44.

#### Vertical orientation

A vertical orientation is ideal for self-emptying piping systems and when using empty pipe detection.

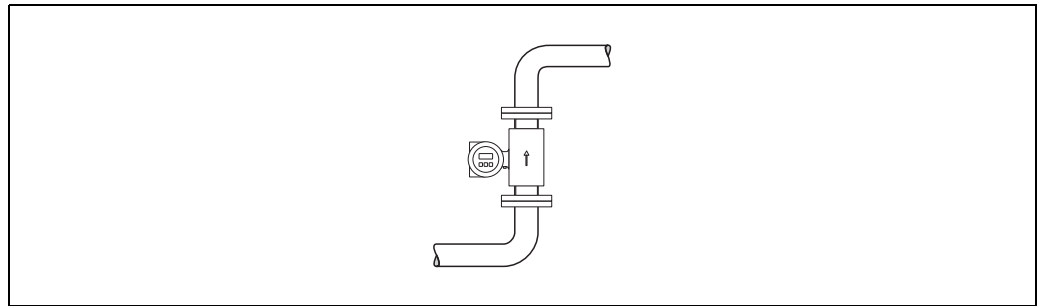

Fig. 8: Vertical orientation

#### Horizontal orientation

The measuring electrode plane should be horizontal. This prevents brief insulation of the two electrodes by entrained air bubbles.



Caution!

Empty Pipe Detection functions correctly with the measuring device installed horizontally only when the transmitter housing is facing upward (→ 9). Otherwise there is no guarantee that Empty Pipe Detection will respond if the measuring tube is only partially filled or empty.

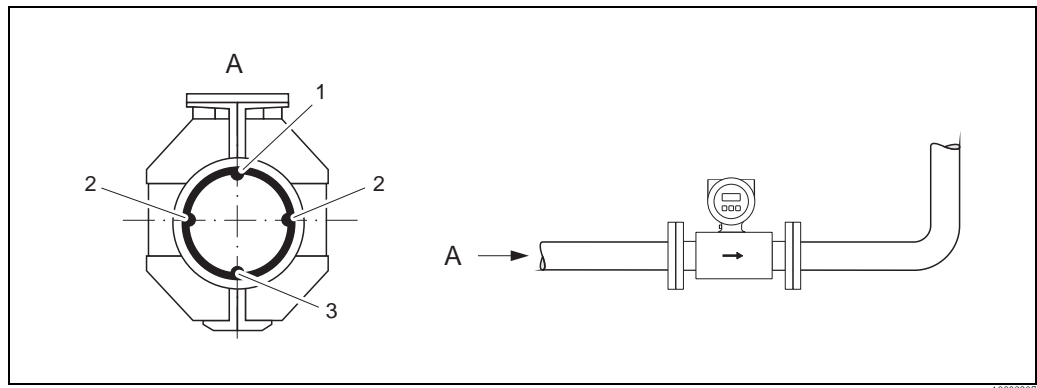

Fig. 9: Horizontal orientation

- 1 EPD electrode for empty pipe detection (not in Promag H (DN 2 to 15 / 1/12 to 1/2"))
- 2 Measuring electrodes for signal detection
- 3 Reference electrodes for potential equalization (not in Promag H)

### 3.2.4 Inlet and outlet runs

If possible, install the sensor in a location upstream of fittings such as valves, T-pieces, elbows, etc. Compliance with the following requirements for the inlet and outlet runs is necessary in order to ensure measuring accuracy.

- Inlet run  $\geq 5 \times \text{DN}$
- Outlet run  $\geq 2 \times \text{DN}$

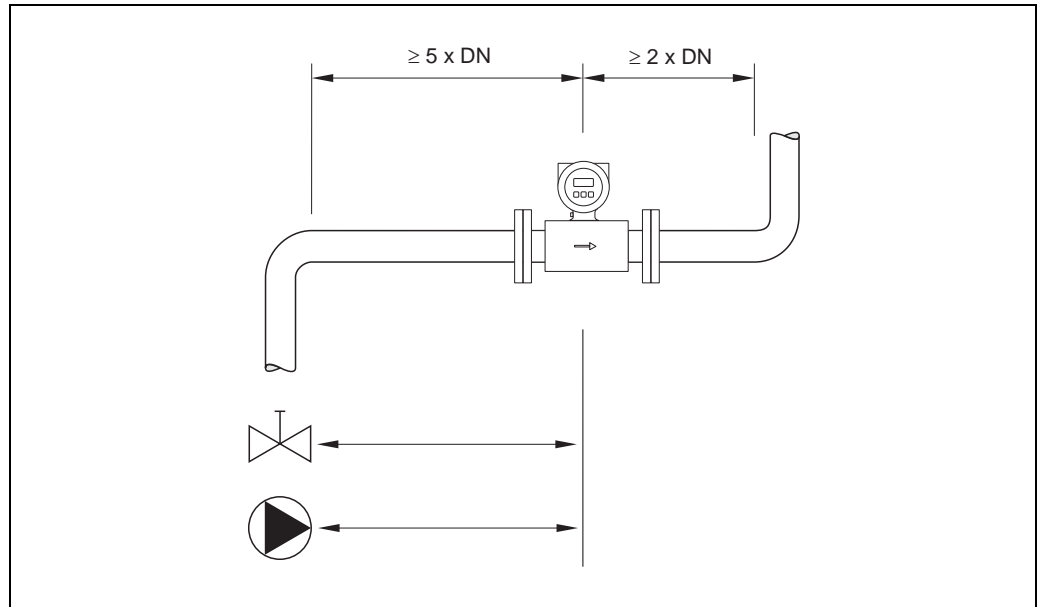

Fig. 10: Inlet and outlet runs

### 3.2.5 Vibrations

Secure and fix both the piping and the sensor if the vibrations are severe.



Caution!

Information on the permitted resistance to vibration and shock → 64.

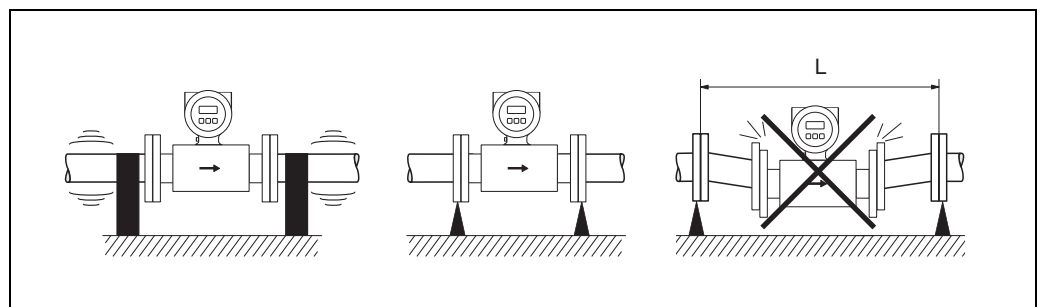

Fig. 11: Measures to prevent vibration of the measuring device ( $L > 10 \text{ m}$  (32.8 ft))

### 3.2.6 Adapters

Suitable adapters to DIN EN 545 (double-flange reducers) can be used to install the sensor in larger-diameter pipes. The resultant increase in the rate of flow improves measuring accuracy with very slow-moving fluids.

The nomogram shown here can be used to calculate the pressure loss caused by cross-section reduction.



Note!

The nomogram only applies to liquids of viscosity similar to water.

1. Calculate the ratio of the diameters  $d/D$ .
2. From the nomogram, read off the pressure loss as a function of fluid velocity (*downstream* from the reduction) and the  $d/D$  ratio.

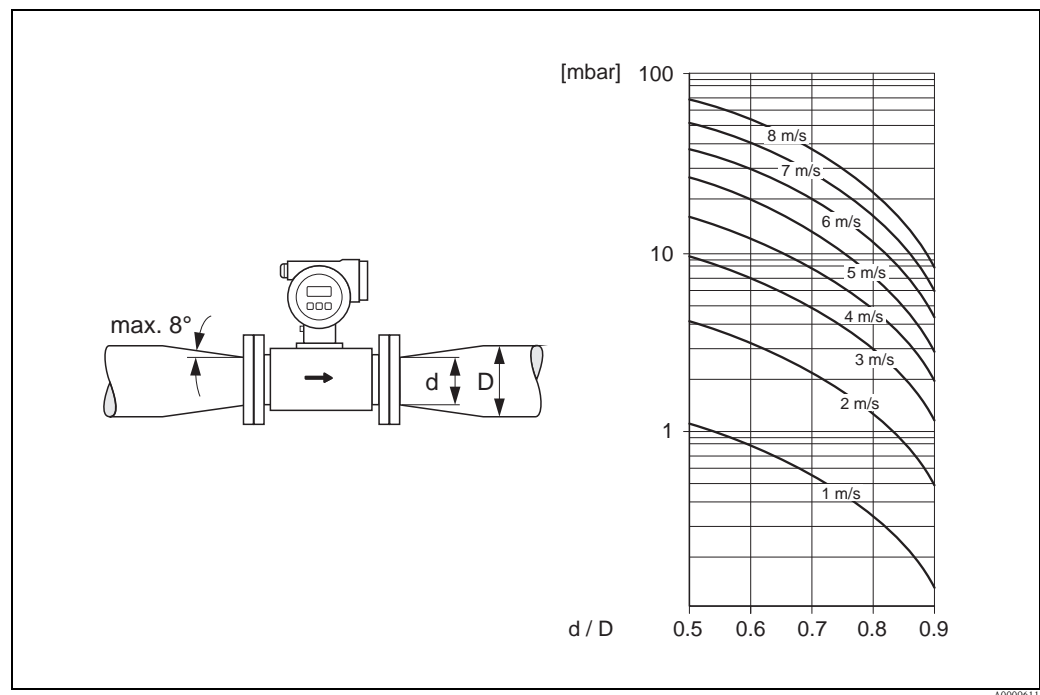

Fig. 12: Pressure loss due to adapters

A0009011



### 3.2.7 Nominal diameter and flow rate

The diameter of the pipe and the flow rate determine the nominal diameter of the sensor. The optimum velocity of flow is between 2 and 3 m/s (6.5 to 9.8 ft/s).

The velocity of flow ( $v$ ), moreover, has to be matched to the physical properties of the fluid:

- $v < 2$  m/s ( $v < 6.5$  ft/s): for abrasive fluids
- $v > 2$  m/s ( $v > 6.5$  ft/s): for fluids producing buildup



Note!

Flow velocity can be increased, if necessary, by reducing the nominal diameter of the sensor  
→ 16.

#### Recommended flow (SI units)

Nominal diameter [mm]	Promag P	Promag H
	Min./max. full scale value ( $v \approx 0.3$ or $10$ m/s) in [dm <sup>3</sup> /min]	
2	–	0.06 to 1.8
4	–	0.25 to 7
8	–	1 to 30
15	–	4 to 100
25	9 to 300	9 to 300
32	15 to 500	–
40	25 to 700	25 to 700
50	35 to 1100	35 to 1100
65	60 to 2000	60 to 2000
80	90 to 3000	90 to 3000
100	145 to 4700	145 to 4700
125	220 to 7500	–
[mm]	Min./max. full scale value ( $v \approx 0.3$ or $10$ m/s) in [m <sup>3</sup> /h]	
150	20 to 600	–
200	35 to 1100	–

#### Recommended flow (US units)

Nominal diameter [inch]	Promag P	Promag H
	Min./max. full scale value ( $v \approx 0.3$ or $10$ m/s) in [gal/min]	
1/12"	–	0.015 to 0.5
5/32"	–	0.07 to 2
5/16"	–	0.25 to 8
1/2"	–	1.0 to 27
1"	2.5 to 80	2.5 to 80
1 1/4"	4 to 130	–
1 1/2"	7 to 190	7 to 190
2"	10 to 300	10 to 300
2 1/2"	16 to 500	16 to 500
3"	24 to 800	24 to 800
4"	40 to 1250	40 to 1250
5"	60 to 1950	–
6"	90 to 2650	–
8"	155 to 4850	–

## 3.3 Installation

### 3.3.1 Installing the Promag P sensor



#### Caution!

- The protective covers mounted on the two sensor flanges guard the PTFE lining, which is turned over the flanges. Consequently, do not remove these protection plates **until immediately before** the sensor is installed in the pipe.
- Protection plates must remain in place while the device is in storage.
- Make sure that the lining is not damaged or removed from the flanges.



#### Note!

Bolts, nuts, seals, etc. are not included in the scope of supply and must be supplied by the customer.

The sensor is designed for installation between the two piping flanges:

- It is essential that you observe the necessary screw tightening torques on → 20.
- If grounding disks are used, follow the mounting instructions which will be enclosed with the shipment.

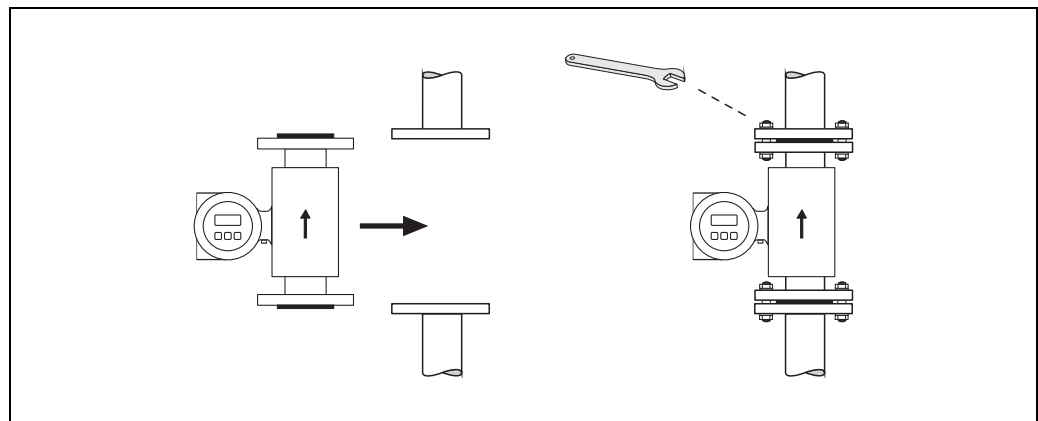

Fig. 13: Installing the Promag P sensor

#### Seals

Comply with the following instructions when installing seals:

- PFA or PTFE lining → seals are **not** required.
- Only use seals that comply with DIN EN 1514-1 for DIN flanges.
- Make sure that the seals do not protrude into the piping cross-section.



#### Caution!

Risk of short circuit! Do not use electrically conductive sealing compound such as graphite. An electrically conductive layer could form on the inside of the measuring tube and short-circuit the measuring signal.

#### Ground cable

- If necessary, special ground cables can be ordered as accessories for potential equalization, → 47.
- For information on potential equalization and detailed installation instructions for using ground cables, please refer to → 29.

### Installing the high-temperature version (with PFA lining)

The high-temperature version has a housing support for the thermal separation of sensor and transmitter. The high-temperature version is always used for applications in which high ambient temperatures are encountered in conjunction with high fluid temperatures. The high-temperature version is obligatory if the fluid temperature exceeds  $+150\text{ °C}$  ( $+300\text{ °F}$ ).



Note!

You will find information on permissible temperature ranges on → 65

#### Insulation

Pipes generally have to be insulated if they carry very hot fluids to avoid energy losses and prevent accidental contact with pipes at temperatures that could cause injury. Guidelines regulating the insulation of pipes have to be taken into account.



Caution!

Risk of electronics overheating. The housing support dissipates heat and its entire surface area must remain uncovered. Make sure that the sensor insulation does not extend past the top of the two sensor half-shells.

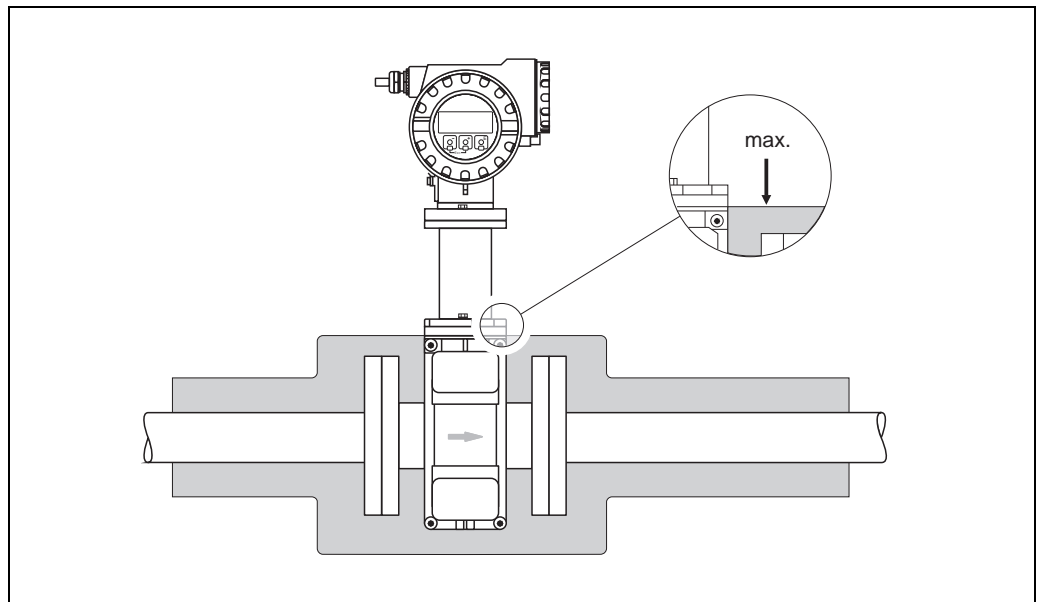

Fig. 14: Promag P sensor (high-temperature version): insulating the pipe

A0009742

### Screw tightening torques (Promag P)

Note the following points:

- The tightening torques listed below are for lubricated threads only.
- Always tighten the screws uniformly and in diagonally opposite sequence.
- Overtightening the screws will deform the sealing faces or damage the seals.
- The tightening torques listed below apply only to pipes not subjected to tensile stress.

Tightening torques for:

- EN (DIN) → 20
- ANSI → 20
- JIS → 21

#### Promag P tightening torques for EN (DIN)

Nominal diameter [mm]	EN (DIN) Pressure rating [bar]	Screws	Max. tightening torque [Nm]	
			PTFE	PFA
25	PN 40	4 × M 12	26	20
32	PN 40	4 × M 16	41	35
40	PN 40	4 × M 16	52	47
50	PN 40	4 × M 16	65	59
65 *	PN 16	8 × M 16	43	40
65	PN 40	8 × M 16	43	40
80	PN 16	8 × M 16	53	48
80	PN 40	8 × M 16	53	48
100	PN 16	8 × M 16	57	51
100	PN 40	8 × M 20	78	70
125	PN 16	8 × M 16	75	67
125	PN 40	8 × M 24	111	99
150	PN 16	8 × M 20	99	85
150	PN 40	8 × M 24	136	120
200	PN 10	8 × M 20	141	101
200	PN 16	12 × M 20	94	67
200	PN 25	12 × M 24	138	105

\* Designed acc. to EN 1092-1 (not to DIN 2501)

#### Promag P tightening torques for ANSI

Nominal diameter [mm]   [inch]		ANSI Pressure rating [lbs]	Screws	Max. tightening torque			
				PTFE		PFA	
				[Nm]	[lbf · ft]	[Nm]	[lbf · ft]
25	1"	Class 150	4 × ½"	11	8	10	7
25	1"	Class 300	4 × 5/8"	14	10	12	9
40	1½"	Class 150	4 × ½"	24	18	21	15
40	1½"	Class 300	4 × ¾"	34	25	31	23
50	2"	Class 150	4 × 5/8"	47	35	44	32
50	2"	Class 300	8 × 5/8"	23	17	22	16
80	3"	Class 150	4 × 5/8"	79	58	67	49
80	3"	Class 300	8 × ¾"	47	35	42	31
100	4"	Class 150	8 × 5/8"	56	41	50	37
100	4"	Class 300	8 × ¾"	67	49	59	44
150	6"	Class 150	8 × ¾"	106	78	86	63
150	6"	Class 300	12 × ¾"	73	54	67	49
200	8"	Class 150	8 × ¾"	143	105	109	80

*Promag P tightening torques for JIS*

Nominal diameter [mm]	JIS Pressure rating	Screws	Max. tightening torque [Nm]	
			PTFE	PFA
25	10K	4 × M 16	32	27
25	20K	4 × M 16	32	27
32	10K	4 × M 16	38	–
32	20K	4 × M 16	38	–
40	10K	4 × M 16	41	37
40	20K	4 × M 16	41	37
50	10K	4 × M 16	54	46
50	20K	8 × M 16	27	23
65	10K	4 × M 16	74	63
65	20K	8 × M 16	37	31
80	10K	8 × M 16	38	32
80	20K	8 × M 20	57	46
100	10K	8 × M 16	47	38
100	20K	8 × M 20	75	58
125	10K	8 × M 20	80	66
125	20K	8 × M 22	121	103
150	10K	8 × M 20	99	81
150	20K	12 × M 22	108	72
200	10K	12 × M 20	82	54
200	20K	12 × M 22	121	88

### 3.3.2 Installing the Promag H sensor

The sensor is supplied, as per your order, with or without installed process connections. Installed process connections are screwed onto the sensor using 4 or 6 hexagonal-headed bolts.



Caution!

Depending on the application and the length of the pipe, the sensor must be supported or more securely mounted if necessary. Particularly when using process connections made of plastic, it is essential that the sensor be mounted securely. A wall mounting kit for this purpose can be ordered separately as an accessory from Endress+Hauser (→ 47).

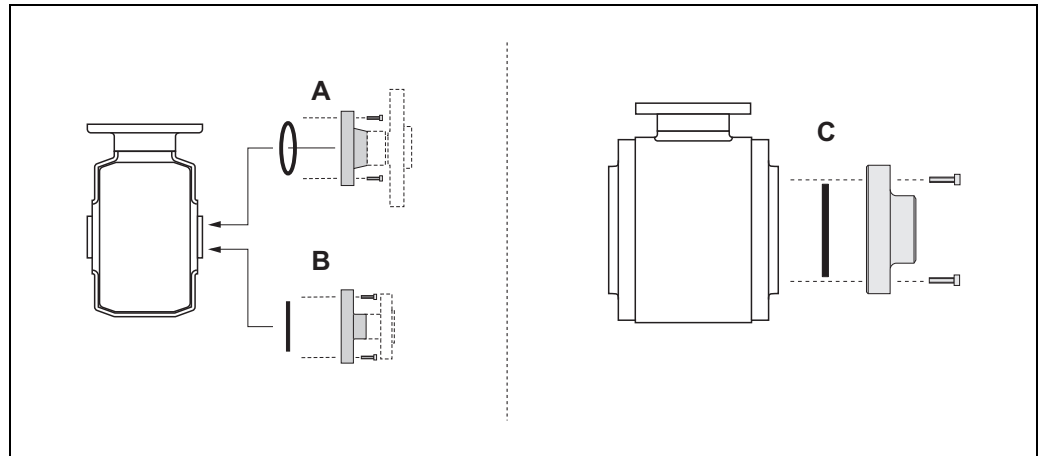

Fig. 15: Promag H process connections (DN 2 to 25 / 1/12 to 1" , DN 40 to 100 (1½ to 4"))

**A = DN 2 to 25 (1/12 to 1") / Process connections with O-ring**

- Weld nipple (DIN EN ISO 1127, ODT/SMS)
- Flange (EN (DIN), ANSI, JIS), flange made of PVDF (EN (DIN), ANSI, JIS)
- External thread, internal thread, hose connection, PVC adhesive fitting

**B = DN 2 to 25 (1/12 to 1") / Process connections with aseptic molded seal**

- Weld nipple (DIN 11850, ODT/SMS)
- Clamp (ISO 2852, DIN 32676, L14 AM7)
- Coupling (DIN 11851, DIN 11864-1, SMS 1145)
- Flange DIN 11864-2

**C = DN 40 to 100 (1½ to 4") / Process connections with aseptic molded seal**

- Weld nipple (DIN 11850, ODT/SMS)
- Clamp (ISO 2852, DIN 32676, L14 AM7)
- Coupling (DIN 11851, DIN 11864-1, ISO 2853, SMS 1145)
- Flange DIN 11864-2

#### Seals

When mounting the process connections, please ensure that the relevant seals are clean and properly centered.



Caution!

- In the case of metallic process connections, the screws must be fully tightened. The process connection forms a metallic connection with the sensor, which ensures a defined compression of the seal.
- In the case of process connections made of plastic, the maximum screw tightening torques for lubricated threads (7 Nm / 5.2 lbf ft) must be adhered to. In the case of plastic flanges, a seal must always be used between the connection and the counterflange.
- Depending on the application, the seals should be replaced periodically, particularly when molded seals (aseptic version) are used!

The interval between replacements depends on the frequency of the cleaning cycles and on the temperatures of the fluid and the cleaning process. Replacement seals can be ordered as an accessory at a later stage → 47.

### Using and installing grounding rings (DN 2 to 25 / 1/12 to 1")

In case the process connections are made of plastic (e.g. flanges or adhesive fittings), the potential between the sensor and the fluid must be equalised using additional ground rings.

If the ground rings are not installed this can affect the accuracy of the measurements or cause the destruction of the sensor through the galvanic corrosion of the electrodes.



#### Caution!

- Depending on the option ordered, plastic rings may be installed at the process connections instead of ground rings. These plastic rings serve only as spacers and have no potential equalization function. In addition, they provide a sealing function at the interface between the sensor and process connection. For this reason, with process connections without ground rings, these plastic rings/seals must not be removed, or must always be installed.
- Ground rings can be ordered separately from Endress+Hauser as accessories → 47. When placing the order, make certain that the ground ring is compatible with the material used for the electrodes. Otherwise, there is a risk that the electrodes may be destroyed by galvanic corrosion! Information about the materials can be found on → 70.
- Ground rings, including the seals, are mounted within the process connections. Therefore, the fitting length is not affected.

1. Loosen the four or six hexagonal headed bolts (1) and remove the process connection from the sensor (4).
2. Remove the plastic ring (3), including the two O-ring seals (2).
3. Place one seal (2) in the groove of the process connection.
4. Place the metal ground ring (3) on the process connection.
5. Now place the second seal (2) in the groove of the ground ring.
6. Finally, mount the process connection on the sensor again. With plastic process connections, note the max. torques for lubricated threads (7 Nm / 5.2 lbf ft).

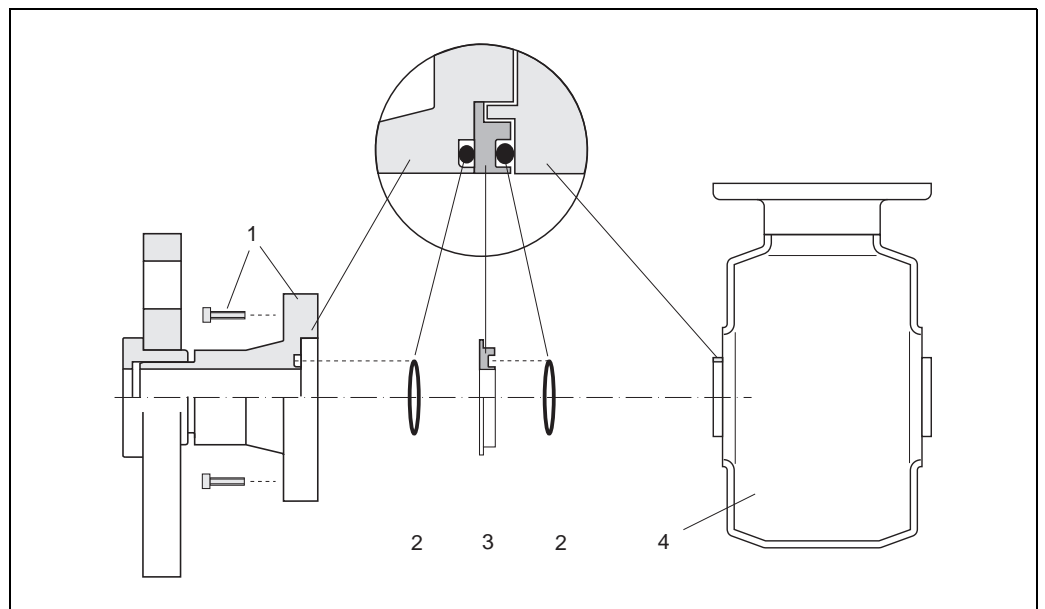

Fig. 16: Installing grounding rings in the Promag H (DN 2 to 25 / 1/12 to 1")

- 1 = Hexagonal-headed bolts, process connection  
 2 = O-ring seals  
 3 = Grounding ring or plastic ring (spacer)  
 4 = Sensor

### Welding the transmitter into the pipe (weld nipple)



#### Caution!

Risk of electronics being destroyed. Please ensure that the welding system is *not* grounded via the sensor or transmitter.

1. Secure the sensor using several welding points in the piping. A welding jig suitable for this purpose can be ordered separately as an accessory → 47.
2. Loosen the screws at the process connection flange, and remove the sensor incl. seal from the piping.
3. Weld the process connection into the pipe.
4. Mount the sensor back into the pipe. When doing so, make sure that the seal is clean and positioned correctly.



#### Note!

- If the welding is done properly with thin-walled food pipes, the seal will not be damaged by heat even when mounted. Nonetheless, it is recommended that you dismantle the sensor and seal.
- For dismantling purposes, it must be possible to open the piping a total of approx. 8 mm (0.31 in).

### Cleaning using pigs

When cleaning using pigs, please note the internal diameters of the measuring tube and the process connection. All the dimensions and lengths of the sensor and transmitter are provided in the separate documentation "Technical Information" → 73.



### 3.3.3 Turning the transmitter housing

1. Loosen the securing screw.
2. Turn the transmitter housing to the desired position (max. 360°).
3. Retighten the securing screw.

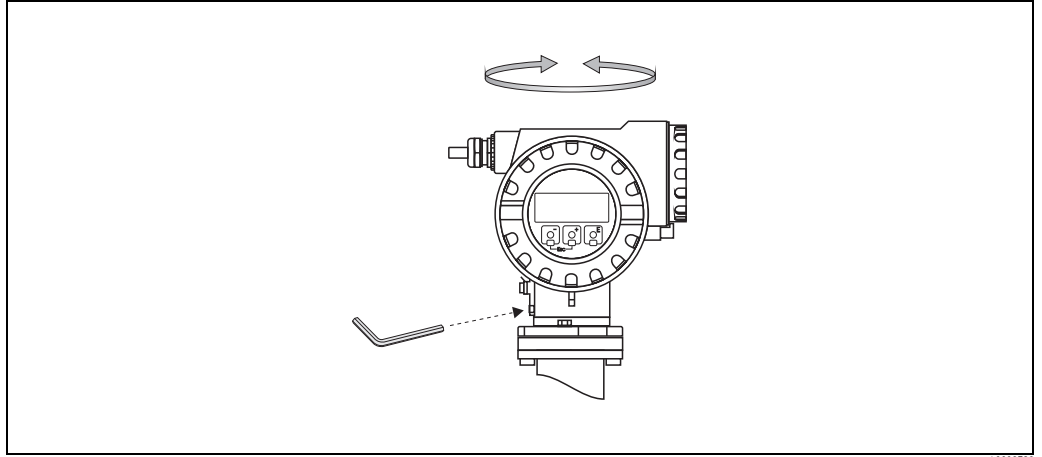

Fig. 17: Turning the transmitter housing

### 3.3.4 Turning the local display

1. Unscrew cover of the electronics compartment from the transmitter housing.
2. Remove the display module from the transmitter retaining rails.
3. Turn the display to the desired position (max.  $4 \times 45^\circ$  in each direction).
4. Fit the display back onto the retaining rails.
5. Screw the cover of the electronics compartment firmly back onto the transmitter housing.

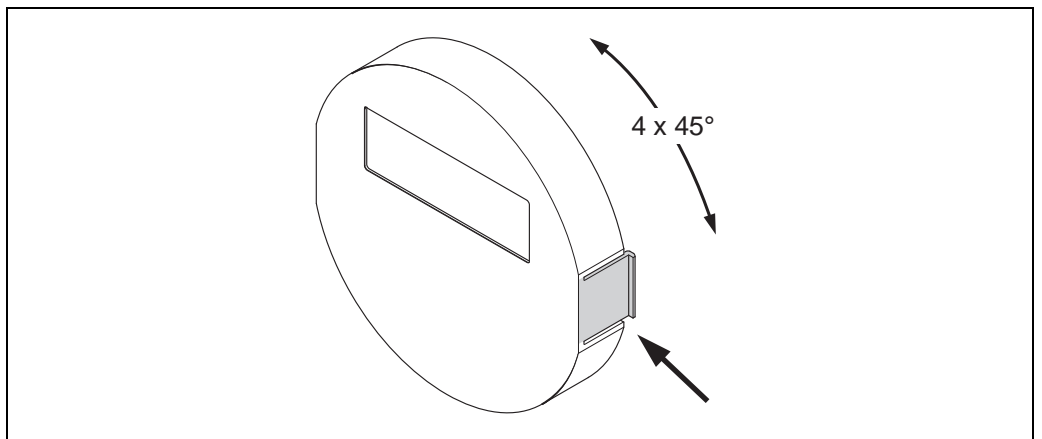

Fig. 18: Turning the local display

### 3.4 Post-installation check

Perform the following checks after installing the measuring device in the pipe:

Device condition/specifications	Notes
Is the device damaged (visual inspection)?	–
Does the device correspond to specifications at the measuring point, including process temperature and pressure, ambient temperature, minimum fluid conductivity, measuring range, etc.?	→ 65
Installation	Notes
Does the arrow on the sensor nameplate match the direction of flow through the pipe?	–
Is the position of the measuring electrode plane correct?	→ 14
Is the position of the empty pipe detection electrode correct?	→ 14
Were all screws tightened to the specified tightening torques when the sensor was installed?	→ 20
Were the correct seals installed (type, material, installation)?	Promag P → 18 Promag H → 22
Are the measuring point number and labeling correct (visual inspection)?	–
Process environment / process conditions	Notes
Are the inlet and outlet runs respected?	Inlet run $\geq 5 \times \text{DN}$ Outlet run $\geq 2 \times \text{DN}$
Is the measuring device protected against moisture and direct sunlight?	–
Is the sensor adequately protected against vibration (attachment, support)?	Acceleration up to 2 g in accordance with IEC 600 68-2-6 → 64

## 4 Wiring



### Warning!

When connecting Ex-certified devices, please take note of the instructions and wiring diagrams in the Ex-specific supplement to these Operating Instructions. Should you have any questions, please contact your Endress+Hauser sales office for assistance.



### Note!

The device does not have an internal circuit breaker. An external switch or circuit breaker must therefore be installed which can be used to disconnect the device from the main power source.

### 4.1 Connecting the measuring unit

#### 4.1.1 Connecting the transmitter



### Warning!

- Switch off the power supply before opening the device. **Do not** install or wire the device while it is connected to the power supply. Failure to comply with this precaution can result in irreparable damage to the electronics.
  - Compare the specifications on the nameplate with the local supply voltage and frequency. The national regulations governing the installation of electrical equipment also apply.
  - The transmitter must be included in the building fuse system.
1. Loosen the Allen-head screw (4) securing the clamp (3 mm key).
  2. Remove the cover of the connection compartment (5) from the transmitter housing.
  3. Feed the signal cable (1) through the appropriate cable entries.
  4. Connect the cables in accordance with the wiring diagram:
    - Wiring diagram → 19
    - Terminal assignment → 28
  5. Screw the cover of the connection compartment (5) firmly onto the transmitter housing.
  6. Retighten the socket-head screw (4) securing the clamp.

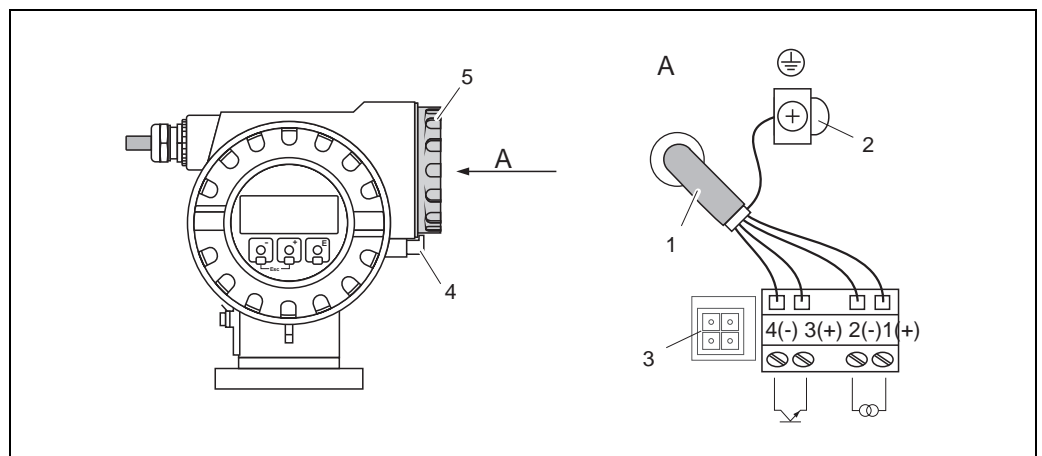

Fig. 19: Connecting the transmitter (aluminum field housing). Cable cross-section: max. 2.5 mm<sup>2</sup> (14 AWG)

- 1 Shielded signal cables:
  - Terminal No. 1(+)/ 2(-): power supply / current output
  - Terminal No. 3(+)/ 4(-): pulse / frequency output
- 2 Ground terminal for signal cable shield
- 3 Service connector
- 4 Securing clamp
- 5 Cover of the connection compartment

### 4.1.2 Terminal assignment

Order version	Terminal No. (outputs/power supply)	
	1(+) / 2(-)	3(+) / 4(-)
23***_*****A	Current output HART	Frequency output
23***_*****W	Current output HART	-



Note!

Functional values of the outputs and power supply → 60

### 4.1.3 HART connection

Users have the following connection options at their disposal:

- Direct connection to transmitter by means of terminals 1(+) and 2(-)
- Connection by means of the 4 to 20 mA circuit.



Hinweis!

- The measuring loop's minimum load must be at least 250 Ω.
- After commissioning, make the following settings:
  - CURRENT SPAN function → "4-20 mA HART" or "4-20 mA (25 mA) HART"
  - Switch HART write protection on or off → 41

#### Connection of the HART handheld communicator

See also the documentation issued by the HART Communication Foundation, and in particular HCF LIT 20: "HART, a technical summary".

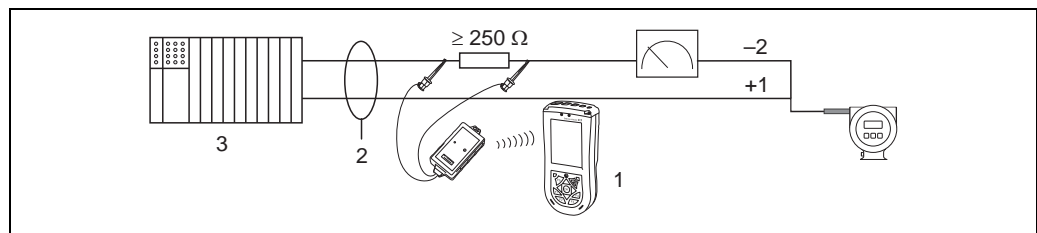

Fig. 20: Electrical connection of HART handheld Field Xpert SFX100

- 1 HART handheld Field Xpert SFX100
- 2 Shielding
- 3 Other devices or PLC with passive input

#### Connection of a PC with an operating software

In order to connect a PC with operating software (e.g. "FieldCare"), a HART modem (e.g. "Commubox FXA195") is needed.

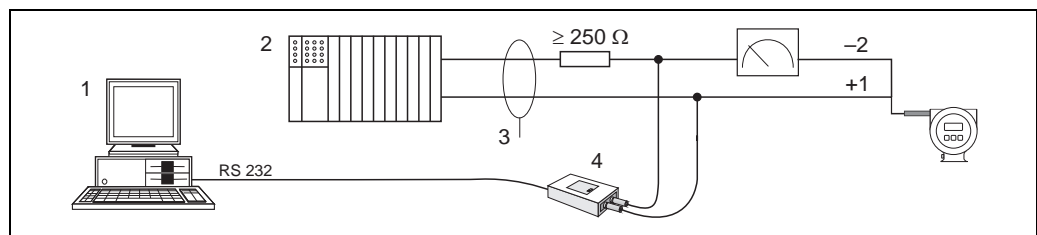

Fig. 21: Electrical connection of a PC with operating software

- 1 PC with operating software
- 2 Other devices or PLC with passive input
- 3 Shielding
- 4 HART modem, e.g. Commubox FXA195

## 4.2 Potential equalization



**Warning!**

The measuring system must be included in potential equalization.

Perfect measurement is only ensured when the medium and the sensor have the same electrical potential. Most Promag sensors have a reference electrode installed as standard, which guarantees the required potential equalization.

The following must also be taken into account for potential equalization:

- Company-internal grounding guidelines
- Operating conditions such as material/grounding of piping etc. (see table)

### 4.2.1 Potential equalization, Promag P

- Reference electrode available as standard
- Connection examples → [29](#)

### 4.2.2 Potential equalization, Promag H

No reference electrode available!

There is always one electrical connection to the fluid via the metallic process connection.



**Caution!**

When using process connections made of plastic, potential equalization must be guaranteed through the use of grounding rings → [23](#).

The necessary grounding rings may be ordered separately as an accessory from Endress+Hauser (→ [47](#)).

### 4.2.3 Connection examples for potential equalization

#### Standard case

Operating conditions	Potential equalization
<p>When using the measuring device in:</p> <ul style="list-style-type: none"> <li>■ metallic, grounded piping</li> </ul> <p>Potential equalization is carried out via the ground terminal of the transmitter.</p> <p> <b>Note!</b> For installation in metal pipes, it is advisable to connect the ground terminal of the transmitter housing to the piping.</p>	<p style="text-align: right; font-size: small;">A0013253</p> <p><i>Fig. 22: Via the transmitter's ground terminal</i></p>

**Special cases**

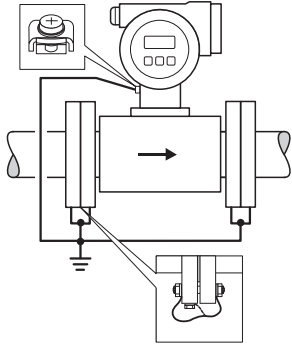
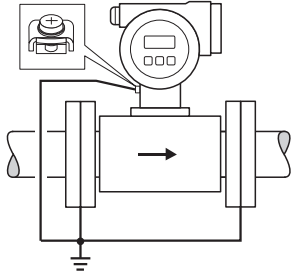
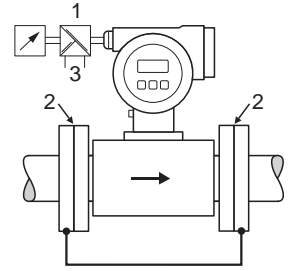
Operating conditions	Potential equalization
<p>When using the measuring device in:</p> <ul style="list-style-type: none"> <li>■ metallic, ungrounded piping</li> </ul> <p>This type of connection occurs when:</p> <ul style="list-style-type: none"> <li>■ the usual potential equalization cannot be guaranteed</li> <li>■ extremely high equalizing currents are expected</li> </ul> <p>A ground cable (copper wire, at least 6 mm<sup>2</sup> (0.0093 in<sup>2</sup>)) is used to connect both sensor flanges to the respective pipe flange and ground them. Connect the transmitter or sensor connection housing, as applicable, to ground potential by means of the ground terminal provided for the purpose.</p> <p>The ground cable is mounted directly on the conductive flange coating with flange screws.</p> <p> <b>Note!</b> The ground cable for flange-to-flange connections can be ordered separately as an accessory from Endress+Hauser.</p>	 <p style="text-align: right;"><small>A0009606</small></p> <p><i>Fig. 23: Via the transmitter's ground terminal and the pipe flanges</i></p>
<p>When using the measuring device in:</p> <ul style="list-style-type: none"> <li>■ Plastic pipes</li> <li>■ Isolating lined pipes</li> </ul> <p>This type of connection occurs when:</p> <ul style="list-style-type: none"> <li>■ the usual potential equalization cannot be guaranteed</li> <li>■ extremely high equalizing currents are expected</li> </ul> <p>Potential equalization takes place using additional ground disks, which are connected to the ground terminal via a ground cable (copper wire, min. 6 mm<sup>2</sup> (0.0093 in<sup>2</sup>)). When installing the ground disks, please comply with the enclosed Installation Instructions.</p>	 <p style="text-align: right;"><small>A0013260</small></p> <p><i>Fig. 24: Via the transmitter's ground terminal and the optionally available ground disks</i></p>
<p>When using the measuring device in:</p> <ul style="list-style-type: none"> <li>■ pipes with cathodic protection</li> </ul> <p>The device is installed in the pipeline in such a way that it is potential-free.</p> <p>Using a ground cable (copper wire, min. 6 mm<sup>2</sup> (0.0093 in<sup>2</sup>)), only the two pipe flanges are connected. When doing so, the ground cable is mounted directly on the conductive flange coating using flange screws.</p> <p>Please note the following during installation:</p> <ul style="list-style-type: none"> <li>■ The relevant regulations for potential-free installations must be observed.</li> <li>■ There must not be an electrically conductive connection between the piping and the device.</li> <li>■ The mounting material must be able to withstand the relevant torques.</li> </ul>	 <p style="text-align: right;"><small>A0009608</small></p> <p><i>Fig. 25: Potential equalization and cathodic protection</i></p> <p>1 Transmitter power supply (active barrier) 2 Electrically isolated 2 External power supply</p>

## 4.3 Degree of protection

The devices fulfill all the requirements for IP 67.

Compliance with the following points is mandatory following installation in the field or servicing, in order to ensure that IP 67 protection is maintained:

- The housing seals must be clean and undamaged when inserted into their grooves. The seals must be dried, cleaned or replaced if necessary.
- All housing screws and screw covers must be firmly tightened.
- The cables used for connection must be of the specified external diameter → 62.
- Tighten cable glands.
- The cables must loop down before they enter the cable entries ("water trap"). This arrangement prevents moisture penetrating the entry. Always install the measuring device in such a way that the cable entries do not point up.
- Close off unused cable entries using suitable insert plugs.
- Do not remove the grommet from the cable entry.

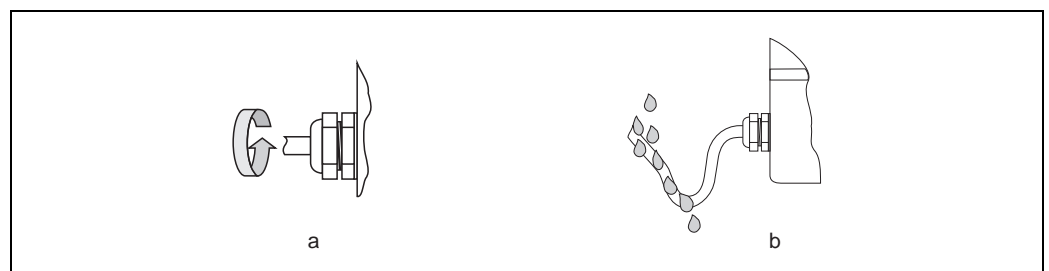

Fig. 26: Installation instructions, cable entries



**Caution!**

Do not loosen the screws of the sensor housing as otherwise the degree of protection guaranteed by Endress+Hauser no longer applies.

## 4.4 Post-connection check

Perform the following checks after completing electrical installation of the measuring device:

Device condition and specifications	Notes
Are cables or the device damaged (visual inspection)?	–
Electrical connection	Notes
Does the supply voltage match the specifications on the nameplate?	12 to 30 V DC 13.9 to 30 V DC (Ex i)
Do the cables used comply with the necessary specifications?	→ 62
Do the cables have adequate strain relief?	–
Is the cable type route completely isolated? Without loops and crossovers?	–
Are the power-supply and signal cables correctly connected?	See the wiring diagram inside the cover of the connection compartment
Are all screw terminals firmly tightened?	–
Have the measures for grounding/potential equalization been correctly implemented?	→ 29
Are all cable entries installed, firmly tightened and correctly sealed? Cables looped as "water traps"?	→ 31
Are all housing covers installed and firmly tightened?	–

## 5 Operation

### 5.1 Display and operating elements

The local display enables you to read important parameters directly at the measuring point or to configure your device using the function matrix.

The display area consists of two lines; this is where measured values are displayed, and/or status variables (partially filled pipe, etc.). The assignment of the display lines in operating mode is specified. The top line displays the volume flow and the bottom line displays the totalizer status.

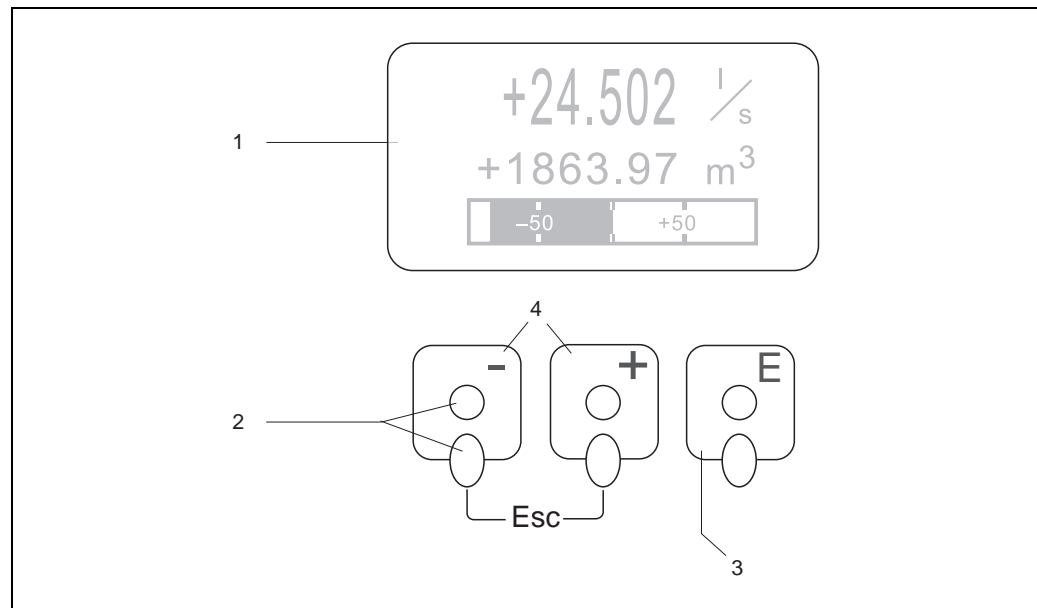

A0009737

Fig. 27: Display and operating elements

- 1 **Liquid crystal display**  
The backlit, four-line liquid crystal display shows measured values, dialog texts, fault messages and notice messages. The display as it appears when normal measuring is in progress is known as the HOME position (operating mode display).
- 2 **Optical sensors for Touch Control**
- 3 **Enter key (Enter key)**
  - HOME position → Entry into the function matrix
  - Save the numerical values you input or settings you change
- 4 **Minus/Plus keys**
  - HOME position → Direct access to totalizer values and actual values of inputs/outputs
  - Enter numerical values, select parameters
  - Select different blocks, groups and function groups within the function matrix

Press the **Minus/Plus** keys **simultaneously** to trigger the following functions:

  - Exit the function matrix step by step → HOME position
  - Press and hold down the **Minus/Plus** keys for longer than 3 seconds → Return directly to the HOME position
  - Cancel data entry



### 5.1.1 Display (operating mode)

The display area consists of three lines in all; this is where measured values are displayed, and/or status variables (direction of flow, bar graph, etc.). You can change the assignment of display lines to variables at will in order to customize the display to suit your needs and preferences (→ see the "Description of Device Functions" manual).

*Error messages:*

Display and presentation of system/process errors → 36

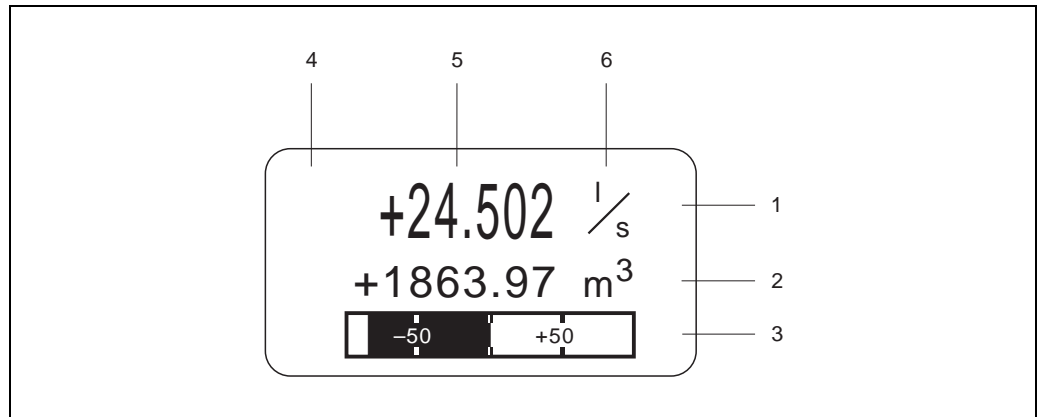

Fig. 28: Typical display for normal operating mode (HOME position)

- 1 Main line shows main measured values, e.g. flow
- 2 Supplementary line shows supplementary measured or status variables, e.g. totalizer reading.
- 3 Information line shows additional information on measured or status variables, e.g. bar graph representation of the full scale value attained by the flow rate
- 4 "Info icons" field shows additional information in the form of icons on the measured values displayed. A complete overview of all icons and their meaning can be found on → 33
- 5 "Measured values" field shows the current measured values
- 6 "Engineering unit" field shows the engineering units and time units defined for the current measured values.

### 5.1.2 Additional display functions

From HOME position, use the  $\boxed{+}\boxed{-}$  keys to open an "Info Menu" containing the following information:

- Totalizer (including overflow)
- Actual values or states of the configured inputs/outputs
- Device TAG number (user-definable)

$\boxed{+}\boxed{-}$  → Scan of individual values within the Info Menu

$\boxed{\text{Esc}}$  (Esc key) → Back to HOME position

### 5.1.3 Icons

The icons which appear in the field on the left make it easier to read and recognize measured variables, device status, and error messages.

Icon	Meaning	Icon	Meaning
S	System error	P	Process error
⚡	Fault message (with effect on outputs)	!	Notice message (without effect on outputs)

## 5.2 Brief Operating Instructions for the function matrix



Note!

- See the general notes → 35
  - Function descriptions → See the "Description of Device Functions" manual
1. HOME position → **E** → Enter the function matrix
  2. **+ / -** → Select a block (e.g. MEASURED VARIABLES) → **E**
  3. **+ / -** → Select a group (e.g. CURRENT OUTPUT 1) → **E**
  4. **+ / -** → Select a function group (e.g. CONFIGURATION) → **E**
  5. Select a function (e.g. TIME CONSTANT) and change parameters/enter numerical values:
    - + -** → Select or enter release code, parameters, numerical values
    - E** → Save entries
  6. Exit the function matrix:
    - Press and hold down Esc key (**Esc**) for longer than 3 seconds → HOME position
    - Repeatedly press Esc key (**Esc**) → Return step by step to HOME position

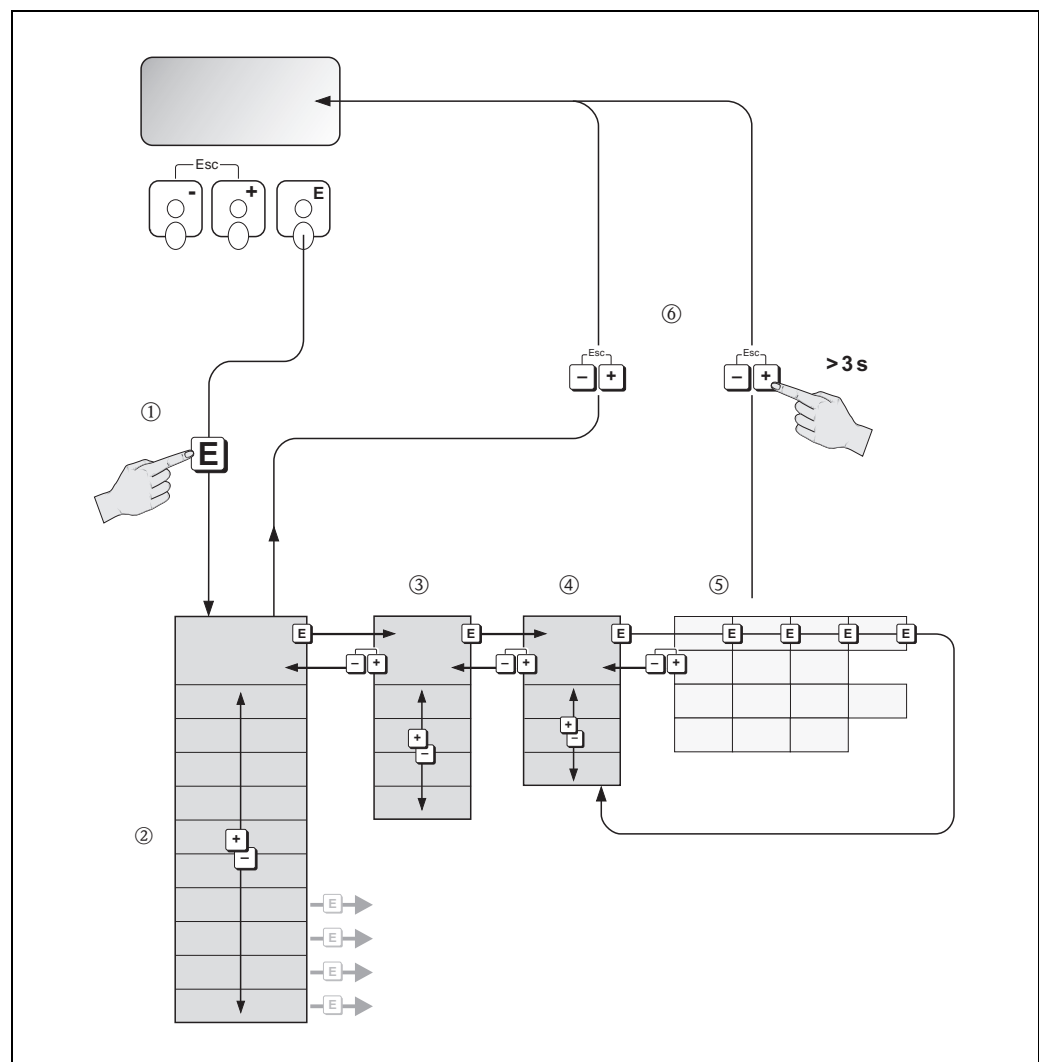





Fig. 29: Selecting functions and configuring parameters (function matrix)

### 5.2.1 General notes

The function matrix comprises a multiplicity of additional functions which, for the sake of clarity, are arranged on a number of menu levels (blocks, groups, and function groups).

Comply with the following instructions when configuring functions:

- You select functions as described →  34.
- You can switch off certain functions (OFF). If you do so, related functions in other function groups will no longer be displayed.
- Certain functions prompt you to confirm your data entries. Press / to select "SURE [ YES ]" and press  again to confirm. This saves your setting or starts a function, as applicable.
- Return to the HOME position is automatic if no key is pressed for 5 minutes.
- Programming mode is automatically disabled if you do not press a key within 60 seconds following automatic return to the HOME position.



Note!

- The transmitter continues to measure while data entry is in progress, i.e. the current measured values are output via the signal outputs in the normal way.
- If the power supply fails, all preset and parameterized values remain safely stored in the EEPROM.



Note!



All functions are described in detail, including the function matrix itself, in the "Description of Device Functions" manual, which is a separate part of these Operating Instructions.

### 5.2.2 Enabling the programming mode

The function matrix can be disabled. Disabling the function matrix rules out the possibility of inadvertent changes to device functions, numerical values or factory settings. A numerical code (factory setting = 23) has to be entered before settings can be changed.

If you use a code number of your choice, you exclude the possibility of unauthorized persons accessing data (→ "Description of Device Functions" manual).

Comply with the following instructions when entering codes:

- If programming is disabled and the / keys are pressed in any function, a prompt for the code automatically appears on the display.
- If "0" is entered as the customer's code, programming is always enabled.
- The Endress+Hauser service organization can be of assistance if you mislay your personal code.



Caution!

Changing certain parameters such as all sensor characteristics, for example, influences numerous functions of the entire measuring system, particularly measuring accuracy. There is no need to change these parameters under normal circumstances and consequently, they are protected by a special code known only to the Endress+Hauser service organization. Please contact Endress+Hauser first if you have any questions.

### 5.2.3 Disabling the programming mode

Programming mode is disabled if you do not press a key within 60 seconds following automatic return to the HOME position.

You can also disable programming in the ACCESS CODE function by entering any number (other than the customer's code).

## 5.3 Error messages

### 5.3.1 Type of error

Errors which occur during commissioning or measuring operation are displayed immediately. If two or more system or process errors occur, the error with the highest priority is the one shown on the display.

The measuring system distinguishes between two types of error:

- **System errors:** This group comprises all device errors, e.g. communication errors, hardware errors, etc. → 51
- **Process error:** This group includes all application errors e.g. empty pipe, etc. → 53

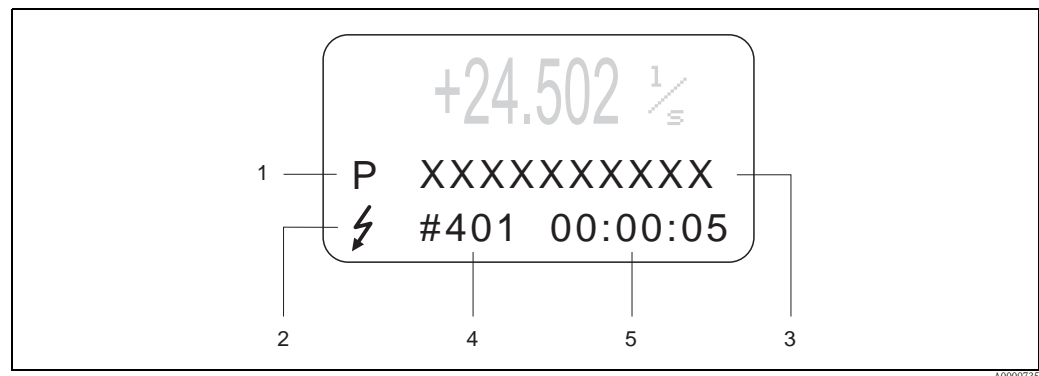

Fig. 30: Error messages on the display (example)

- 1 Error type: P = process error, S = system error
- 2 Error message type: ⚡ = fault message, ! = notice message
- 3 Error designation
- 4 Error number
- 5 Duration of most recent error occurrence (hours : minutes : seconds)

### 5.3.2 Error message type

Users have the option of weighting system and process errors differently, by defining them as **Fault messages** or **Notice messages**. You can define messages in this way with the aid of the function matrix (see the "Description of Device Functions" manual).

Serious system errors, e.g. module defects, are always identified and classed as "fault messages" by the measuring device.

Notice message (!)

- Displayed as → Exclamation mark (!), type of error (S: system error, P: process error)
- The error in question has no effect on the current measuring operation and the outputs of the measuring device.

Fault message (⚡)

- Displayed as → Lightning flash (⚡), type of error (S: system error, P: process error)
- The error in question interrupts or stops the current measuring operation and has an immediate effect on the outputs. The response of the outputs (failsafe mode) can be defined by means of functions in the function matrix → 55.



Note!

- Error conditions can be output via the relay outputs.
- If an error message occurs, an upper or lower signal level for the breakdown information according to NAMUR 43 can be output via the current output.

### 5.3.3 Confirming error messages

For the sake of plant and process safety, the measuring device can be configured in such a way that fault messages displayed (⚡) always have to be rectified and acknowledged locally by pressing . Only then do the error messages disappear from the display.

This option can be switched on or off by means of the "ACKNOWLEDGE FAULT MESSAGES" function (see the "Description of Device Functions" manual).



Note!

- Fault messages (⚡) can also be reset and confirmed via the status input.
- Notice messages (!) do not require acknowledgment. Note, however, that they remain visible until the cause of the error has been rectified.

## 5.4 Communication

In addition to local operation, the measuring device can be configured and measured values can be obtained by means of the HART protocol. Digital communication takes place using the 4–20 mA current output HART →  28.

The HART protocol allows the transfer of measuring and device data between the HART master and the field devices for configuration and diagnostics purposes. The HART master, e.g. a handheld terminal or PC-based operating programs (such as FieldCare), require device description (DD) files which are used to access all the information in a HART device. Information is exclusively transferred using so-called "commands". There are three different command groups:

There are three different command groups:

- *Universal commands*

All HART device support and use universal commands. The following functionalities, for example, are linked to them:

- Identify HART devices
- Reading digital measured values (volume flow, totalizer, etc.)

- *Common practice commands:*

Common practice commands offer functions which are supported and can be executed by most but not all field devices.

- *Device-specific commands:*

These commands allow access to device-specific functions which are not HART standard. Amongst other things, such commands access individual field device information, such as empty-pipe/full-pipe calibration values, low flow cutoff settings, etc.



Note!

The device has access to all three command classes.

List of all "universal commands" →  39.

### 5.4.1 Operating options

For the complete operation of the measuring device, including device-specific commands, there are DD files available to the user to provide the following operating aids and programs:



Note!

- In the CURRENT SPAN function (current output 1), the HART protocol demands the setting "4-20 mA HART" or "4-20 mA (25 mA) HART".
- HART write protection can be enabled or disabled by means of a jumper on the I/O board  
→ 41

#### Field Xpert HART Communicator

Selecting device functions with a HART Communicator is a process involving a number of menu levels and a special HART function matrix.

The HART manual in the carrying case of the HART Communicator contains more detailed information on the device.

#### Operating program "FieldCare"

Fieldcare is Endress+Hauser's FDT-based plant Asset Management Tool and allows the configuration and diagnosis of intelligent field devices. By using status information, you also have a simple but effective tool for monitoring devices. The Proline flow measuring devices are accessed via a service interface or via the service interface FXA193.

#### Operating program "SIMATIC PDM" (Siemens)

SIMATIC PDM is a standardized, manufacturer-independent tool for the operation, configuration, maintenance and diagnosis of intelligent field devices.

#### Operating program "AMS" (Emerson Process Management)

AMS (Asset Management Solutions): program for operating and configuring devices.

### 5.4.2 Current device description files

The following table illustrates the suitable device description file for the operating tool in question and then indicates where these can be obtained.

HART protocol:

<b>Valid for software</b>	2.02.XX	→ "Device software" function
<b>Device data HART</b>		
Manufacturer ID:	11 <sub>hex</sub> (ENDRESS+HAUSER)	→ "Manufact ID" function
Device ID:	42 <sub>hex</sub>	→ "Device ID" function
<b>HART version data</b>	Device Revision 6/ DD Revision 1	
<b>Software release</b>	05.2009	
<b>Operating</b>	<b>Sources for obtaining device descriptions</b>	
Handheld terminal Field Xpert SFX100	Use update function of handheld terminal	
FieldCare / DTM	<ul style="list-style-type: none"> <li>■ www.endress.com → Download</li> <li>■ CD-ROM (Endress+Hauser order number 56004088)</li> <li>■ DVD (Endress+Hauser order number 70100690)</li> </ul>	
AMS	www.endress.com → Download	
SIMATIC PDM	www.endress.com → Download	
<b>Tester/simulator</b>	<b>Sources for obtaining device descriptions</b>	
Fieldcheck	Update via FieldCare using the Flow Device FXA193/291 DTM in the Fieldflash module	

### 5.4.3 Universal/Common practice HART commands

Command No. HART command / Access type		Command data (numeric data in decimal form)	Response data (numeric data in decimal form)
<b>Universal Commands</b>			
0	Read unique device identifier Access type = read	none	<p>Device identification delivers information on the device and the manufacturer. It cannot be changed.</p> <p>The response consists of a 12 byte device ID:</p> <ul style="list-style-type: none"> <li>– Byte 0: fixed value 254</li> <li>– Byte 1: Manufacturer ID, 17 = E+H</li> <li>– Byte 2: Device type ID, e.g. 70 = Promag 23</li> <li>– Byte 3: Number of preambles</li> <li>– Byte 4: Universal commands rev. no.</li> <li>– Byte 5: Device-specific rev. no. Commands</li> <li>– Byte 6: Software revision</li> <li>– Byte 7: Hardware revision</li> <li>– Byte 8: Additional device information</li> <li>– Bytes 9-11: Device identification</li> </ul>
1	Read primary process variable Access type = read	none	<ul style="list-style-type: none"> <li>– Byte 0: HART unit code of the primary process variable</li> <li>– Bytes 1-4: Primary process variable</li> </ul> <p><i>Factory setting:</i> Primary process variable = Volume flow</p> <p> <b>Note!</b> Manufacturer-specific units are represented using the HART unit code "240".</p>
2	Read the primary process variable as current in mA and percentage of the set measuring range Access type = read	none	<ul style="list-style-type: none"> <li>– Bytes 0-3: actual current of the primary process variable in mA</li> <li>– Bytes 4-7: Percentage of the set measuring range</li> </ul> <p><i>Factory setting:</i> Primary process variable = Volume flow</p>
3	Read the primary process variable as current in mA and four dynamic process variables Access type = read	none	<p>24 bytes are sent as a response:</p> <ul style="list-style-type: none"> <li>– Bytes 0-3: primary process variable current in mA</li> <li>– Byte 4: HART unit code of the primary process variable</li> <li>– Bytes 5-8: Primary process variable</li> <li>– Byte 9: HART unit code of the second process variable</li> <li>– Bytes 10-13: Second process variable</li> <li>– Byte 14: HART unit code of the third process variable</li> <li>– Bytes 15-18: Third process variable</li> <li>– Byte 19: HART unit code of the fourth process variable</li> <li>– Bytes 20-23: Fourth process variable</li> </ul> <p><i>Factory setting:</i></p> <ul style="list-style-type: none"> <li>■ Primary process variable = Volume flow</li> <li>■ Second process variable = Totalizer 1</li> <li>■ Third process variable = Mass flow</li> <li>■ Fourth process variable = OFF (not assigned)</li> </ul> <p> <b>Note!</b> Manufacturer-specific units are represented using the HART unit code "240".</p>
6	Set HART shortform address Access type = write	<p>Byte 0: desired address (0 to 15)</p> <p><i>Factory setting:</i> 0</p> <p> <b>Note!</b> With an address &gt;0 (multidrop mode), the current output of the primary process variable is set to 4 mA.</p>	Byte 0: active address

Command No. HART command / Access type		Command data (numeric data in decimal form)	Response data (numeric data in decimal form)
11	Read unique device identification using the TAG (measuring point designation) Access type = read	Bytes 0-5: TAG	Device identification delivers information on the device and the manufacturer. It cannot be changed. The response consists of a 12 byte device ID if the given TAG agrees with the one saved in the device: <ul style="list-style-type: none"> <li>- Byte 0: fixed value 254</li> <li>- Byte 1: Manufacturer ID, 17 = E+H</li> <li>- Byte 2: Device type ID, 70 = Promag 23</li> <li>- Byte 3: Number of preambles</li> <li>- Byte 4: Universal commands rev. no.</li> <li>- Byte 5: Device-specific rev. no. Commands</li> <li>- Byte 6: Software revision</li> <li>- Byte 7: Hardware revision</li> <li>- Byte 8: Additional device information</li> <li>- Bytes 9-11: Device identification</li> </ul>
12	Read user message Access type = read	none	Bytes 0-24: User message  Note! You can write the user message using Command 17.
13	Read TAG, descriptor and date Access type = read	none	<ul style="list-style-type: none"> <li>- Bytes 0-5: TAG</li> <li>- Bytes 6-17: descriptor</li> <li>- Bytes 18-20: Date</li> </ul>  Note! You can write the TAG, descriptor and date using Command 18.
14	Read sensor information on primary process variable	none	<ul style="list-style-type: none"> <li>- Bytes 0-2: Sensor serial number</li> <li>- Byte 3: HART unit code of sensor limits and measuring range of the primary process variable</li> <li>- Bytes 4-7: Upper sensor limit</li> <li>- Bytes 8-11: Lower sensor limit</li> <li>- Bytes 12-15: Minimum span</li> </ul>  Note! <ul style="list-style-type: none"> <li>■ The data relate to the primary process variable (= volume flow).</li> <li>■ Manufacturer-specific units are represented using the HART unit code "240".</li> </ul>
15	Read output information of primary process variable Access type = read	none	<ul style="list-style-type: none"> <li>- Byte 0: Alarm selection ID</li> <li>- Byte 1: Transfer function ID</li> <li>- Byte 2: HART unit code for the set measuring range of the primary process variable</li> <li>- Bytes 3-6: End of measuring range, value for 20 mA</li> <li>- Bytes 7-10: Start of measuring range, value for 4 mA</li> <li>- Bytes 11-14: Attenuation constant in [s]</li> <li>- Byte 15: Write protection ID</li> <li>- Byte 16: OEM dealer ID, 17 = E+H</li> </ul> <i>Factory setting:</i> Primary process variable = Volume flow  Note! Manufacturer-specific units are represented using the HART unit code "240".
16	Read the device production number Access type = read	none	Bytes 0-2: Production number
17	Write user message Access = write	You can save any 32-character long text in the device under this parameter: Bytes 0-23: Desired user message	Displays the current user message in the device: Bytes 0-23: Current user message in the device
18	Write TAG, descriptor and date Access = write	With this parameter, you can store an 8 character TAG, a 16 character descriptor and a date: <ul style="list-style-type: none"> <li>- Bytes 0-5: TAG</li> <li>- Bytes 6-17: descriptor</li> <li>- Bytes 18-20: Date</li> </ul>	Displays the current information in the device: <ul style="list-style-type: none"> <li>- Bytes 0-5: TAG</li> <li>- Bytes 6-17: descriptor</li> <li>- Bytes 18-20: Date</li> </ul>



### 5.4.4 Switching HART write protection on and off

A jumper on the I/O board provides the means of activating or deactivating HART write protection.



**Warning!**

Risk of electric shock. Exposed components carry dangerous voltages. Make sure that the power supply is switched off before you remove the cover of the electronics compartment.

1. Switch off power supply.
2. Remove the I/O board (1) → 57.
3. Remove cover plate (3).
4. Switch HART write protection (2) on or off, as applicable, by means of the jumper (→ 31).
5. Installation of the I/O board is the reverse of the removal procedure.

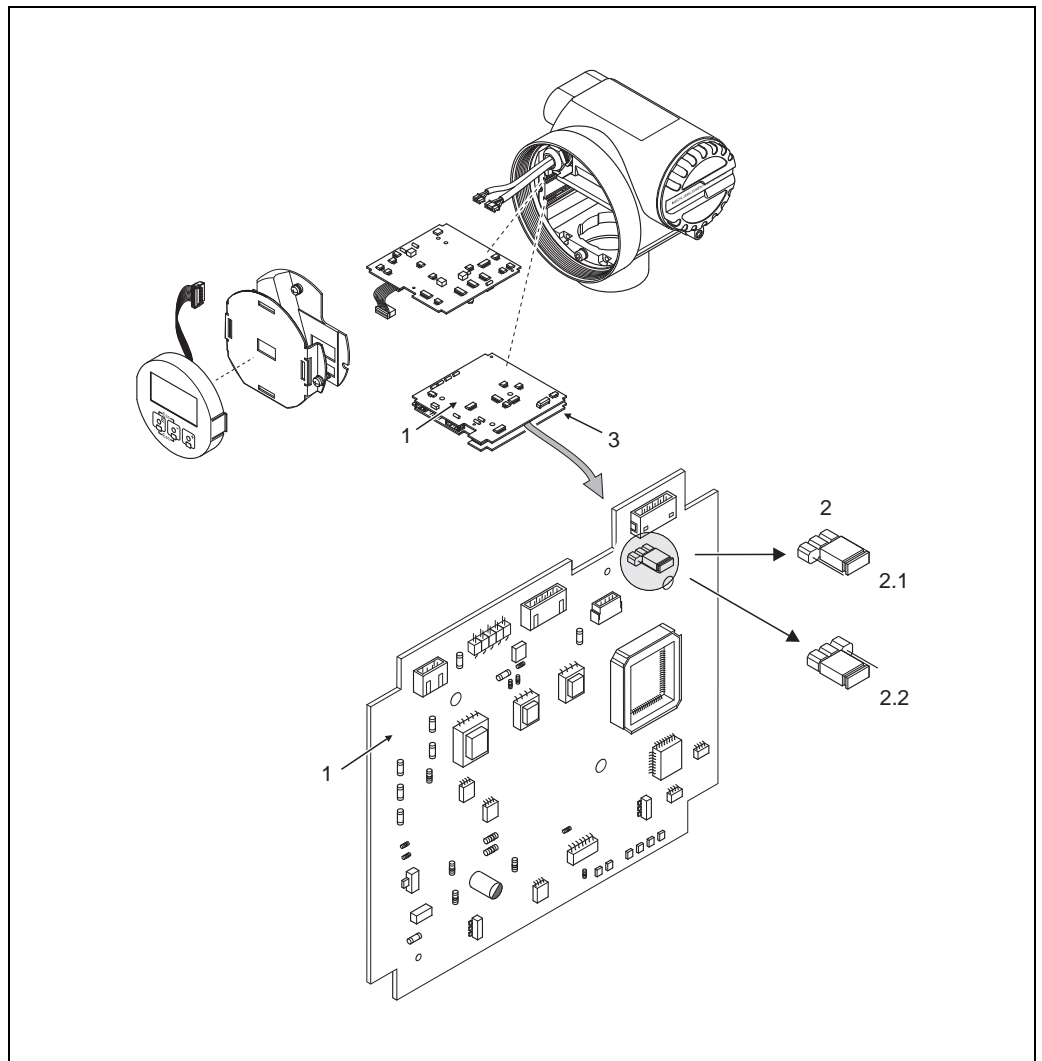

Fig. 31: Switching HART write protection on and off

- 1 I/O board
- 2 Jumper for HART write protection
- 2.1 Write protection OFF (default), i.e. HART protocol unlocked
- 2.2 Write protection ON, i.e. HART protocol locked
- 3 Cover plate

## 6 Commissioning

### 6.1 Function check

Make sure that all final checks have been completed before you start up your measuring point:

- Checklist for "Post-installation check" → [26](#)
- Checklist for "Post-connection check" → [31](#)

### 6.2 Switching on the measuring device

Once the connection checks have been successfully completed, it is time to switch on the power supply. The device is now operational.

The measuring device performs a number of post switch-on self-tests. As this procedure progresses the following sequence of messages appears on the local display:

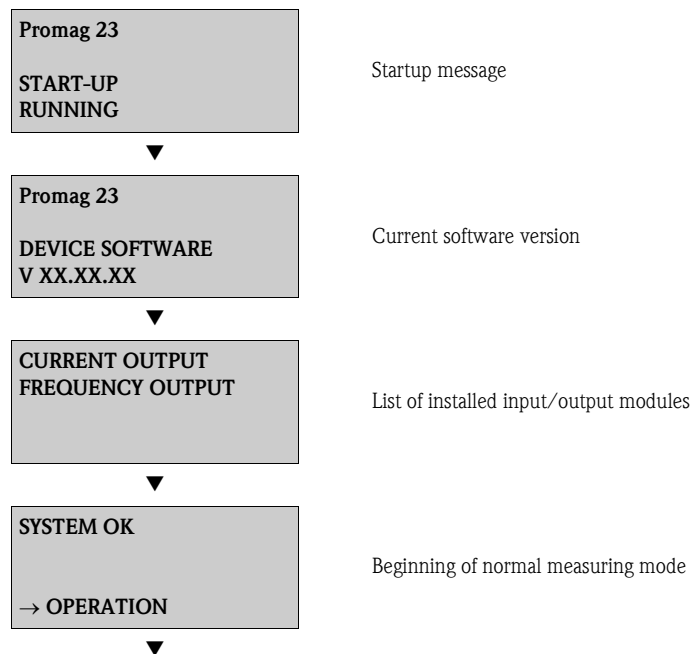

Normal measuring mode commences as soon as startup completes. Various measured value and/or status variables appear on the display (HOME position).



Note!

- If startup fails, an error message indicating the cause is displayed.
- The local display is inoperative if the device is connected to the FieldCare.

## 6.3 Data backup/transmission

Using the T-DAT SAVE/LOAD function, you can transfer data (device parameters and settings) between the T-DAT (exchangeable memory) and the EEPROM (device storage unit).

This is required in the following instances:

- Creating a backup: current data are transferred from an EEPROM to the T-DAT.
- Replacing a transmitter: current data are copied from an EEPROM to the T-DAT and then transferred to the EEPROM of the new transmitter.
- Duplicating data: current data are copied from an EEPROM to the T-DAT and then transferred to EEPROMs of identical measuring points.



Note!

For information on installing and removing the T-DAT → [57](#).

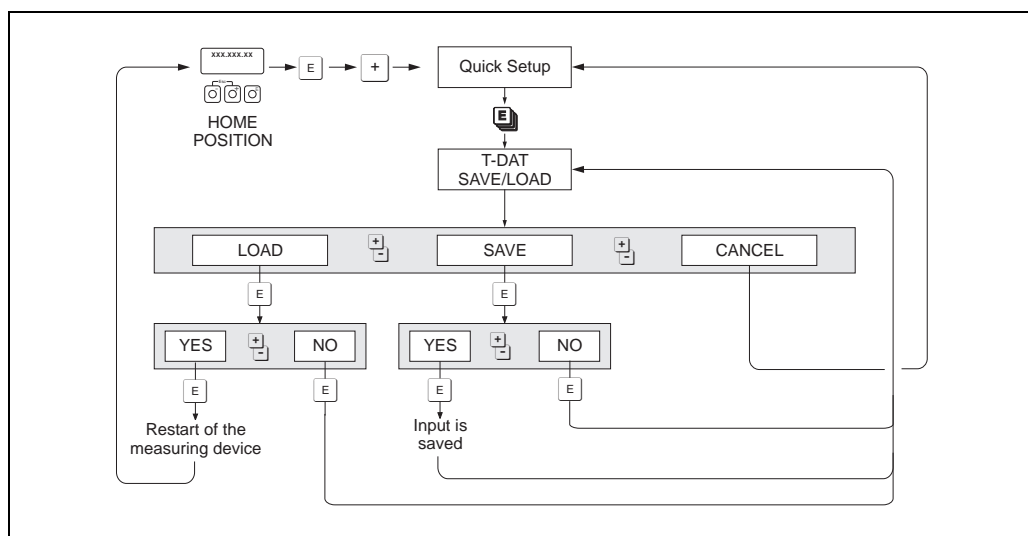

Fig. 32: Data backup/transmission with T-DAT SAVE/LOAD function

Information on the LOAD and SAVE options available:

**LOAD:** Data are transferred from the T-DAT to the EEPROM.



Note!

- Any settings already saved on the EEPROM are deleted.
- This option is only available, if the T-DAT contains valid data.
- This option can only be executed if the software version of the T-DAT is the same or newer than that of the EEPROM. Otherwise, the error message "TRANSM. SW-DAT" appears after restarting and the LOAD function is then no longer available.

**SAVE:**

Data are transferred from the EEPROM to the T-DAT.

## 6.4 Adjustment

### 6.4.1 Empty-pipe/Full-pipe adjustment

Flow cannot be measured correctly unless the measuring pipe is completely full.

This status can be monitored at all times with the Empty Pipe Detection function:

EPD = Empty Pipe Detection (with the help of an EPD electrode)

The EPD function cannot be activated until after empty/full pipe calibration has been performed.

This adjustment procedure is described below.



Note!

- The EPD function is not available unless the sensor is fitted with an EPD electrode.
- The devices are already calibrated at the factory with water (approx. 500 µS/cm). If the liquid conductivity differs from this reference, empty-pipe/full-pipe adjustment has to be performed again on site.
- The default setting for EPD when the devices are delivered is OFF; the function has to be activated if required.
- The EPD process error can be output by means of the pulse/frequency output.

#### Response to partially filled pipe

If EPD is on and trips in response to a partially filled or empty measuring tube, the message "EMPTY PIPE" appears on the local display and zero flow is displayed.

If the pipe is partially filled and EPD is not on, response can vary in identically configured systems: flow reading fluctuates, zero flow, excessively high flow readings

#### Performing empty-pipe and full-pipe adjustment (EPD)

1. Select the corresponding function in the function matrix:  
HOME → → → BASIC FUNCTIONS → → → PROCESS PARAMETERS  
→ → → → EPD ADJUSTMENT
2. Empty the piping. In case of an EPD adjustment, the wall of the measuring tube should be wetted with fluid.
3. Start empty-pipe adjustment: Select "EMPTY PIPE ADJUST" and press to confirm.
4. After empty-pipe adjustment, fill the piping with fluid.
5. Start full-pipe adjustment: Select "FULL PIPE ADJUST" and press to confirm.
6. Having completed the adjustment, select the setting "OFF" and exit the function by pressing .
7. Now select the "EPD" function. Switch on Empty Pipe Detection: Select ON and press to confirm.



Caution!

The adjustment coefficients must be valid before you can activate the EPD function. If adjustment is incorrect the following messages might appear on the display:

- ADJUSTMENT FULL = EMPTY

The adjustment values for empty pipe and full pipe are identical. In such instances, empty-pipe adjustment/full-pipe adjustment **must** be carried out again.

- ADJUSTMENT NOT OK

Adjustment is not possible because the fluid's conductivity is out of range.

In cases of this nature you must repeat empty-pipe or full-pipe calibration!

## 6.5 Data storage devices

At Endress+Hauser, the term HistoROM refers to various types of data storage modules on which process and measuring device data are stored. By plugging and unplugging such modules, device configurations can be duplicated onto other measuring devices to cite just one example.

### 6.5.1 HistoROM/S-DAT (sensor DAT)

The S-DAT is an exchangeable data storage device in which all sensor data are stored, i.e., nominal diameter, serial number, calibration factor, zero point.

### 6.5.2 HistoROM/T-DAT (transmitter DAT)

The T-DAT is an exchangeable data storage device in which all transmitter parameters and settings are stored.

Storing of specific parameter settings from the device memory (EEPROM) to the T-DAT module and vice versa must be carried out by the user (= manual save function). Detailed instructions regarding this can be found on →  43.

## **7 Maintenance**

No special maintenance work is required.

### **7.1 Exterior cleaning**

When cleaning the exterior of measuring devices, always use cleaning agents that do not attack the surface of the housing or the seals.

### **7.2 Seals**

The seals in the Promag H sensor should be replaced periodically, particularly when molded seals (aseptic version) are used!

The interval between replacements depends on the frequency of the cleaning cycles and on the temperature of the fluid and of the cleaning process.

Replacement seals (accessory) →  47.

## 8 Accessories

Various accessories, which can be ordered separately from Endress+Hauser, are available for the transmitter and the sensor. Your Endress+Hauser service organization can provide detailed information on the order code of your choice.

### 8.1 Device-specific accessories

Accessory	Description	Order code
Transmitter Proline Promag 23	Transmitter for replacement or for stock. Use the order code to define the following specifications: <ul style="list-style-type: none"> <li>– Approvals</li> <li>– Degree of protection / version</li> <li>– Cable entries</li> <li>– Display / power supply / operation</li> <li>– Software</li> <li>– Outputs</li> </ul>	23XXX – XXXXX*****

### 8.2 Accessories specific to measuring principle

Accessory	Description	Order code
Ground cable for Promag P	A set consists of two ground cables.	DK5GC – * * *
Ground disk for Promag P	Ground disk for potential equalization.	DK5GD – * * * * *
Mounting kit for Promag H	Mounting kit for Promag H, consisting of: <ul style="list-style-type: none"> <li>■ 2 Process connections</li> <li>■ Screws</li> <li>■ Seals</li> </ul>	DKH * * – * * * * *
Adapter connection for Promag A/H	Adapter connections for installation of Promag 23 H instead of Promag 30/33 A or Promag 30/33 H (DN 25).	DK5HA – * * * * * *
Grounding rings for Promag H	If the process connections are made of PVC or PVDF, ground rings are necessary to ensure that potential is matched. A set comprises 2 ground rings.	DK5HR – * * *
Seal set for Promag H	For regular replacement of seals in the Promag H sensor.	DK5HS – * * *
Wall mounting kit Promag H	Wall mounting kit for Promag H transmitter.	DK5HM – * *
Welding jig for Promag H	Weld nipple as process connection: Welding jig for installation in piping.	DK5HW – * * *

### 8.3 Communication-specific accessories

Accessory	Description	Order code
HART Communicator Field Xpert SFX 100	Handheld terminal for remote configuration and for obtaining measured values via the 4 to 20 mA HART current output. Contact your Endress+Hauser representative for more information.	SFX100 – *****
Fieldgate FXA320	Gateway for remote interrogation of HART sensors and actuators via Web browser: <ul style="list-style-type: none"> <li>■ 2-channel analog input (4 to 20 mA)</li> <li>■ 4 binary inputs with event counter function and frequency measurement</li> <li>■ Communication via modem, Ethernet or GSM</li> <li>■ Visualization via Internet/Intranet in Web browser and/or WAP cellular phone</li> <li>■ Limit value monitoring with alarm by e-mail or SMS</li> <li>■ Synchronized time stamping of all measured values.</li> </ul>	FXA320 – *****
Fieldgate FXA520	Gateway for remote interrogation of HART sensors and actuators via Web browser: <ul style="list-style-type: none"> <li>■ Web server for remote monitoring of up to 30 measuring points</li> <li>■ Intrinsically safe version [EEx ia]IIC for applications in hazardous areas</li> <li>■ Communication via modem, Ethernet or GSM</li> <li>■ Visualization via Internet/Intranet in Web browser and/or WAP cellular phone</li> <li>■ Limit value monitoring with alarm by e-mail or SMS</li> <li>■ Synchronized time stamping of all measured values</li> <li>■ Remote diagnosis and remote configuration of connected HART devices</li> </ul>	FXA520 – *****
FXA195	The Commubox FXA195 connects intrinsically safe Smart transmitters with HART protocol to the USB port of a personal computer. This makes the remote operation of the transmitters possible with the aid of configuration programs (e.g. FieldCare). Power is supplied to the Commubox by means of the USB port	FXA195 – *



## 8.4 Service-specific accessories

Accessory	Description	Order code
Applicator	Software for selecting and configuring flowmeters. Applicator can be downloaded from the Internet or ordered on CD-ROM for installation on a local PC. Contact your Endress+Hauser representative for more information.	DXA80 – *
FieldCare	FieldCare is Endress+Hauser's FDT-based plant asset management tool. It can configure all intelligent field devices in your plant and supports you in the administration of these devices. Through the use of status information, it is also an easy but effective means of monitoring the status of these devices.	See product list on the Endress+Hauser website: <a href="http://www.endress.com">www.endress.com</a>
Memograph M graphic display recorder	The Memograph M graphic display recorder provides information on all the relevant process variables. Measured values are recorded correctly, limit values are monitored and measuring points analyzed. The data are stored in the 256 MB internal memory and also on a DSD card or USB stick. Memograph M boasts a modular design, intuitive operation and a comprehensive security concept. The ReadWin® 2000 PC software is part of the standard package and is used for configuring, visualizing and archiving the data captured. The mathematics channels which are optionally available enable continuous monitoring of specific power consumption, boiler efficiency and other parameters which are important for efficient energy management.	RSG40 – *****
FXA193	Service interface of device to the PC for operation via FieldCare.	FXA193 – *

# 9 Troubleshooting

## 9.1 Troubleshooting instructions

If faults occur after commissioning or during operation, always start troubleshooting with the checklist below. The routine takes you directly to the cause of the problem and the appropriate remedial measures.

Check the display	
No display visible and no output signals present.	<ol style="list-style-type: none"> <li>1. Check the supply voltage → terminals 1, 2</li> <li>2. Measuring electronics defective → order spare parts →  47</li> </ol>
No display visible, but output signals are present.	<ol style="list-style-type: none"> <li>1. Check whether the ribbon-cable connector of the display module is correctly plugged into the amplifier board →  56</li> <li>2. Display module defective → order spare parts →  47</li> <li>3. Measuring electronics defective → order spare parts →  47</li> </ol>
Display texts are in a foreign language.	Switch off power supply. Press and hold down both the   buttons and switch on the measuring device. The display text will appear in English (default) and is displayed at maximum contrast.
Measured value indicated, but no signal at the current or pulse output.	Electronics board defective → order spare parts →  47
↓	
Error messages on display	
<p>Errors which occur during commissioning or operation are displayed immediately. Error messages consist of a variety of icons. The meanings of these icons are as follows (example):</p> <ul style="list-style-type: none"> <li>- Error type: <b>S</b> = system error, <b>P</b> = process error</li> <li>- Error message type:  = fault message,  = notice message</li> <li>- <b>EMPTY PIPE</b> = type of error, e.g. measuring tube is only partly filled or completely empty</li> <li>- <b>03:00:05</b> = duration of error occurrence (in hours, minutes and seconds)</li> <li>- <b>#401</b> = error number</li> </ul> <p> <b>Caution!</b></p> <ul style="list-style-type: none"> <li>■ Also observe the information on →  36</li> <li>■ The measuring system interprets simulations and positive zero return as system errors, but displays them only as a notice message.</li> </ul>	
Error number: No. 001 – 399 No. 501 – 699	System error (device error) has occurred →  51
Error number: No. 401 – 499	Process error (application error) has occurred →  53
↓	
Other errors (without error message)	
Some other errors have occurred.	Diagnosis and rectification →  54

## 9.2 System error messages

Serious system errors are **always** recognized by the device as "Fault message", and are shown as a lightning flash (⚡) on the display. Fault messages immediately affect the outputs.



Caution!

In the event of a serious fault, a flowmeter might have to be returned to the manufacturer for repair. The necessary procedures must be carried out before you return the device to Endress+Hauser → 59. Always enclose a duly completed "Declaration of Contamination" form. You will find a preprinted blank of this form at the back of this manual.



Note!

Also observe the information on → 50.

No.	Error message / Type	Cause	Remedy (spare part → 56)
S = System error ⚡ = Fault message (with an effect on the outputs) ! = Notice message (without an effect on the outputs)			
<b>No. # Oxx → Hardware error</b>			
001	S: CRITICAL FAILURE ⚡: # 001	Serious device error	Replace the amplifier board.
011	S: AMP HW EEPROM ⚡: # 011	Amplifier: Defective EEPROM	Replace the amplifier board.
012	S: AMP SW EEPROM ⚡: # 012	Amplifier: Error accessing EEPROM data	The EEPROM data blocks in which an error has occurred are displayed in the TROUBLESHOOTING function. Press Enter to acknowledge the errors in question; default values are automatically inserted instead of the errored parameter values. Note! The measuring device has to be restarted if an error has occurred in a totalizer block (see error No. 111 / CHECKSUM TOTAL).
031	S: SENSOR HW DAT ⚡: # 031	1. S-DAT is not plugged into the amplifier board correctly (or is missing). 2. S-DAT is defective.	1. Check whether the S-DAT is correctly plugged into the amplifier board. 2. Replace the S-DAT if it is defective. Check that the new replacement DAT is compatible with the measuring electronics. Check the: – Spare part set number – Hardware revision code 3. Replace measuring electronics boards if necessary. 4. Plug the S-DAT into the amplifier board.
032	S: SENSOR SW DAT ⚡: # 032		
041	S: TRANSM. HW-DAT ⚡: # 041	Transmitter DAT: 1. T DAT is not correctly plugged into the amplifier board (or is missing). 2. T-DAT is defective.	1. Check whether the T-DAT is correctly plugged into the amplifier board. 2. Replace the T-DAT if it is defective. Check that the new replacement DAT is compatible with the measuring electronics. Check the: – Spare part set number – Hardware revision code 3. Replace measuring electronics boards if necessary. 4. Plug the T-DAT into the amplifier board.
042	S: TRANSM. SW-DAT ⚡: # 042	Transmitter DAT: Error accessing the calibration values stored in the S-DAT.	
051	S: A / C COMPATIB. ⚡: # 051	The I/O board and the amplifier board are not compatible.	Use only compatible modules and boards. Check the compatibility of the modules used. Check the: ■ Spare part set number ■ Hardware revision code
<b>No. # 1xx → Software error</b>			

No.	Error message / Type	Cause	Remedy (spare part → 56)
111	S: CHECKSUM TOTAL !: # 111	Totalizer checksum error.	<ol style="list-style-type: none"> <li>Restart the measuring device.</li> <li>Replace the amplifier board if necessary.</li> </ol>
<b>No. # 2xx → Error in DAT / no communication</b>			
205	S: LOAD T-DAT !: # 205	Transmitter DAT: Data backup (downloading) to T-DAT failed, or error when accessing (uploading) the calibration values stored in the T-DAT.	<ol style="list-style-type: none"> <li>Check whether the T-DAT is correctly plugged into the amplifier board → 57</li> <li>Replace the T-DAT if it is defective. Before replacing the DAT, check that the new, replacement DAT is compatible with the measuring electronics. Check the:                             <ul style="list-style-type: none"> <li>– Spare part set number</li> <li>– Hardware revision code</li> </ul> </li> <li>Replace measuring electronics boards if necessary.</li> </ol>
206	S: SAVE T-DAT !: # 206		
261	S: COMMUNICATION I/O !: # 261	No data reception between amplifier and I/O board or faulty internal data transfer.	Check the BUS contacts.
<b>No. # 3xx → System limits exceeded</b>			
321	S: TOL. COIL CURR. !: # 321	Sensor: Coil current is out of tolerance.	<p> <b>Warning!</b> Switch off power supply before manipulating the coil current cable, coil current cable connector or measuring electronics boards! If the error can not be resolved, please contact your local Endress+Hauser service organization.</p>
351	S: CURRENT RANGE !: # 351	Current output: flow is out of range.	<ol style="list-style-type: none"> <li>Change the upper or lower limit setting, as applicable.</li> <li>Increase or reduce flow, as applicable.</li> </ol>
355	S: FREQ. RANGE n !: # 355	Frequency output: flow is out of range.	<ol style="list-style-type: none"> <li>Change the upper or lower limit setting, as applicable.</li> <li>Increase or reduce flow, as applicable.</li> </ol>
359	S: PULSE RANGE !: # 359	Pulse output: the pulse output frequency is out of range.	<ol style="list-style-type: none"> <li>Increase the setting for pulse weighting</li> <li>When selecting the pulse width, choose a value that can still be processed by a connected counter (e.g. mechanical counter, PLC etc.). <i>Determine the pulse width:</i> <ul style="list-style-type: none"> <li>– Variant 1: Enter the minimum duration that a pulse must be present at the connected counter to ensure its registration.</li> <li>– Variant 2: Enter the maximum (pulse) frequency as the half "reciprocal value" that a pulse must be present at the connected counter to ensure its registration.</li> </ul>                     Example: The maximum input frequency of the connected counter is 10 Hz. The pulse width to be entered is:                     <math display="block">\frac{1}{2 \cdot 10 \text{ Hz}} = 50 \text{ ms}</math> </li> <li>Reduce flow.</li> </ol>
<b>No. # 6xx → Simulation mode active</b>			
601	S: POS. ZERO-RETURN !: # 601	Positive zero return active  <b>Caution!</b> This message has the highest display priority!	Switch off positive zero return
611	S: SIM. CURR. OUT. n !: # 611	Simulation current output active	Switch off simulation
621	S: SIM. FREQ. OUT. n !: # 621	Simulation frequency output active	Switch off simulation
631	S: SIM. PULSE n !: # 631	Simulation pulse output active	Switch off simulation
641	S: SIM. STAT. OUT n !: # 641	Simulation status output active	Switch off simulation
691	S: SIM. FAILSAFE !: # 691	Simulation of response to error (outputs) active	Switch off simulation
692	S: SIM. MEASURAND !: # 692	Simulation of a measured variable active (e.g. mass flow).	Switch off simulation

### 9.3 Process error messages







Note!

Also observe the information on → 50.

No.	Error message / Type	Cause	Remedy (spare part → 56ff)
P = Process error † = Fault message (with an effect on the outputs) ! = Notice message (without an effect on the outputs)			
401	EMPTY PIPE †: # 401	Measuring tube partially filled or empty	1. Check the process conditions of the plant 2. Fill the measuring tube
461	ADJ. NOT OK !: # 461	EPD calibration not possible because the fluid's conductivity is either too low or too high.	The EPD function cannot be used with fluids of this nature.
463	FULL = EMPTY †: # 463	The EPD calibration values for empty pipe and full pipe are identical, therefore incorrect.	Repeat calibration, making sure procedure is correct → 44.

## 9.4 Process errors without messages

Symptoms	Rectification
<p> <b>Note!</b> You may have to change or correct certain settings in functions in the function matrix in order to rectify the fault. The functions outlined below, such as DISPLAY DAMPING, are described in detail in the "Description of Device Functions" manual.</p>	
Flow values are negative, even though the fluid is flowing forwards through the pipe.	Change the setting in the "INSTALLATION DIRECTION SENSOR" function accordingly
Measured-value reading fluctuates even though flow is steady.	<ol style="list-style-type: none"> <li>1. Check grounding and potential equalization →  29</li> <li>2. The medium is too inhomogeneous. Check the following medium characteristics: <ul style="list-style-type: none"> <li>– Gas bubble percentage too high?</li> <li>– Solids percentage too high?</li> <li>– Conductivity fluctuations too high?</li> </ul> </li> <li>3. SYSTEM DAMPING function → increase value (→ BASIC FUNCTION/SYSTEMPARAMETER/CONFIGURATION)</li> <li>4. TIME CONSTANT function → increase value (→ OUTPUTS/CURRENT OUTPUT/CONFIGURATION)</li> <li>5. DISPLAY DAMPING function → increase value (→ USER INTERFACE / CONTROL/BASIC CONFIGURATION)</li> </ol>
Measured-value reading or measured-value output pulsates or fluctuates, e.g. because of reciprocating pump, peristaltic pump, diaphragm pump or pump with similar delivery characteristic.	<ol style="list-style-type: none"> <li>1. TIME CONSTANT function → increase value (→ OUTPUTS/CURRENT OUTPUT/CONFIGURATION)</li> <li>2. If the problem persists despite these measures, a pulsation damper will have to be installed between pump and measuring device.</li> </ol>
There are differences between the flowmeter's internal totalizer and the external metering device.	This symptom is due primarily to backflow in the piping, because the pulse output cannot subtract in the STANDARD or SYMMETRY measuring modes.
Measured-value reading shown on display, even though the fluid is at a standstill and the measuring tube is full.	<ol style="list-style-type: none"> <li>1. Check grounding and potential equalization →  28</li> <li>2. Check the fluid for presence of gas bubbles.</li> <li>3. Activate ON-VALUE LOW FLOW CUT OFF function, i.e. enter or increase on value (→ BASIC FUNCTION/PROCESSPARAMETER/CONFIGURATION).</li> </ol>
Measured-value reading on display, even though measuring tube is empty.	<ol style="list-style-type: none"> <li>1. Perform empty-pipe/full-pipe adjustment and then switch on empty pipe detection →  44</li> <li>2. Fill the measuring tube.</li> </ol>
The current output signal is always 4 mA, irrespective of the flow signal at any given time.	<ol style="list-style-type: none"> <li>1. Select the BUS ADDRESS function and change the setting to "0".</li> <li>2. Low flow cutoff too high → reduce the relevant value in the ON-VALUE LOW FLOW CUT OFF function.</li> <li>3. The nominal diameter value of the sensor in the software doesn't comply with the actual nominal diameter.</li> <li>4. If the full scale value setting is 4 mA, this value is too low. If the full scale value setting is 20 mA, this value is too high.</li> </ol>
<p>The fault cannot be rectified or some other fault not described above has arisen.</p> <p>In these instances, please contact your Endress+Hauser service organization.</p>	<p>The following options are available for tackling problems of this nature:</p> <ul style="list-style-type: none"> <li>■ <b>Request the services of an Endress+Hauser service technician</b> If you contact our service organization to have a service technician sent out, please be ready to quote the following information: <ul style="list-style-type: none"> <li>– Brief description of the fault</li> <li>– Nameplate specifications (→  7): order code, serial number</li> </ul> </li> <li>■ <b>Returning devices to Endress+Hauser</b> The necessary procedures (→  59) must be carried out before you return a flowmeter requiring repair or calibration to Endress+Hauser. Always enclose a duly completed "Declaration of Conformity" form with the flowmeter. You will find a master copy of this form at the back of this manual.</li> <li>■ <b>Replace transmitter electronics</b> Components in the measuring electronics defective → order spare parts →  47</li> </ul>

## 9.5 Response of outputs to errors



### Note!

The failsafe mode of totalizers, current, pulse and status outputs can be customized by means of various functions in the function matrix. You will find detailed information on these procedures in the "Description of Device Functions" manual.

You can use positive zero return to reset the signals of the current, pulse and status outputs to their fallback value, for example when measuring has to be interrupted while a pipe is being cleaned. This function takes priority over all other device functions: simulations, for example, are suppressed.

Error response mode of outputs and totalizers		
	System/process error is current	Positive zero return is activated
<b>Caution!</b> System or process errors defined as "Notice messages" have no effect whatsoever on the inputs and outputs. See the information on → 50.		
Current output	MINIMUM VALUE 4–20 mA HART → 2 mA 4–20 mA HART NAMUR → 3.5 mA 4–20 mA HART US → 3.75 mA  MAXIMUM VALUE 4–20 mA HART → 22 mA 4–20 mA HART NAMUR → 22.6 mA 4–20 mA HART US → 22.6 mA  HOLD VALUE Last valid value (preceding occurrence of the fault) is output.  ACTUAL VALUE Fault is ignored, i.e. normal measured-value output on the basis of ongoing flow measurement.	Output signal corresponds to "zero flow"
Pulse output	FALLBACK VALUE Signal output → no pulses  HOLD VALUE Last valid value (preceding occurrence of the fault) is output.  ACTUAL VALUE Fault is ignored, i.e. normal measured-value output on the basis of ongoing flow measurement.	Output signal corresponds to "zero flow"
Frequency output	FALLBACK VALUE Signal output → 0 Hz  FAILSAFE LEVEL Output of the frequency specified in the FAILSAFE VALUE function.  HOLD VALUE Last valid value (preceding occurrence of the fault) is output.  ACTUAL VALUE Fault is ignored, i.e. normal measured-value output on the basis of ongoing flow measurement.	Output signal corresponds to "zero flow"
Totalizer	STOP The totalizers are paused until the fault is rectified.  ACTUAL VALUE The fault is ignored . The totalizers continue to count in accordance with the current flow value.  HOLD VALUE The totalizers continue to count the flow in accordance with the last valid flow value (before the error occurred).	Totalizer stops
Status output (Pulse/frequency output)	In the event of a fault or power supply failure: Status output → de-energized  Detailed information on switching response: → "Description of Device Functions" manual	No effect on relay output

## 9.6 Spare parts

You will find detailed troubleshooting instructions in the preceding sections → 50. The measuring device, moreover, provides additional support in the form of continuous self-diagnosis and error messages.

Fault rectification can entail replacing defective components with tested spare parts. The illustration below shows the available scope of spare parts.



Note!

You can order spare parts directly from your Endress+Hauser service organization by providing the serial number printed on the transmitter nameplate → 7.

Spare parts are shipped as sets comprising the following parts:

- Spare part
- Additional parts, small items (screws, etc.)
- Mounting instructions
- Packaging

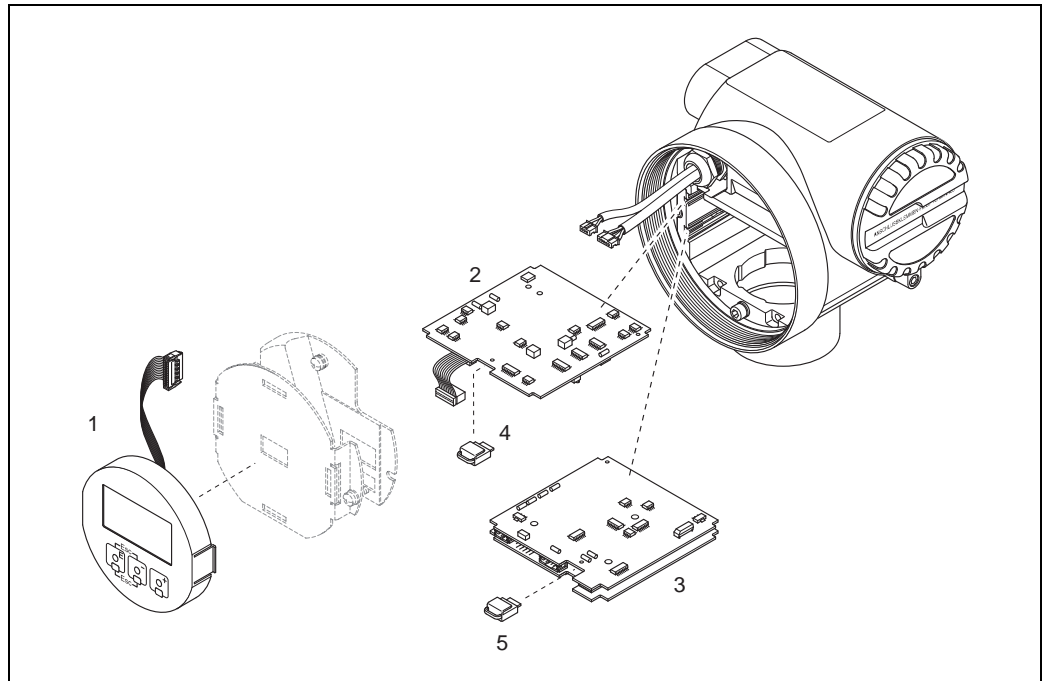

Fig. 33: Spare parts for transmitter

- 1 Display module
- 2 Amplifier board
- 3 I/O board
- 4 S-DAT (sensor data storage device)
- 5 T-DAT (transmitter data storage device)



## 9.6.1 Removing and installing electronics boards

**Field housing: Removing and installing electronics boards** →  34



**Warning!**

- Risk of electric shock!  
Exposed components carry dangerous voltages. Make sure that the power supply is switched off before you remove the cover of the electronics compartment.
- Risk of damaging electronic components (ESD protection)!  
Static electricity can damage electronic components or impair their operability. Use a workplace with a grounded working surface purpose-built for electrostatically sensitive devices!
- If you cannot guarantee that the dielectric strength of the device is maintained in the following steps, then an appropriate inspection must be carried out in accordance with the manufacturer's specifications.



**Caution!**

- Always remove the I/O board first and reinstall it last.
- When reassembling, make sure that the coil current cable (8) and the electrode signal cable (5) are correctly reinserted into their retaining clips!
- Use only original Endress+Hauser parts.



**Note!**

Removing and installing the boards →  34:

1. Switch off the power supply.
2. Unscrew cover of the electronics compartment from the transmitter housing.
3. Remove the mounting plate (2) complete with display module (3).
4. Disconnect the following plugs from the measuring amplifier board (14):
  - Display module ribbon-cable plug (4)
  - Plug of the electrode signal cable (5)
5. Remove the screws and remove the cover (6) from the electronics compartment.
6. Disconnect the following cable plugs from the electronics boards:
  - Plug of connecting cable (7) between measuring amplifier and I/O board.
  - Plug of coil current cable (8)
  - Plug of service cable (9)
  - Plug of cable for feed/output signals (10)
  - S-DAT (11)
  - T-DAT (12)
7. Remove the I/O board (13) and then the measuring amplifier board (14) from the transmitter housing.
8. Installation is the reverse of the disassembly procedure.

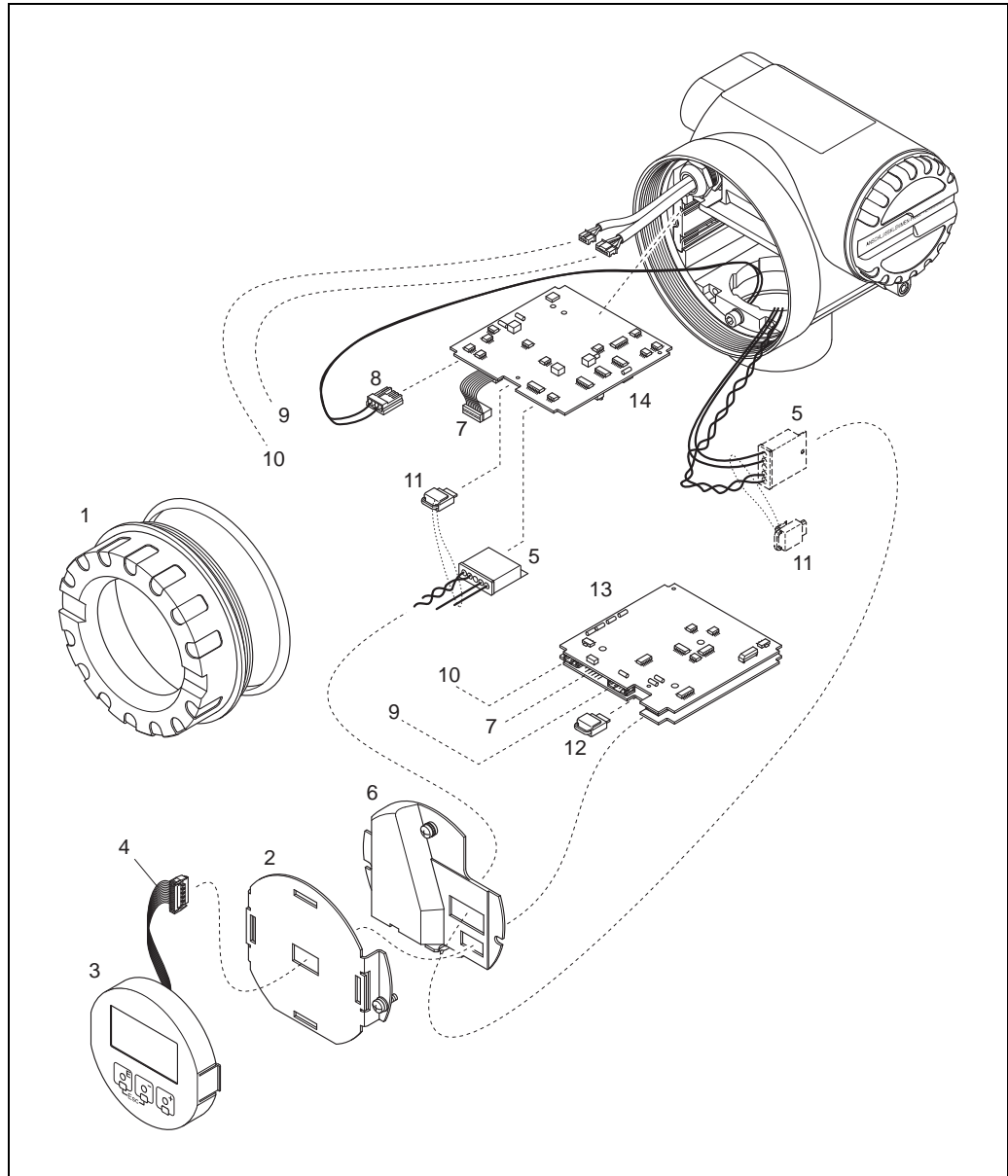

A0009730

Fig. 34: Removing and installing printed circuit board

- 1 Cover of the electronics compartment
- 2 Mounting plate display module (2 screws)
- 3 Display module
- 4 Ribbon cable (display module)
- 5 Electrode signal cable (sensor)
- 6 Cover of electronics compartment (1 screw)
- 7 Connecting cable, printed circuit boards
- 8 Coil current cable (sensor)
- 9 Service cable
- 10 Cable for feed / output signals
- 11 S-DAT (sensor data memory)
- 12 T-DAT (transmitter data memory)
- 13 I/O board
- 14 Amplifier board

## 9.7 Return



### Caution!

Do not return a measuring device if you are not absolutely certain that all traces of hazardous substances have been removed, e.g. substances which have penetrated crevices or diffused through plastic.

Costs incurred for waste disposal and injury (burns, etc.) due to inadequate cleaning will be charged to the owner-operator.

The following steps must be taken before returning a flow measuring device to Endress+Hauser, e.g. for repair or calibration:

- Always enclose a duly completed "Declaration of contamination" form. Only then can Endress+Hauser transport, examine and repair a returned device.
- Enclose special handling instructions if necessary, for example a safety data sheet as per EC REACH Regulation No. 1907/2006.
- Remove all residues. Pay special attention to the grooves for seals and crevices which could contain residues. This is particularly important if the substance is hazardous to health, e.g. flammable, toxic, caustic, carcinogenic, etc.



### Note!

You will find a preprinted "Declaration of contamination" form at the back of these Operating Instructions.

## 9.8 Disposal

Please observe the regulations applicable in your country or region.

## 9.9 Software history

Date	Software-Version	Changes to software	Documentation
05.2009	Device software: V 2.02.XX	Software expansion: ■ Functional adaptations	71111263 / 13.10
02.2003	Amplifier: V 2.00.01  Communication module: V 2.02.00 (de/en) V 2.03.00 (fr/it)	Software expansion: ■ Functional adaptations	50097235 / 02.03
04.2001	Amplifier: V 2.00.00  Communication module: V 2.00.00 (de/en) V 2.01.00 (fr/it)	Software expansion: ■ Functional adaptations	
05.2000	Amplifier: V 1.00.01  Communication module: V 1.00.01	Original software.  Compatible with: – FieldTool – Commuwin II (version 2.05.03 and higher) – HART Communicator DXR 375 (from OS 4.6) with Rev. 1, DD 1.	

## 10 Technical data

### 10.1 Technical data at a glance

#### 10.1.1 Application

→ 5

#### 10.1.2 Function and system design

---

Measuring principle      Electromagnetic flow measurement on the basis of Faraday's Law.

---

Measuring system      → 7

#### 10.1.3 Input

---

Measured variable      Flow rate (proportional to induced voltage)

---

Measuring range      Typical  $v = 0.01$  to  $10$  m/s ( $0.033$  to  $33$  ft/s) with the specified measuring accuracy

---

Operable flow range      Over  $1000 : 1$

#### 10.1.4 Output

---

Output signal

##### Current output

Applied direct current  $4$  to  $20$  mA, input from DC voltage source.

- Terminal voltage:  $12$  to  $30$  V DC,  $13.9$  to  $30$  V DC (Ex i)
- Resolution:  $4.4$   $\mu$ A

##### Frequency output

Open collector, passive, galvanically isolated,  $30$  V DC,  $100$  mA ( $250$  mA /  $20$  ms)

Optional configurable as:

- Frequency output:
  - Full scale frequency  $500$  to  $10000$  Hz ( $f_{max} = 12.5$  kHz)
- Pulse output:
  - Pulse value and pulse polarity adjustable, pulse width adjustable ( $0.01$  to  $10$  s), pulse frequency max.  $50$  Hz
- Status output:
  - E.g. for error messages, Empty Pipe Detection, flow direction recognition, limit value configurable

##### Ex i version

- Power supply, signal circuits and pulse/frequency output with "intrinsically safe" protection rating, EExialIC and EExialIB, only for connection to certified, intrinsically safe circuits with the following maximum values:
  - $U_i = 30$  V,  $I_i = 150$  mA,  $P_i = 810$  mW
  - Effective internal inductance: negligible
  - Effective internal capacitance:  $C_i \leq 25$  nF
- Pulse output:
  - Maximum values:  $U_i = 30$  V,  $I_i = 10$  mA,  $P_i = 1$  W
  - Effective internal inductance: negligible
  - Effective internal capacitance: negligible

Signal on alarm *Current output:*  
 Failsafe mode selectable (e.g. according to NAMUR recommendation NE 43) → 55

*Pulse / frequency output:*  
 Failsafe mode selectable → 55

*Relay output:*  
 "de-energized" in the event of a fault or power supply failure

Load The load is calculated as follows:

Non Ex area	$R_L[\Omega] = \frac{U_s [V] - U_v [V]}{I_M [A]} = \frac{U_s [V] - 12 [V]}{0.022 [A]}$	A001.3227
Ex area	$R_L[\Omega] = \frac{U_s [V] - U_v [V]}{I_M [A]} = \frac{U_s [V] - 13.9 [V]}{0.022 [A]}$	A001.3228

- $R_L [\Omega]$  = max. load resistance, load (cable resistance)
- $U_s [V]$  = external supply voltage of 12 to 30 V DC (outgoing supply voltage, transmitter supply unit)
- $U_v [V]$  = min. supply voltage of 12 V DC (13.9 V DC with Ex-i) (required supply voltage, transmitter)
- $I_M [A]$  = max. signal transmission current (failsafe mode current output: 22 mA max. current)

The minimum load resistance ( $R_L$ ) necessary for a data transfer via HART protocol by way of the current signal cable is 250  $\Omega$ . The minimum external supply voltage ( $U_s$ ) therefore has to be 17.5 V DC (non Ex).

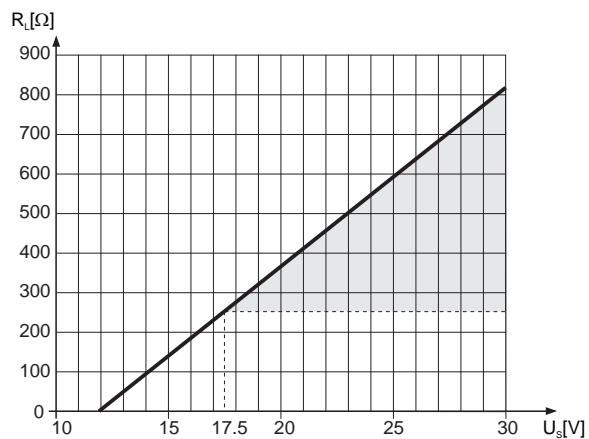

Fig. 35: Load at the analog current output (non Ex)

- $R_L$  max. load resistance (with HART: min. 250  $\Omega$ )
- $U_s$  external supply voltage (non Ex)

Low flow cut off Switch points for low flow cut off freely selectable.

Galvanic isolation All circuits for inputs, outputs and power supply are galvanically isolated from each other.

---

### 10.1.5 Power supply

---

Electrical connections →  27

---

Supply voltage (power supply) Non Ex area:

- 12 to 30 V DC
- 17.5 to 30 V DC (HART)

Ex area (Ex i):

- 13.9 to 30 V DC
- 19.4 to 30 V DC (HART)

---

Cable entries Power supply and signal cable (inputs/outputs):

- Cable entry M20 × 1.5 (8 to 12 mm / 0.31 to 0.47 in)
- Thread for cable entries ½" NPT, G ½"

---

Cable specifications Use shielded cables.

---

Power supply failure Lasting min. 1 power cycle:

- T-DAT™ saves measuring system data if power supply fails
- S-DAT™: exchangeable data storage device which stores sensor characteristic data (nominal diameter, serial number, calibration factor, zero point, etc.)

---

Potential equalization →  29

### 10.1.6 Performance characteristics

Reference operating conditions

To DIN EN 29104 and VDI/VDE 2641:

- Fluid temperature:  $+28\text{ °C} \pm 2\text{ K}$
- Ambient temperature:  $+22\text{ °C} \pm 2\text{ K}$
- Warm-up time: 30 minutes

Installation:

- Inlet run  $>10 \times \text{DN}$
- Outlet run  $> 5 \times \text{DN}$
- Sensor and transmitter grounded.
- Sensor centered relative to the pipe.

Maximum measured error

Pulse output:  $\pm 0.5\%$  o.r.  $\pm 4\text{ mm/s}$  (o.r. = of reading)

Supply-voltage fluctuations have no effect within the specified range.

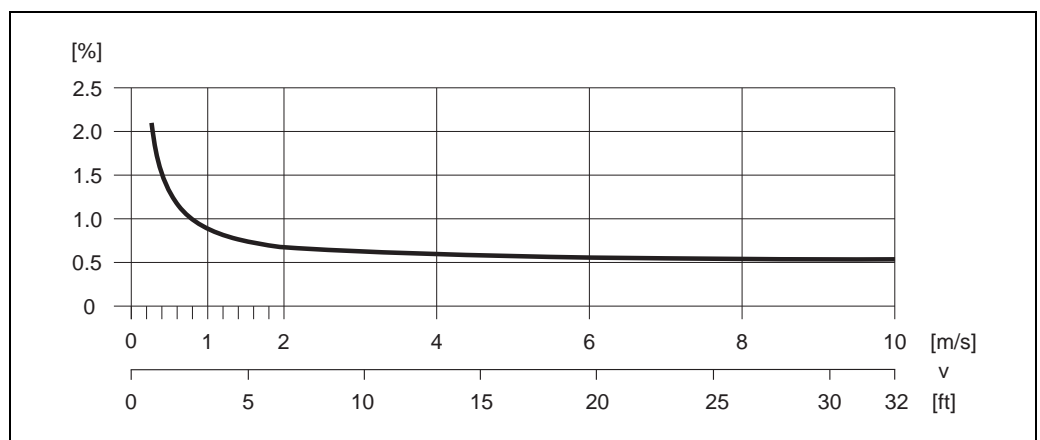

Fig. 36: Max. measured error in % of reading

Repeatability

max.  $\pm 0.25\%$  o.r.  $\pm 2\text{ mm/s}$  (o.r. = of reading)

### 10.1.7 Operating conditions: Installation

Installation instructions

Any orientation (vertical, horizontal), restrictions and additional installation instructions → [12](#)

Inlet and outlet runs

If possible, install the sensor upstream from fittings such as valves, T-pieces, elbows, etc.

The following inlet and outlet runs must be observed in order to meet accuracy specifications







(→ [63](#), → [15](#)):

- Inlet run:  $\geq 5 \times \text{DN}$
- Outlet run:  $\geq 2 \times \text{DN}$

Adapters

→ [16](#)

### 10.1.8 Operating conditions: Environment

Ambient temperature range	<ul style="list-style-type: none"> <li>■ Transmitter: -20 to +60 °C (-4 to +140 °F)</li> </ul> <p> Note!</p> <ul style="list-style-type: none"> <li>- At ambient temperatures below -20 °C (-4 °F), the readability of the display may be impaired.</li> <li>- Install the device at a shady location. Avoid direct sunlight, particularly in warm climatic regions.</li> </ul> <ul style="list-style-type: none"> <li>■ Sensor:</li> <li>- Flange material carbon steel: -10 to +60 °C (+14 to +140 °F)</li> <li>- Flange material stainless steel: -40 to +60 °C (-40 to +140 °F)</li> </ul> <p> Caution!</p> <p>Do not exceed the min. and max. temperatures for the lining of the measuring tube (→  65, "Medium temperature range").</p>
Storage temperature	<p>The storage temperature corresponds to the operating temperature range of the transmitter and sensor.</p> <p> Caution!</p> <ul style="list-style-type: none"> <li>■ The measuring device must be protected against direct sunlight during storage in order to avoid unacceptably high surface temperatures.</li> <li>■ Choose a storage location where moisture does not collect in the measuring device. This will help prevent fungus and bacteria infestation which can damage the lining.</li> </ul>
Degree of protection	IP 67 (NEMA 4X) for transmitter and sensor
Shock and vibration resistance	Acceleration up to 2 g in accordance with IEC 600 68-2-6
CIP cleaning	<p>CIP cleaning possible:</p> <p> Caution!</p> <p>The maximum fluid temperature permitted for the measuring device must not be exceeded.</p>
SIP cleaning	<p>SIP cleaning possible: Promag H, Promag P (with PFA lining)</p> <p> Caution!</p> <p>The maximum fluid temperature permitted for the measuring device must not be exceeded.</p>
Electromagnetic compatibility (EMC)	<ul style="list-style-type: none"> <li>■ As per IEC/EN 61326 and NAMUR Recommendation NE 21</li> <li>■ Emission: to limit value for industry EN 55011</li> </ul>



### 10.1.9 Operating conditions: Process

Medium temperature range The permitted temperature depends on the lining of the measuring tube:

*Promag P*

Standard

- -40 to +130 °C (-40 to +266 °F) for PTFE restrictions → see diagram below
- -20 to +150 °C (-4 to +302 °F) for PFA restrictions → see diagram below

Optional

High-temperature version (HT): -20 to +180 °C (-4 to +356 °F) for PFA

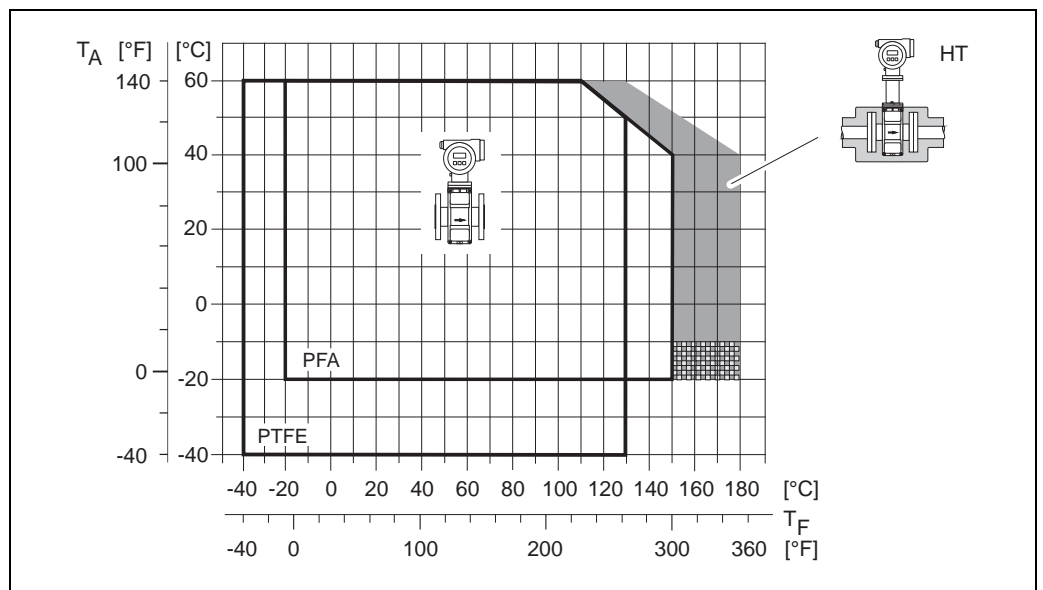

Fig. 37: Promag P compact version (with PFA or PTFE lining)

T<sub>A</sub> = ambient temperature; T<sub>F</sub> = fluid temperature; HT = high-temperature version with insulation

*Promag H*

Sensor:

-20 to +150 °C (-4 to +302 °F)

Seals:

EPDM, Viton, Kalrez, Silicone: -20 to +150 °C (-4 to +302 °F)

Conductivity of the fluid The minimum conductivity is ≥ 50 µS/cm

Medium pressure range  
(nominal pressure)

*Promag P*

- EN 1092-1 (DIN 2501)
  - PN 10 (DN 200)
  - PN 16 (DN 65 to 200)
  - PN 25 (DN 200)
  - PN 40 (DN 25 to 150)
- ANSI B 16.5
  - Class 150 (1 to 8")
  - Class 300 (1 to 6")
- JIS B2220
  - 10 K (DN 50 to 200)
  - 20 K (DN 25 to 200)

*Promag H*

The permitted nominal pressure depends on the process connection and the seal:

- 40 bar → flange, weld nipple (with O-ring seal)
- 16 bar → all other process connections

Pressure tightness  
Measuring tube lining

*Promag P*

*Measuring tube lining: PTFE*

Promag P nominal diameter		Resistance of measuring tube lining to partial vacuum: limit values for absolute pressure [mbar] ([psi]) at various fluid temperatures					
[mm]	[inch]	25 °C	80 °C	100 °C	130 °C	150 °C	180 °C
		77 °F	176 °F	212 °F	266 °F	302 °F	356 °F
15	½"	0	0	0	100 (1.45)	–	–
25	1"	0	0	0	100 (1.45)	–	–
32	–	0	0	0	100 (1.45)	–	–
40	1½"	0	0	0	100 (1.45)	–	–
50	2"	0	0	0	100 (1.45)	–	–
65	–	0	*	40 (0.58)	130 (1.89)	–	–
80	3"	0	*	40 (0.58)	130 (1.89)	–	–
100	4"	0	*	135 (1.96)	170 (2.47)	–	–
125	–	135 (1.96)	*	240 (3.48)	385 (5.58)	–	–
150	6"	135 (1.96)	*	240 (3.48)	385 (5.58)	–	–
200	8"	200 (2.90)	*	290 (4.21)	410 (5.95)	–	–

\* No value can be quoted.

*Promag P*

*Measuring tube lining: PFA*

Promag P nominal diameter		Resistance of measuring tube lining to partial vacuum: limit values for absolute pressure [mbar] ([psi]) at various fluid temperatures					
[mm]	[inch]	25 °C	80 °C	100 °C	130 °C	150 °C	180 °C
		77 °F	176 °F	212 °F	266 °F	302 °F	356 °F
25	1"	0	0	0	0	0	0
32	–	0	0	0	0	0	0
40	1½"	0	0	0	0	0	0
50	2"	0	0	0	0	0	0
65	–	0	*	0	0	0	0
80	3"	0	*	0	0	0	0
100	4"	0	*	0	0	0	0
125	–	0	*	0	0	0	0
150	6"	0	*	0	0	0	0
200	8"	0	*	0	0	0	0

\* No value can be quoted.

*Promag H*  
*Measuring tube lining: PFA*

Promag H nominal diameter		Pressure tightness, measuring tube lining: limit values for absolute pressure [mbar] ([psi]) at various fluid temperature					
[mm]	[inch]	25 °C	80 °C	100 °C	130 °C	150 °C	180 °C
		77 °F	176 °F	212 °F	266 °F	302 °F	356 °F
2 to 100	1/12 to 4"	0	0	0	0	0	0

Limiting flow

→  17

Pressure loss

- No pressure loss if the sensor is installed in piping with the same nominal diameter (for Promag H only from DN 8).
- Pressure losses for configurations incorporating adapters according to DIN EN 545 →  16.

### 10.1.10 Mechanical construction

Design, dimensions

The dimensions and face-to-face length of the sensor and transmitter can be found in the separate "Technical Information" documentation for each device which can be downloaded in PDF format from [www.endress.com](http://www.endress.com). A list of available "Technical Information" documentation can be found in the "Documentation" section →  73.

Weight (SI units)



*Promag P*

Note!

The following weights apply to standard pressure ratings and without packaging material.

Weights in kg for the Promag P						
Nominal diameter		EN (DIN)	Compact version		ANSI	
[mm]	[inch]		JIS			
25	1"	6.8	6.8	Class 150	6.8	
32	1¼"	7.5	7.5		–	
40	1½"	8.9	8.9		8.9	
50	2"	10.1	10.1		10.1	
65	2½"	11.5	11.5		–	
80	3"	13.5	13.5		13.5	
100	4"	15.5	15.5		15.5	
125	5"	21.0	21.0		–	
150	6"	25.0	25.0		25.0	
200	8"	44.5	44.5		44.5	

Transmitter Promag (compact version): 2.9 kg  
 High temperature version: +1.5 kg  
 (Weights apply to standard pressure ratings and without packaging material)

*Promag H*

Weights in kg for the Promag H		
Nominal diameter		Compact version
[mm]	[inch]	DIN
2	1/12"	4.7
4	5/32"	4.7
8	5/16"	4.8
15	½"	4.9
25	1"	5.0
40	1½"	6.0
50	2"	8.5
65	2½"	9.0
80	3"	18.5
100	4"	18.0

Transmitter Promag (compact version): 2.9 kg  
 (Weights apply to standard pressure ratings and without packaging material)

Weight (US units)

*Promag P*

Weights in lbs for the Promag P							
Nominal diameter			EN (DIN)	Compact version		ANSI	
[mm]	[inch]			JIS			
25	1"	PN 40	15.0	20K	15.0	Class 150	15.0
32	1¼"		16.5		16.5		–
40	1½"		19.6		19.6		19.6
50	2"		22.3		22.3		22.3
65	2½"	PN 16	25.4	10K	25.4		–
80	3"		29.8		29.8		29.8
100	4"		34.2		34.2		34.2
125	5"		46.3		46.3		–
150	6"	PN 10	55.1		55.1		55.1
200	8"		98.1		98.1		98.1

Transmitter Promag (compact version): 6.4 lbs  
 High temperature version: +3.3 lbs  
 (Weights apply to standard pressure ratings and without packaging material)

*Promag H*

Weights in lbs for the Promag H			
Nominal diameter		Compact version	
[mm]	[inch]	DIN	
2	1/12"	10.4	
4	5/32"	10.4	
8	5/16"	10.6	
15	½"	10.8	
25	1"	11.0	
40	1½"	13.2	
50	2"	18.7	
65	2½"	19.8	
80	3"	40.8	
100	4"	39.7	

Transmitter Promag (compact version): 6.4 lbs  
 (Weights apply to standard pressure ratings and without packaging material)

Material	<p><i>Promag P</i></p> <ul style="list-style-type: none"> <li>■ Transmitter housing: powder-coated die-cast aluminum</li> <li>■ Sensor housing: powder-coated die-cast aluminum</li> <li>■ Measuring tube: stainless steel 1.4301 or 1.4306/304L (for flanges made of carbon steel with Al/Zn protective coating)</li> <li>■ Electrodes: 1.4435; Alloy C-22; tantalum; platinum</li> <li>■ Flanges             <ul style="list-style-type: none"> <li>– EN 1092-1 (DIN2501): RSt37-2 (S235JRG2) / C22 / FE 410W B (with Al/Zn protective coating)</li> <li>– ANSI: A105 / F316L (with Al/Zn protective coating)</li> <li>– JIS: RSt37-2 (S235JRG2) / HII / 1.0425/316L (with Al/Zn protective coating)</li> </ul> </li> <li>■ Seals: as per DIN EN 1514-1</li> <li>■ Ground disks: 1.4435/316L, Alloy C-22, titanium, tantalum</li> </ul> <p><i>Promag H</i></p> <ul style="list-style-type: none"> <li>■ Transmitter housing:             <ul style="list-style-type: none"> <li>– Compact housing: powder-coated die-cast aluminum</li> </ul> </li> <li>■ Sensor housing: stainless steel 1.4301</li> <li>■ Wall mounting kit: stainless steel 1.4301</li> <li>■ Measuring tube: stainless steel 1.4301</li> <li>■ Lining material: PFA (USP Class VI; FDA 21 CFR 177.1550; 3A)</li> <li>■ Electrodes:             <ul style="list-style-type: none"> <li>– Standard: 1.4435</li> <li>– Optional: Alloy C-22, tantalum, platinum (only up to DN 25 (1"))</li> </ul> </li> <li>■ Flanges:             <ul style="list-style-type: none"> <li>– Connection generally made of stainless steel 1.4404/316L</li> <li>– EN (DIN), ANSI, JIS also in PVDF</li> <li>– Adhesive fitting made of PVC</li> </ul> </li> <li>■ Seals:             <ul style="list-style-type: none"> <li>– DN 2 to 25 (1/12 to 1"): O-ring (EPDM, Viton, Kalrez), molded seal (EPDM*, Viton, Silicone*)</li> <li>– DN 40 to 100 (1½ to 4"): molded seal (EPDM*, Silicone*)</li> <li>* = USP Class VI; FDA 21 CFR 177.2600; 3A</li> </ul> </li> <li>■ Grounding rings: 1.4435/316L (optional: tantalum, Alloy C-22)</li> </ul>
----------	--

Material load diagrams	Material load diagrams (pressure-temperature diagrams) for the process connections can be found in the separate "Technical Information" documentation → 73, "Documentation".
------------------------	--

Fitted electrodes	<p><i>Promag P</i></p> <ul style="list-style-type: none"> <li>■ 2 measuring electrodes for signal detection</li> <li>■ 1 EPD electrode for empty pipe detection</li> <li>■ 1 Reference electrode for potential equalization</li> </ul> <p><i>Promag H</i></p> <ul style="list-style-type: none"> <li>■ 2 measuring electrodes for signal detection</li> <li>■ 1 EPD electrode for empty pipe detection, not for DN 2 to 15 (1/12 to ½")</li> </ul>
-------------------	--

Process connection	<p><i>Promag P</i></p> <p>Flange connections:</p> <ul style="list-style-type: none"> <li>■ EN 1092-1 (DIN 2501) form A DN 65 PN 16 exclusively according to EN 1092-1 (not as per DIN 2501)</li> <li>■ ANSI</li> <li>■ JIS</li> </ul> <p><i>Promag H</i></p> <p>With O-ring:</p> <ul style="list-style-type: none"> <li>■ Weld nipple DIN (EN), ISO 1127, ODT/SMS</li> <li>■ Flange EN (DIN), ANSI, JIS</li> <li>■ Flange made of PVDF EN (DIN), ANSI, JIS</li> <li>■ External thread</li> <li>■ Internal thread</li> <li>■ Hose connection</li> <li>■ PVC adhesive fitting</li> </ul> <p>With molded seal:</p> <ul style="list-style-type: none"> <li>■ Weld nipple DIN 11850, ODT/SMS</li> <li>■ Clamp ISO 2852, DIN 32676, L14 AM7</li> <li>■ Coupling DIN 11851, DIN 11864-1, ISO 2853, SMS 1145</li> <li>■ Flange DIN 11864-2</li> </ul>
--------------------	---

Surface roughness	<p>All data relate to parts in contact with fluid.</p> <ul style="list-style-type: none"> <li>■ Liner → PFA: <math>\leq 0.4 \mu\text{m}</math> (15 <math>\mu\text{in}</math>)</li> <li>■ Electrodes → 1.4435, Alloy C-22: 0.3 to 0.5 <math>\mu\text{m}</math> (12 to 20 <math>\mu\text{in}</math>)</li> <li>■ Process connection made of stainless-steel (Promag H): <math>\leq 0.8 \mu\text{m}</math> (31 <math>\mu\text{in}</math>)</li> </ul>
-------------------	--

### 10.1.11 Human interface

Display elements	<ul style="list-style-type: none"> <li>■ Liquid crystal display: four lines with 16 characters per line</li> <li>■ Custom configurations for presenting different measured values and status variables</li> <li>■ 2 totalizers</li> </ul> <p> Note! At ambient temperatures below <math>-20 \text{ }^\circ\text{C}</math> (<math>-4 \text{ }^\circ\text{F}</math>), the readability of the display may be impaired.</p>
Operating elements	<ul style="list-style-type: none"> <li>■ Onsite operation with three optical sensor keys (<math>\square/\square/\square</math>)</li> </ul>
Remote operation	Operation by means of HART protocol and FieldCare

### 10.1.12 Certificates and approvals

CE mark	The measuring system complies with the legal requirements of the EU directives. Endress+Hauser confirms that the device has been tested successfully by affixing the CE mark to it.
C-tick mark	The measuring system is in conformity with the EMC requirements of the "Australian Communications and Media Authority (ACMA)".
Ex approval	Information about currently available Ex versions (ATEX, FM, CSA, etc.) can be supplied by your Endress+Hauser Sales Center on request. All explosion protection data are given in a separate documentation which is available upon request.
Sanitary compatibility	<p><i>Promag H</i></p> <ul style="list-style-type: none"> <li>■ 3A-approval and EHEDG-tested</li> <li>■ Seals: FDA-compliant (except for Kalrez seals)</li> </ul>
Pressure measuring device approval	<p>The measuring devices can be ordered with or without PED (Pressure Equipment Directive). If a device with PED is required, this must be ordered explicitly. For devices with nominal diameters less than or equal to DN 25 (1"), this is neither possible nor necessary.</p> <ul style="list-style-type: none"> <li>■ With the identification PED/G1/III on the sensor nameplate, Endress+Hauser confirms conformity with the "Basic safety requirements" of Appendix I of the Pressure Equipment Directive 97/23/EC.</li> <li>■ Devices with this identification (with PED) are suitable for the following types of fluid: <ul style="list-style-type: none"> <li>– Fluids of Group 1 and 2 with a steam pressure of greater or less than 0.5 bar (7.3 psi)</li> <li>– Unstable gases</li> </ul> </li> <li>■ Devices without this identification (without PED) are designed and manufactured according to good engineering practice. They correspond to the requirements of Art. 3, Section 3 of the Pressure Equipment Directive 97/23/EC. Their application is illustrated in Diagrams 6 to 9 in Appendix II of the Pressure Equipment Directive 97/23/EC.</li> </ul>
Other standards and guidelines	<ul style="list-style-type: none"> <li>■ EN 60529: Degrees of protection by housing (IP code)</li> <li>■ EN 61010-1 Protection measures for electrical equipment for measurement, control, regulation and laboratory procedures</li> <li>■ IEC/EN 61326 "Emission in accordance with requirements for class A".</li> <li>■ ANSI/ISA-S82.01 Safety Standard for Electrical and Electronic Test, Measuring, Controlling and related Equipment – General Requirements. Pollution degree 2, Installation Category II.</li> <li>■ CAN/CSA-C22.2 (No. 1010.1-92) Safety requirements for Electrical Equipment for Measurement and Control and Laboratory Use. Pollution degree 2, Installation Category I.</li> <li>■ NAMUR NE 21 Electromagnetic compatibility (EMC) of industrial process and laboratory control equipment.</li> <li>■ NAMUR NE 43 Standardization of the signal level for the breakdown information of digital transmitters with analog output signal.</li> </ul>



### 10.1.13 Ordering information

The Endress+Hauser service organization can provide detailed information on the order codes on request.

### 10.1.14 Accessories

Various accessories are available for the transmitter and the sensor. These can be ordered separately from Endress+Hauser →  47.

For detailed information on specific order codes, please contact the Endress+Hauser service organization.

### 10.1.15 Documentation

- Flow Measurement (FA00005D/06)
- Promag 23P Technical Information (TI00049D/06)
- Promag 23H Technical Information (TI00051D/06)
- Promag 23 Description of Device Functions (BA00050D/06)
- Supplementary documentation on Ex-ratings: ATEX, FM, CSA, etc.

# Index

## A

Accessories.....	47
Adapters (installation of sensors).....	16
Ambient temperature range.....	64
Applicator (selection and configuration software).....	49
Approvals.....	9

## B

Boards	
See Printed circuit boards	

## C

Cable entries	
Degree of protection.....	31
Technical data.....	62
Calibration factor.....	8
CE mark.....	72
CE mark (Declaration of Conformity).....	9
Certificates.....	9
Change parameter / enter numerical values.....	34
CIP cleaning.....	64
Cleaning (exterior cleaning).....	46
Cleaning using pigs, Promag H.....	24
Code entry (function matrix).....	35
Commissioning	
Empty-pipe/Full-pipe adjustment.....	44
CommuBox FXA 195.....	48
CommuBox FXA 195 (electrical connection).....	28
Communication.....	37
Conductivity of fluid.....	65
Connection	
HART.....	28
See Electrical connection	
Control	
Device description files.....	38
Field Xpert HART Communicator.....	38
FieldCare.....	38
C-tick mark.....	9, 72

## D

Data back-up (of device data with T-DAT).....	43
Declaration of Conformity (CE mark).....	9
Degree of protection.....	31, 64
Device description files.....	38
Device designation.....	7
Device functions	
See the "Description of Device Functions" manual	
Display	
Display.....	33
Display and operating elements.....	32
Local display.....	32
See Display	
Turning the display.....	25
Disposal.....	59
Documentation, supplementary.....	73
Down pipes.....	13

## E

Electrical connection	
CommuBox FXA 191.....	28
Degree of protection.....	31
HART handheld terminal.....	28
Post-connection check (checklist).....	31
Potential equalization.....	29
Terminal assignment, transmitter.....	28
Electrodes	
EPD electrode.....	14
Measuring electrode plane.....	14
Reference electrode (potential equalization).....	14
Electronics boards	
See Printed circuit boards	
EMC (electromagnetic compatibility).....	64
Empty pipe detection (EPD)	
EPD electrode.....	14
Empty-pipe/Full-pipe adjustment.....	44
Environment.....	64
Error limits	
See Performance characteristics	
Error messages	
Confirming error messages.....	36
Process error (application error).....	53
System errors (device errors).....	51
Error types (system and process errors).....	36
European Pressure Equipment Directive (PED).....	72
Ex approval.....	72
Exterior cleaning.....	46

## F

Failsafe mode inputs/outputs.....	55
Field Xpert SFX 100.....	48
Field Xpert SFX100.....	28
FieldCare.....	38, 49
Fieldgate FXA320.....	48
Fieldgate FXA520.....	48
Fitted electrodes.....	70
Flow rate/limits.....	17
Function check.....	42
Function descriptions	
See the "Description of Device Functions" manual	
Function matrix (operation).....	34
FXA193.....	49
FXA195.....	48

## G

Galvanic isolation.....	61
Ground cable	
Promag P.....	18
Grounding rings	
Promag H.....	23

**H**

HART	
Command groups	37
Command No.	39
Error messages	39
Field Xpert HART Communicator	38
Write protection, switching on and off	41
Hazardous substances	59
High-temperature version	
Installation	19
Temperature ranges	19
HOME position (operating mode display)	32

**I**

Incoming acceptance	10
Inlet run	15
Input	60
Installation conditions	
Down pipes	13
Inlet and outlet runs	15
Installing pumps	12
Mounting location	12
Orientation (vertical, horizontal)	14
Partially filled pipes	13
Vibrations	15
Installing the sensor	
Adapters	16
High-temperature version	19
Promag H	22
Promag P	18
Insulation of pipes (installing Promag P)	19

**L**

Load (output signal)	61
Local display	
See Display	
Low flow cut off	61

**M**

Maintenance	46
Material	70
Material load diagrams	70
Measured variable	60
Measuring electrodes	
See Electrodes	
Measuring principle	60
Measuring range	60
Measuring system	7, 60
Measuring tube	
Lining, temperature range	65
Measuring tube lining	66
Medium pressure range	66
Medium temperature range	65
Memograph M	49

**N**

Nameplate	
Sensor	8
Transmitter	7
Nominal diameter and flow rate	17

**O**

Operable flow range	60
Operating conditions	63–64
Operating elements	32
Operation	
Display and operating elements	
Function matrix	34
Operational safety	5
Order code	
Accessories	47
Sensor	8
Transmitter	7
Ordering information	73
Outlet runs	15
Output	60

**P**

Performance characteristics	
Maximum measured error	63
Reference operating conditions	63
Pigs (cleaning)	24
Post-installation check (checklist)	26
Power supply	62
Power supply failure	62
Pressure	
Device approval (PED)	72
Pressure loss	
Adapters (reducers, expanders)	16
General information	67
Pressure tightness measuring	66
Printed circuit boards, removing and installing	
Field housing	57
Process connection	71
Process error	
Definition	36
Process error messages	53
Programming mode	
Disable	35
Enable	35
Promag H	
Cleaning using pigs	24
Grounding rings	23
Installation	22
Seals	22
Weld nipple	24
Promag P	
Ground cable	18
High-temperature version	19
Installation	18
Seals	18
Tightening torques	20
Pumps	
Mounting location	12

**Q**

Quick Setup	
Data back-up (of device data with T-DAT)	43
Transfer data	43

**R**

Registered trademarks .....	9
Remote operation .....	71
Repair .....	59
Replacing	
Electronics boards (installing/removing) .....	57
Returning devices .....	59

**S**

Safety icons .....	6
Safety instructions .....	5
Sanitary compatibility .....	72
S-DAT (HistoROM) .....	45
Seals .....	46
Promag H .....	22
Promag P .....	18
Seals (sensor process connection) .....	18
Sensor installation	
See Installing sensor	
Serial number .....	7–8
Service interface FXA193 .....	49
Shock resistance .....	64
Signal on alarm .....	61
SIP cleaning .....	64
Software	
Amplifier display .....	42
Versions (History) .....	59
Spare parts .....	56
Standards, guidelines .....	72
Storage .....	11
Storage temperature .....	64
Supply voltage .....	62
Surface roughness .....	71
System error	
Definition .....	36
System error messages .....	51

**T**

T-DAT (HistoROM)	
Description .....	45
Save/load (data back-up, e.g. for replacing devices) ...	43
Technical data at a glance .....	60
Temperature	
Storage .....	64
Temperature ranges	
Ambient temperature range .....	64
Fluid temperature .....	65
Tightening torques	
Promag P .....	20
Transporting the sensor .....	10
Troubleshooting instructions .....	50

**V**

Vibration resistance .....	64
Vibrations .....	15
Measures to prevent vibrations .....	15
Shock and vibration resistance .....	64

**W**

Weight	
(SI units) .....	68
(US units) .....	69
Weld nipple, Promag H .....	24
Wiring	
See Electrical connection	
Write protection (HART on/off) .....	41

## Declaration of Hazardous Material and De-Contamination Erklärung zur Kontamination und Reinigung

RA No.

Please reference the Return Authorization Number (RA#), obtained from Endress+Hauser, on all paperwork and mark the RA# clearly on the outside of the box. If this procedure is not followed, it may result in the refusal of the package at our facility.  
Bitte geben Sie die von E+H mitgeteilte Rücklieferungsnummer (RA#) auf allen Lieferpapieren an und vermerken Sie diese auch außen auf der Verpackung. Nichtbeachtung dieser Anweisung führt zur Ablehnung ihrer Lieferung.

Because of legal regulations and for the safety of our employees and operating equipment, we need the "Declaration of Hazardous Material and De-Contamination", with your signature, before your order can be handled. Please make absolutely sure to attach it to the outside of the packaging.

Aufgrund der gesetzlichen Vorschriften und zum Schutz unserer Mitarbeiter und Betriebseinrichtungen, benötigen wir die unterschriebene "Erklärung zur Kontamination und Reinigung", bevor Ihr Auftrag bearbeitet werden kann. Bringen Sie diese unbedingt außen an der Verpackung an.

**Type of instrument / sensor**

Geräte-/Sensortyp \_\_\_\_\_

**Serial number**

Seriennummer \_\_\_\_\_

**Used as SIL device in a Safety Instrumented System / Einsatz als SIL Gerät in Schutzeinrichtungen**

**Process data / Prozessdaten**

Temperature / Temperatur \_\_\_\_\_ [°F] \_\_\_\_\_ [°C] Pressure / Druck \_\_\_\_\_ [psi] \_\_\_\_\_ [ Pa ]  
Conductivity / Leitfähigkeit \_\_\_\_\_ [µS/cm] Viscosity / Viskosität \_\_\_\_\_ [cp] \_\_\_\_\_ [mm<sup>2</sup>/s]

**Medium and warnings**

Warnhinweise zum Medium



	Medium / concentration Medium / Konzentration	Identification CAS No.	flammable entzündlich	toxic giftig	corrosive ätzend	harmful/ irritant gesundheitsschädlich/ reizend	other * sonstiges*	harmless unbedenklich
Process medium Medium im Prozess								
Medium for process cleaning Medium zur Prozessreinigung								
Returned part cleaned with Medium zur Endreinigung								

\* explosive; oxidising; dangerous for the environment; biological risk; radioactive  
\* explosiv; brandfördernd; umweltgefährlich; biogefährlich; radioaktiv

Please tick should one of the above be applicable, include safety data sheet and, if necessary, special handling instructions.

Zutreffendes ankreuzen; trifft einer der Warnhinweise zu, Sicherheitsdatenblatt und ggf. spezielle Handhabungsvorschriften beilegen.

**Description of failure / Fehlerbeschreibung** \_\_\_\_\_

**Company data / Angaben zum Absender**

Company / Firma _____	Phone number of contact person / Telefon-Nr. Ansprechpartner: _____
Address / Adresse _____	Fax / E-Mail _____
_____	Your order No. / Ihre Auftragsnr. _____

"We hereby certify that this declaration is filled out truthfully and completely to the best of our knowledge. We further certify that the returned parts have been carefully cleaned. To the best of our knowledge they are free of any residues in dangerous quantities."

"Wir bestätigen, die vorliegende Erklärung nach unserem besten Wissen wahrheitsgetreu und vollständig ausgefüllt zu haben. Wir bestätigen weiter, dass die zurückgesandten Teile sorgfältig gereinigt wurden und nach unserem besten Wissen frei von Rückständen in gefahrbringender Menge sind."

\_\_\_\_\_  
(place, date / Ort, Datum)

\_\_\_\_\_  
Name, dept./Abt. (please print / bitte Druckschrift)

\_\_\_\_\_  
Signature / Unterschrift

[www.endress.com/worldwide](http://www.endress.com/worldwide)

---

**Endress+Hauser**   
People for Process Automation

---