



Level



Pressure



Flow



Temperature



Liquid
Analysis



Registration



Systems
Components



Services



Solutions

Operating Instructions

Furnace conditioning station for CA72TOC

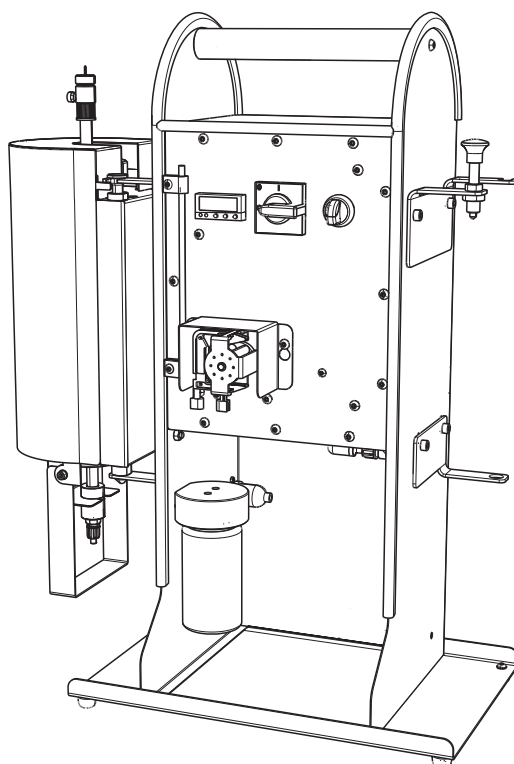

Table of contents

1	Safety instructions	4
1.1	Designated use	4
1.2	Installation, commissioning and operation	4
1.3	Operational safety	4
1.4	Return	4
1.5	Notes on safety icons and symbols	5
2	Identification	6
2.1	Nameplate	6
2.2	Scope of delivery	6
2.3	Certificates and approvals	6
3	Installation	7
3.1	Incoming acceptance, transport, storage	7
3.2	Setting up the station	7
4	Wiring	8
4.1	Electrical connection	8
5	Operation	9
5.1	Overview	9
5.2	Exchanging the furnace	10
5.3	Cleaning the furnace	13
6	Maintenance	15
6.1	Cleaning the furnace conditioning station	15
6.2	Replacing the air filter and pump hose	15
7	Spare parts	17
8	Technical Data	18
8.1	Power supply	18
8.2	Environment	18
8.3	Mechanical construction	18
	Index	19

1 Safety instructions

1.1 Designated use

The conditioning station is designed for the maintenance of the reactors of the CA72TOC analyzer. The device is designed as a benchtop unit. To reduce the risk associated with working with hot component parts, it is recommended to set up the furnace conditioning station close to the analyzer.

Any other use than the one described here compromises the safety of persons and the entire measuring system and is not permitted.

The manufacturer is not liable for damage caused by improper or non-designated use.

1.2 Installation, commissioning and operation

Please note the following:

- Installation, commissioning, operation and maintenance of the furnace conditioning station must only be carried out by trained technical personnel.
This technical personnel must be authorized for the specified activities by the system operator.
- The technical personnel must have read and understood these Operating Instructions and must follow the instructions they contain.
- Before commissioning the furnace conditioning station, make sure all the connections are correct. Ensure that hose connections are not damaged.
- Do not operate damaged products, and secure them against unintentional commissioning. Mark the damaged product as defective.
- Malfunctions at the furnace conditioning station may only be rectified by authorized and specially trained personnel.
- If malfunctions cannot be rectified, the products must be taken out of service and secured against unintentional commissioning.
- Repairs not described in these Operating Instructions may only be carried out at the manufacturer's or by the Service Organization.

1.3 Operational safety

The analyzer has been designed and tested to the highest standards and left the factory in perfect functioning order.

Relevant regulations and European standards have been met.

As the user, you are responsible for complying with the following safety conditions:

- Installation instructions
- Local prevailing standards and regulations.

Electromagnetic compatibility

With regard to electromagnetic compatibility, this device has been tested in accordance with the applicable European standards for industrial applications.

The electromagnetic compatibility indicated only applies to a device that has been connected in accordance with the instructions in these Operating Instructions.

1.4 Return

Please contact your sales center if the device has to be repaired.

If returning the conditioning station, please send it to your sales center.

Use the original packaging to return the device.

1.5 Notes on safety icons and symbols



Warning!

This symbol alerts you to hazards that can cause serious damage to the instrument or to persons if ignored.



Caution!

This symbol alerts you to possible faults which could arise from incorrect operation. They could cause damage to the instrument if ignored.



Note!

This symbol indicates important items of information.

2 Identification

2.1 Nameplate

Compare the order code indicated on the nameplate with the ordering structure and your order.

The nameplate bears the following information:

- Manufacturer data
- Order code (device version)
- Serial number
- Power supply
- Degree of protection
- (Permitted) ambient conditions

2.2 Scope of delivery

The delivery includes:

- Furnace conditioning station
- Adapter for furnace versions with a heatable salt trap
- Set of Operating Instructions, English

If you have any questions, please contact your supplier or your local sales center.

2.3 Certificates and approvals

Declaration of conformity

The product meets the requirements of the harmonized European standards. It thus complies with the legal requirements of the EC directives.

The manufacturer confirms successful testing of the product by affixing the **CE** symbol.

3 Installation

3.1 Incoming acceptance, transport, storage

- Make sure the packaging is undamaged!
Inform the supplier about any damage to the packaging.
Keep the damaged packaging until the matter has been settled.
- Make sure the contents are undamaged!
Inform the supplier about damage to the contents. Keep the damaged products until the matter has been settled.
- Check that the order is complete and agrees with your shipping documents.
- The packaging material used to store or to transport the product must provide shock protection and humidity protection. The original packaging offers the best protection. Also, keep to the approved ambient conditions (see "Technical data").
- If you have any questions, please contact your supplier or your local sales center.

3.2 Setting up the station

Set up the furnace conditioning station securely on a suitable horizontal surface (bench).



Note!

To reduce the risk associated with working with hot component parts, it is recommended to set up the furnace conditioning station close to the analyzer.

Carry the furnace conditioning station by its handle only!

4 Wiring

4.1 Electrical connection



Warnung!

Before connecting the device, make sure that the line voltage matches the voltage indicated on the nameplate.

The following versions are available:

- 115 V AC 50/60 Hz
- 230 V AC 50/60 Hz

The conditioning station is connected to the supply voltage via the power cable with a safety plug with a grounding contact.

If necessary, connect a safety plug that is commonly used in your country to the power cable.



Warnung!

Ensure that the analyzer is sufficiently grounded via the mains connection.

If these conditions cannot be ensured, the device must be grounded on site.

Wiring diagram

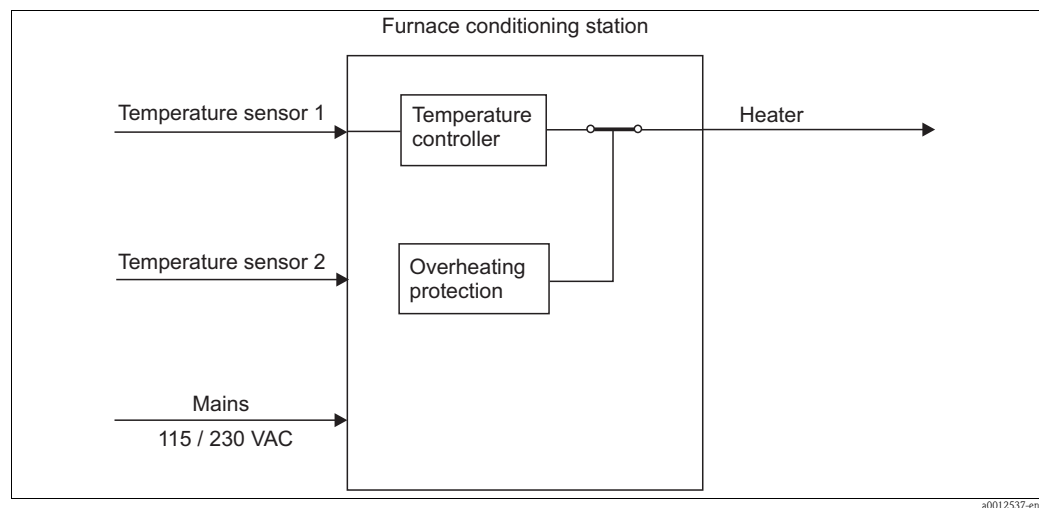

Fig. 1: Wiring diagram



Note!

Temperature sensor 1 is used as the sensor for temperature regulation, and temperature sensor 2 as the sensor to protect the device against overheating (if the temperature regulation system fails). Since both sensors are fitted at the same point, it does not make any difference if the connecting plugs are accidentally swapped.

5 Operation

5.1 Overview

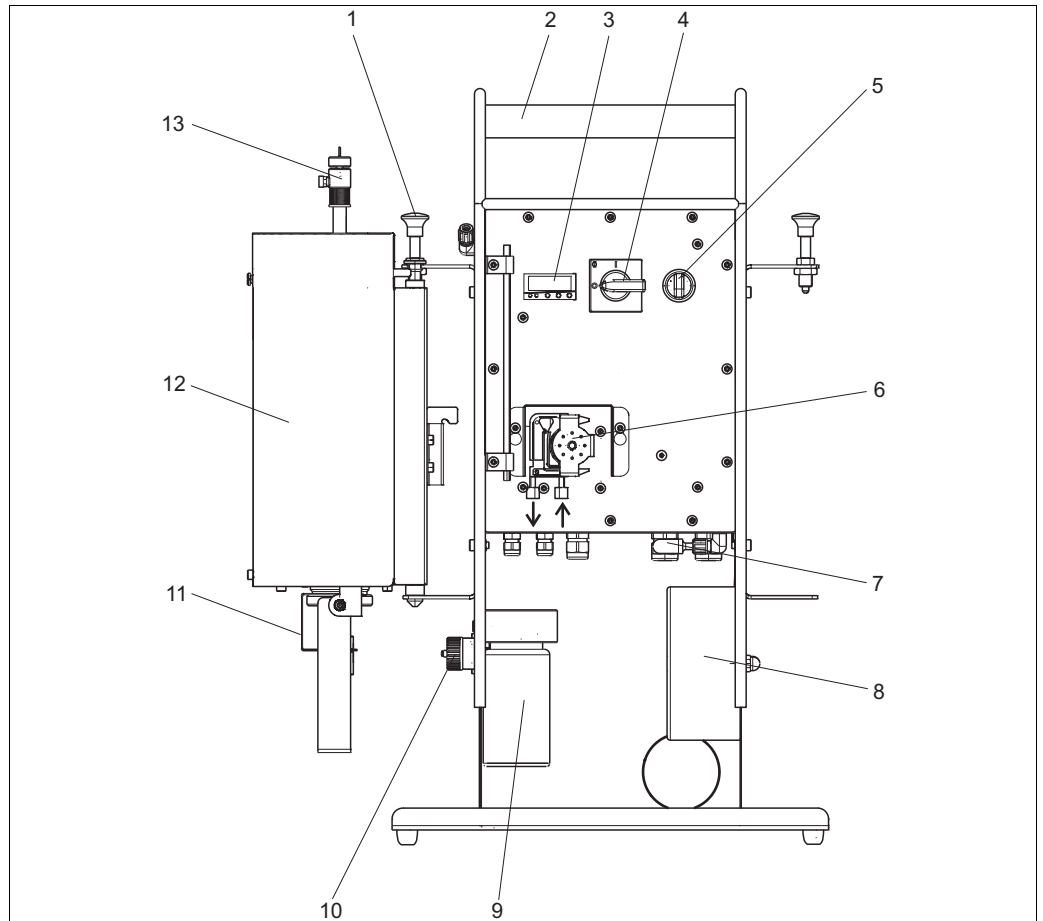

Fig. 2: Overview

1	Lock	8	Transformer (115 V version)
2	Handle	9	Container for medium/condensate
3	Temperature display and control unit	10	Plug-in connection for heater
4	Main switch	11	Adapter with bracket
5	Heating switch	12	Furnace
6	Pump	13	Dosing head
7	Air filter		

The container for medium/condensate (item 9) is filled with deionized water.

5.2 Exchanging the furnace

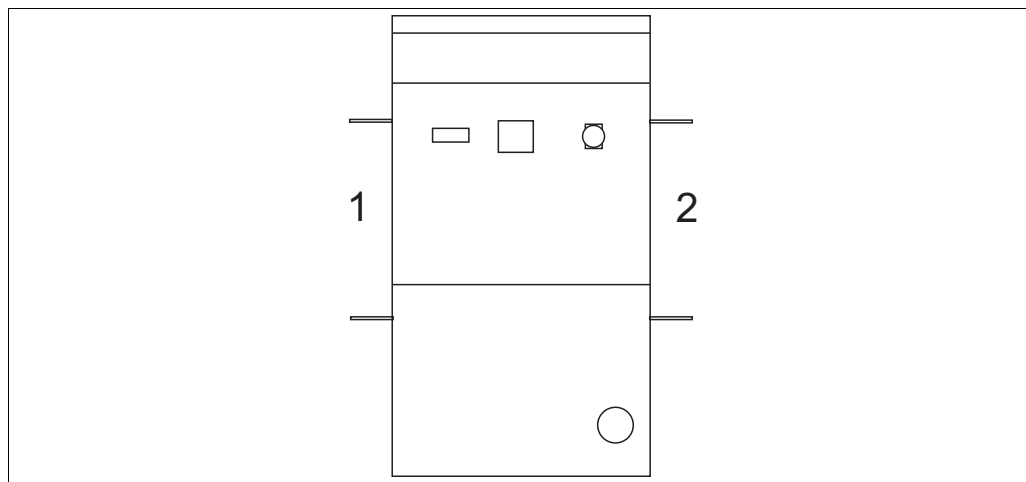

Fig. 3: Maintenance and exchange position

- 1 Maintenance position
2 Exchange position



Warning!

Hot furnaces may cause injury or fire.

- Use heat-resistant gloves.

The heat-resistant gloves must be suitable for a contact temperature of at least 150 °C (300 °F).

- Make sure that no fire hazard is posed by oxidizing material in the vicinity of the conditioning station!
- Make sure that no water is splashed or sprayed onto the hot furnace (steam can cause scalding)!

Prerequisite:

The new furnace (the conditioned furnace) is in the maintenance position (item 1) and is heated. The exchange position (item 2) is empty.

The furnace is exchanged in three steps:

1. The used furnace is removed from the analyzer and placed in the exchange position on the conditioning station.
2. The new furnace is detached from the furnace conditioning station and installed in the analyzer.
3. The used furnace is moved from the exchange position to the maintenance position on the furnace conditioning station.

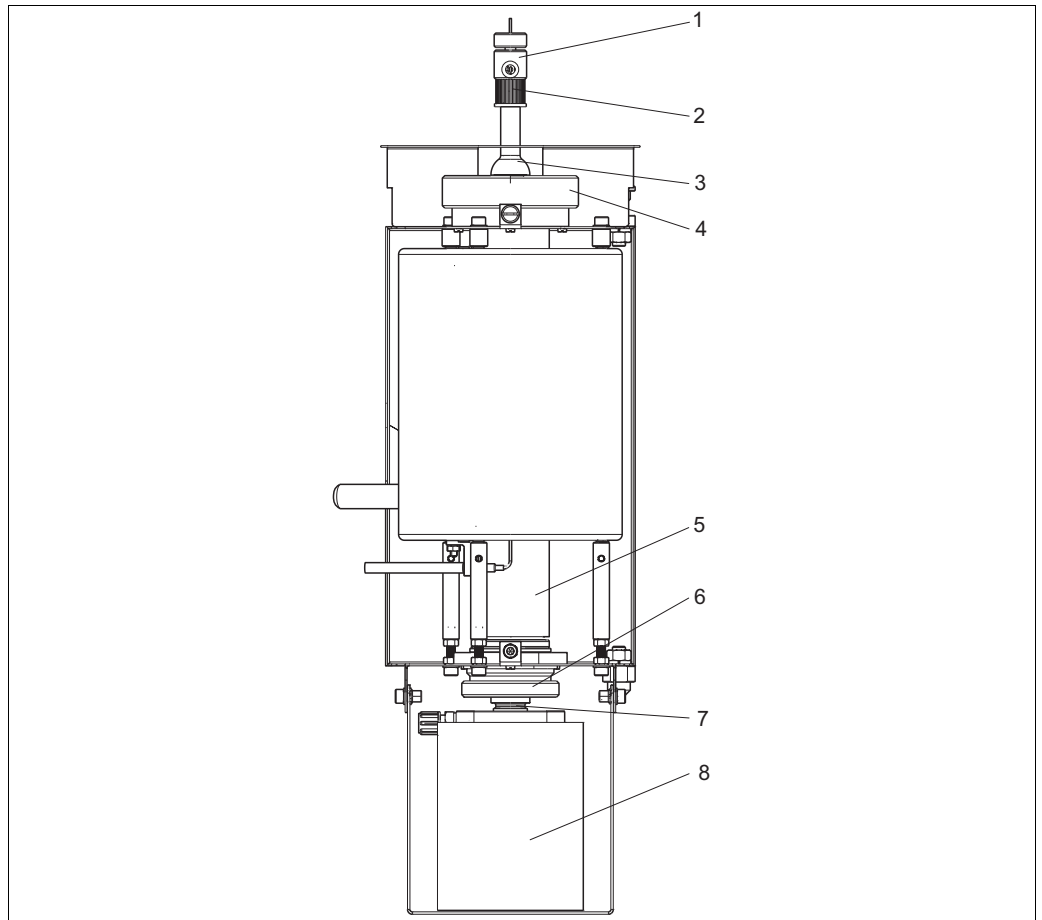

Fig. 4: Furnace

1	Injection unit	5	Glass insert
2	Red cap	6	Knurled head screw
3	Furnace cover	7	Seal
4	Thread adapter nut	8	Optional heatable salt trap

Steps 1 to 3 are explained in detail in this section. The CLEANING - COMBUSTION PIPE service menu is used to remove and install the furnace.

Proceed as follows to remove the used furnace from the analyzer (Step 1):

1. Select CLEANING - COMBUSTION PIPE in the service menu.
2. Release the hoses on the injection unit (item 1).
3. Release the hose on the mounting plate or on the optional heatable salt trap.
4. Press the [E] key.
5. Release the locking button on the furnace and swivel the furnace outwards.
6. Disconnect the three connectors between the furnace and the analyzer. If the optional salt trap is fitted, also disconnect the electrical connection of the salt trap.
7. Remove the furnace from the analyzer, fit it in the exchange position on the furnace conditioning station and lock the position.
8. Press the [E] key.

Proceed as follows to install the new furnace in the analyzer (Step 2):

1. Switch off the heating switch and the main switch on the furnace conditioning station.
2. Release the hoses on the injection unit on the furnace conditioning station.
3. On the furnace conditioning station, disconnect the connections to the temperature sensors and the heater.
4. Remove the new furnace and insert it into the analyzer.
Mount the heatable salt trap (optional). Make sure that the seal seals the glass nozzle with a slight suction effect. You can adjust the seal with the clamp screw. The seal should not be too tight however.
5. Connect the plugs for the furnace and the temperature sensors.
6. Connect the hose to the mounting plate. If the optional salt trap is fitted, connect the hose directly to the salt trap.
7. Swivel the furnace to the end position and ensure that no hoses or pipes are buckled.
8. Press the locking button to secure the furnace position.
9. Press the [E] key twice.
10. Connect the hoses to the injection unit.
11. Press the [E] key.

Proceed as follows to place the used furnace in the maintenance position (Step 3):

1. Remove the used furnace from the exchange position and place it in the maintenance position.
2. Connect the temperature sensors. Switch on the main switch (**not** the heating switch). You can now see how the furnace cools down.

5.3 Cleaning the furnace

Prerequisite:

The furnace to be cleaned is in the maintenance position and has cooled down.

Proceed as follows to condition the furnace:

1. If the optional salt trap (item 8) is mounted, release the hose connection on the salt trap and remove the salt trap from the glass insert by gently moving it to and fro.
2. Release the knurled head screw (item 6)
3. Release the red cap (item 2) and remove the injection unit (item 1). The cap along with the O-ring and support ring remain on the furnace cover (item 3).
4. Release the thread adapter nut on the furnace entry (item 4) and remove the furnace cover.
5. Using the auxiliary tool (included in delivery of CA72TOC), pull the combustion pipe insert approx. 10 mm (0.4") out of the combustion pipe (item 5). Now remove the combustion pipe insert using the auxiliary tool and suspend the combustion pipe insert from the auxiliary tool.
6. Use heat-resistant gloves. The heat-resistant gloves must be suitable for a contact temperature of at least 150 °C (300 °F).
Lift the combustion pipe under the furnace and using the crucible tongs remove it from the furnace from the top.
7. To clean the combustion pipe, place it in 10% hydrochloric acid and then leave it dry.
Otherwise replace the pipe.

Proceed as follows to reassemble the combustion unit:

1. Insert the combustion pipe into the tube furnace.
2. Place the combustion pipe insert with filler (approx. 25 g high-temperature catalyst) into the combustion pipe.
3. Check and clean the sealing ring on the combustion pipe to the furnace cover and insert the sealing ring and the support ring.
4. Fit the furnace cover and the thread adapter nut (item 4) on the furnace entry and tighten the thread adapter nut securely.
5. Mount the cleaned injection unit and tighten the red cap.
6. If you are not using the optional salt trap, fit the glass insert with a glass fiber fabric as the salt trap. Roll two fabrics together loosely and put the fabrics loosely into the glass insert. Approx. 10 mm (0.4") must remain free at the top end to catch the salt.
7. If you are using the optional salt trap, leave the glass insert empty .
8. Insert the glass insert and a clean O-ring into the combustion pipe and tighten the knurled head screw hand-tight.
9. Insert the hose from the glass insert into the container for medium/condensate.

If you are using the optional heatable salt trap:

1. Fit the adapter (s. Abb. 5, item 2) on the glass insert nozzle.
2. Mount the bracket (s. Abb. 5, item 1).
3. Insert the hose into the container for medium/condensate.
4. Clean the heatable salt trap and keep it at the ready for subsequent installation in the analyzer.

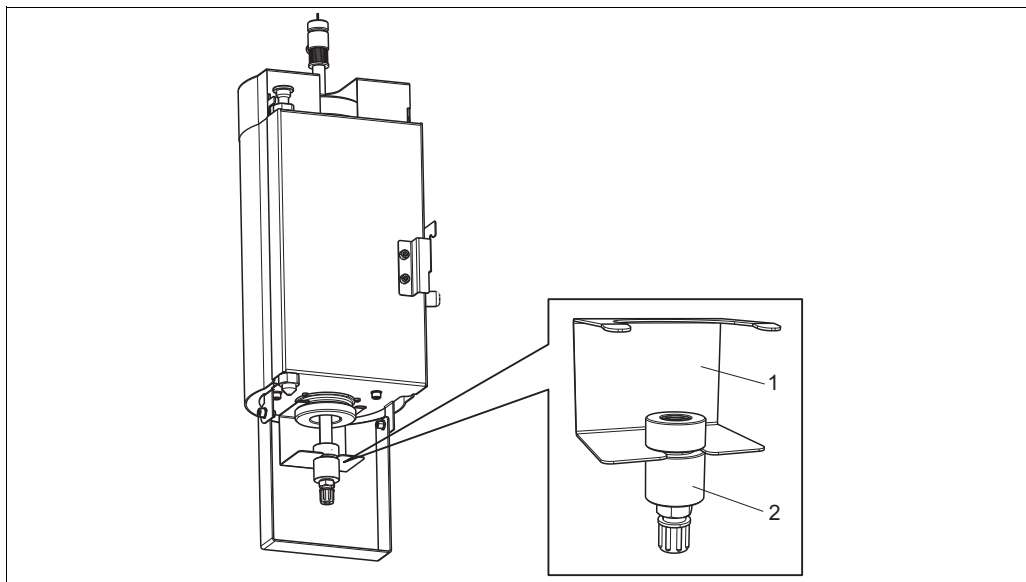

Fig. 5: Adapter

- 1 Bracket
- 2 Adapter

It is recommended to heat up the cleaned furnace at least 4 hours before scheduled furnace replacement.

Proceed as follows to heat up the furnace:

1. Top up the deionized water in the container.
2. Connect the temperature sensors and the heating.
3. Connect the hoses to the injection unit.
4. Switch on the main switch and the heating switch.

The diaphragm compressor conveys filtered ambient air through the reactor.

The heating regulator heats up the furnace to the set temperature. As soon as the set temperature is reached, the heating regulator activates the dosing pump. Power, air and deionized water is now supplied to the furnace until it is switched off.

6 Maintenance

6.1 Cleaning the furnace conditioning station



Caution!

When cleaning, make sure you do not damage the nameplate on the conditioning station! Do not use cleaning agents containing solvents!

Clean the housing as follows:

- Use fluoride-free cleaner (e.g. water or isopropanol) and a lint-free cloth.

6.2 Replacing the air filter and pump hose

The following parts might have to be replaced in the furnace conditioning station:

- Air filter
- Pump hose

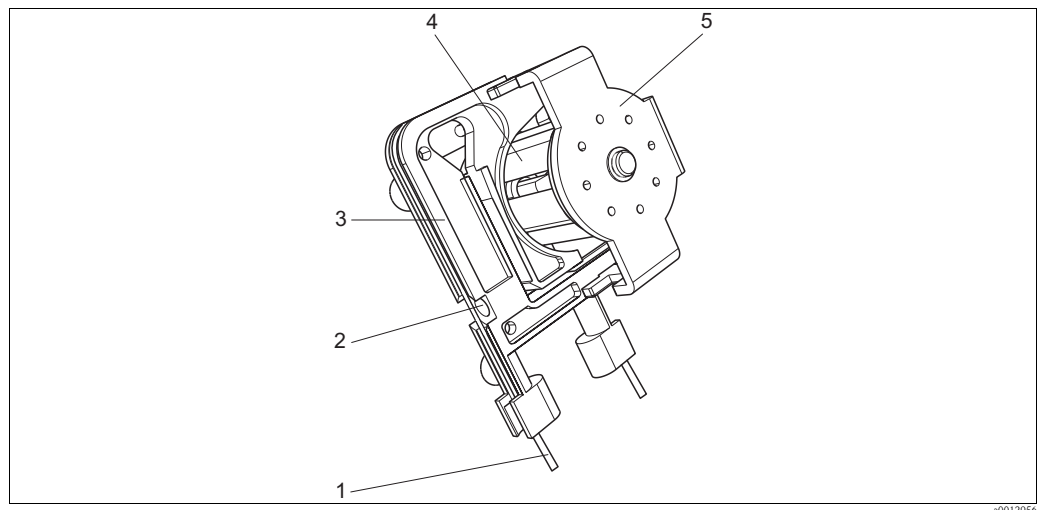

Fig. 6: Pump

- | | |
|---|--------------------------------|
| 1 | Sample hose 0.76 mm (0.03") ID |
| 2 | Adjusting screw |
| 3 | Hose cassette |

- | | |
|---|---------------|
| 4 | Pump head |
| 5 | Pump retainer |



Warning!

Danger of crushing! Never reach into the pump head while the pump is in operation!

You require the following parts:

- Silicone grease
- Dosing nozzle (injector)
- Paper towels to absorb liquids

Proceed as follows to replace the pump hose:

1. Switch off the main switch.
2. Loosen the screws of the pump cover and take off the cover.
3. Release the hose at the hose extension to the container for medium/condensate and to the injection unit.
4. Disengage the hose cassette (item 3).
5. Grease the new hose with a light coating of silicone grease.
6. Replace the hose (item 1).
7. Reengage the hose cassette.
8. Connect the hose to the hose extension to the container for medium/condensate and to the injection unit.
9. Remount the pump cover and tighten the screws.

Proceed as follows to replace the air filter:

1. Release the threaded connection of the air filter.
2. Change the air filter.

7 Spare parts

Maintenance kit for hoses

- Hoses, air filter and container for medium/condensate
- Order number: 71105994

Pump motor

- Order number: 71105996

Heating regulator

- Order number: 71105997

Thermostat

- Order number: 71105998

Diaphragm pump

- Order number: 71105999

Transformer 115/230 VAC; 600 VA

- Order number: 71106000

Furnace power supply

- Order number: 71106001

Temperature sensor connections

- Order number: 71106002

Kit combustion pipe

- Combustion pipe D 48 mm, ceramic
- With flange gasket D 53,9 x 63 x 3,1 mm, O-ring D 36,09 x 3,53 mm FKM
- Order number: 71101578

Kit combustion pipe insert for furnace in batch operation

- Insert for combustion pipe
- 75 g catalyst 800 ... 900 °C (1470 ... 1650 °F)
- Pre cut fiber glass for acid filter 24 x 230 mm
- Order number: 71101579

Kit combustion pipe insert for furnace in continuous operation

- Insert for combustion pipe
- 75 g catalyst
- Order number: 71101580

Kit furnace outlet for heated salt trap

- O-ring D 36,09 x 3,53 mm FKM, spherical washer, hollow bolt type II
- Order number: 71101581

Kit furnace outlet, standard

- Catalyst housing, O-ring D 36,09 x 3,53 mm FKM, spherical washer, hollow bolt type II
- Spacer mica washer, mica plate with holes
- Order number: 71101582

Kit injection

- Order number: 71101584

Kit catalyst material for furnace in continuous operation

- 2 x 75 g catalyst, 100 g filling material
- Order number: 71102294

Kit catalyst material for furnace in batch operation with and without heated salt trap

- 75 g catalyst 800 ... 900 °C (1470 ... 1650 °F)
- Pre cut fiber glass for acid filter 24 x 230 mm
- Order number: 71102295

8 Technical Data

8.1 Power supply

Supply voltage	115 V AC, 50/60 Hz, 600 VA, order number: 71103493 230 V AC, 50/60 Hz, 600 VA, order number: 71103492
Fuse	2.5 A slow blow 6.3 x 32 mm The replacement of the fuse has to be performed by trained customer or by Endress+Hauser service.

8.2 Environment

Ambient temperature range	5 to 35 °C (41 to 95 °F)
Humidity	10 to 90 %, non-condensing
Degree of protection	IP 54
Storage and transportation conditions	Store the device in a dry place only. Choose suitable packaging material to store the device.

8.3 Mechanical construction

Weight	230 V version: approx. 12 kg (26.5 lbs) 115 V version: approx. 15 kg (33.1 lbs)
Dimensions	Without furnace (B/H/D): 400/690/260 mm (15.8"/27.2"/10.2") With furnace (B/H/D): 600/690/260 mm (23.6"/27.2"/10.2")

Index

C

Cleaning	15
Commissioning	4

D

Declaration of conformity	6
Designated use	4

E

Electrical connection	8
Electromagnetic compatibility	4

F

Furnace	
Cleaning	13
Exchanging	10

I

Icons	5
Incoming acceptance	7
Installation	4,7

M

Maintenance	15
-------------------	----

N

Nameplate	6
-----------------	---

O

Operation	4
Operational safety	4
Overview	9

P

Power supply	18
--------------------	----

R

Return	4
--------------	---

S

Safety icons	5
Scope of delivery	6
Spare parts	17
Storage	7
Symbols	5

T

Technical Data	18
Transport	7

U

Use	4
-----------	---

W

Wiring	8
--------------	---

www.endress.com/worldwide

Endress+Hauser 
People for Process Automation

