

Mark/Space communication protocol

Tank Side Monitor NRF590

Inventory Control

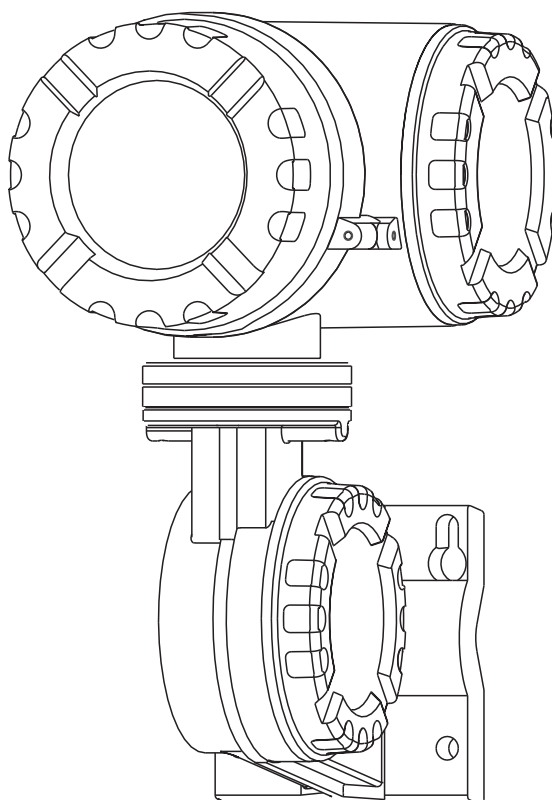

Table of contents

1	Introduction	4
2	Implementation	4
3	Configuration	5
3.1	Address	5
3.2	Configuration settings	5
4	Measured values	7
4.1	Measured Value Ranges	7
4.2	Measured Value Error Handling	7
5	Mark/Space Message Formats	8
5.1	Physical Layer	8
5.2	Request Message	8
5.3	Reply Message	8

1 Introduction

This protocol guide explains the operation of the Mark/Space protocol implemented in the Endress+Hauser Tank Side Monitor NRF 590.

2 Implementation

The implementation of the Mark/Space protocol for the Tank Side Monitor provides a standard form of digital communication via a voltage mode bus. An effort has been made to parallel current implementations to the greatest extent possible, so that the Tank Side Monitor communicates with existing Mark/Space masters.

Check compatibility carefully to ensure that the Tank Side Monitor is properly configured for the data format expected by the host system or computer. Exceptions made because of the unique requirements of the Tank Side Monitor application have been noted.



Note!

This is no guarantee, however, that the interpretation made here will be the same as that followed by the Mark/Space master.

The Mark/Space interface supports two types of communication which are based on the emulation of older devices.

Mark/Space Types

Device Type	Description
1900	Emulates the Model 1900 transmitter
1800	Emulates the Model 1800 transmitter

3 Configuration

The Mark/Space interface on the Tank Side Monitor must be configured to establish communications. The local display or ToF tool allows the user to set the Tank Side Monitor Mark/Space interface to match the Mark/Space master settings.

3.1 Address

Tank Side Monitor addresses provide unique identification for the host. The Tank Side Monitor address is configurable through the local display or ToF tool. This address may range from 0 to 999 and must be unique for each Mark/Space device on a bus. Each Tank Side Monitor only responds when a query has been sent to its unique address by the host.

3.2 Configuration settings

In order for successful communication on a Mark/Space bus a number of configuration settings must be made to match the configuration of the bus.

3.2.1 Summary of Configuration Parameters

A summary of the configuration information required by the Tank Side Monitor is shown in the following table.

Mark/Space configuration parameters

Configuration parameter	Valid Entries	Default
ID	0 ... 999	1
Type	<ul style="list-style-type: none"> ■ 1900 ■ 1800 	1900
Baudrate	<ul style="list-style-type: none"> ■ High ■ Low 	High
Data Mode	<ul style="list-style-type: none"> ■ 20 m ■ 30 m ■ Decimal ■ Fracional 	20 m
Temperture	<ul style="list-style-type: none"> ■ With Temp ■ No Temp 	With Temp
TempOffset	<ul style="list-style-type: none"> ■ Enable ■ Disable 	Disable
Alarm Ref 1	Any Discrete Value	IS Digital In 1
Alarm Ref 2	Any Discrete Value	IS Digital In 2

3.2.2 Description of Configuration Parameters

ID (9211)

This is a unique number for this device on the Mark/Space bus, only when the Tank Side Monitor receives a request message with this number is a response generated.

Type (9213)

Specifies the format of the response generated by the Tank Side Monitor. The selection influences the representation of the temperature within the response.

Baud Rate (9212)

Specifies the communication speed used on the Mark/Space bus.

Data Mode (9214)

Specifies additional formatting types for the response generated by the Tank Side Monitor. the selection influences the representation of the level within the response and whether the temperature is returned or not.

Temperature (9215)

Specifies if the temperature value is included in the reply message of the Tank Side Monitor or not. A full description of these response formats is given in section 2.

TempOffset (9216)

When enabled causes a -100.0 degrees offset to be applied to the applied to the temperature in the response by the Tank Side Monitor.

Alarm Ref 1 (9214)

Indicates which discrete value will be transmitted as MS Discrete Value 1. The default value is connected to the IS DI 1.

Alarm Ref 2 (9215)

Indicates which discrete value will be transmitted as MS Discrete Value 2. The default value is connected to the IS DI 2.

4 Measured values

4.1 Measured Value Ranges

The Mark/Space response will contain 2 measurement values; level and temperature as well as 2 alarm bits indicating the status of the two Tank Side Monitor discrete IOs. Depending on the setting of the Mark/Space parameters these values are subject to the following limits.

4.1.1 Level

Measurement Value	Mode/Type	Value Range	Units
Level ¹⁾	Fractional	0-0-0 ... 79-11-15	ft-in-16 ^{ths}
	Decimal	0.0 ... 79.99	ft
	20 meters	0.0 ... 19.999	m
	30 meters	0.0 ... 32.699	m
Temperature ²⁾	1800	-199.9 ... +199.9	Tank Temp Units
	1900	-799.9 ... +799.9	Tank Temp Units
Alarm 0	State Alarm Ref 1		
Alarm 1	State Alarm Ref 2		

1) The level is obtained from the Level value.

2) The temperature is obtained from the TANK Temperature value.

For a detailed description of the message formats see → Chap. 1.

4.2 Measured Value Error Handling

The following error handling rules are applied to all values returned in the Mark/Space message. Refer to the Table → Chap. 1.1.1 for related minimum and maximum values.

1. If the Tank Corrected Level is not valid or outside of the value range shown an illegal gray code is transmitted in the level position of the reply, see → Chap. 1 for details.
2. If the Tank Temperature is greater than the maximum shown then
 - a. for Device Type = 1800: Bit 43 of the reply is set and the temperature value should be ignored.
 - b. for Device Type = 1900: The maximum value is returned.
3. If the Tank Temperature is less than the minimum shown then
 - a. for Device Type = 1800: Bit 43 & bit 40 of the reply are set and the temperature value should be ignored.
 - b. for Device Type = 1900: The minimum value is returned.

5 Mark/Space Message Formats

5.1 Physical Layer

The Mark/Space communication takes place on a pair of voltage mode cables normally at 48VDC (one called Mark the other called Space). Bits are represented by either one or the other of these cables going low to (0VDC), logic 1 if it is the Mark line or logic 0 if it is the Space line. The width of the pulses and the gaps between them are determined by the Mark/Space "Speed Mode" parameter.

These bits are then assembled in to message blocks.

5.2 Request Message

The request is a sequence of 16 data bits sent from the control room, these bits encode the device whose data is requested as well as special function bits for the 6500 servo gauge.

Mark/Space Request Message

Bit	Description
1 st	Start bit
2 nd	Unused bit
3 rd	Raise command (for 6500 servo gauge)
4 th	Reset command (for 6500 servo gauge)
5 th ... 8 th	Device ID 100 (bit 8 is the least significant of the BCD digit)
9 th ... 12 th	Device ID 10 (bit 12 is the least significant of the BCD digit)
13 th ... 16 th	Device ID 1 (bit 16 is the least significant of the BCD digit)

5.3 Reply Message

The reply from the Tank Side Monitor depends on the Mark/Space interface settings of the Tank Side Monitor.

5.3.1 40-bit Response (for all Data Modes with "No Temp")

For all Data Modes with "No Temp" the reply from the Tank Side Monitor consists of 40 bits of information arranged as follows.

Bit	Description
1 st	Start bit
2 nd and 3 rd	Unused bit
4 th ... 7 th	Device ID 100 (bit 8 is the least significant of the BCD digit)
8 th ... 11 th	Device ID 10 (bit 12 is the least significant of the BCD digit)
12 th ... 15 th	Device ID 1 (bit 16 is the least significant of the BCD digit)
16 th	First data bit always 0
17 th ... 37 th	Level Data
38 th	Alarm 1 (state of Alarm Bit 2)
39 th	Alarm 0 (state of Alarm Bit 1)
40 th	Parity bit

5.3.2 56-bit Response (for all Data Modes with "No Temp")

For all Data Modes with "Temp" the reply from the Tank Side Monitor consists of 56 bits of information arranged as follows.

Bit	Description
1 st	Start bit
2 nd and 3 rd	Unused bit
4 th ... 7 th	Device ID 100 (bit 8 is the least significant of the BCD digit)
8 th ... 11 th	Device ID 10 (bit 12 is the least significant of the BCD digit)
12 th ... 15 th	Device ID 1 (bit 16 is the least significant of the BCD digit)
16 th	First data bit always 0
17 th ... 37 th	Level Data
38 th	Alarm 1 (State of Alarm Ref 2)
39 th	Alarm 0 (State of Alarm Ref 1)
40 th ... 55 th	Temperature Data
56 th	Parity bit

5.3.3 Level Data

The level data part of the reply from the Tank Side Monitor consists of 21 bits of information arranged as follows depending on the Data Mode setting.

Data Mode = Fractional

Bit	Description
16 th	First data bit always 0
17 th ... 19 th	Feet 10
20 th ... 23 rd	Feet 1
24 th ... 27 th	Inches
28 th ... 31 st	16 ^{ths} inch
32 nd ... 37 th	filled with 0

Data Mode = Decimal

Bit	Description
16 th	First data bit always 0
17 th ... 19 th	Feet 10
20 th ... 23 rd	Feet 1
24 th ... 27 th	Feet 0.1
28 th ... 31 st	Feet 0.01
32 nd ... 37 th	filled with 0

Data Mode = 20m

Bit	Description
16 th	Meters 10
17 th ... 20 th	Meters 1
21 st ... 24 th	Meters 0.1
25 th ... 28 th	Meters 0.01
29 th ... 32 nd	Meters 0.001
33 rd ... 37 th	filled with 0

Data Mode = 30m

Bit	Description
16 th ... 17 th	Meters 10
18 th ... 21 st	Meters 1
22 nd ... 25 th	Meters 0.1
26 th ... 29 th	Meters 0.01
30 th ... 33 rd	Meters 0.001
34 th ... 37 th	filled with 0

Each level digit is encoded using reflected binary gray pulse coding.

5.3.4 Temperature Data

The temperature data part of the reply from the Tank Side Monitor consists of 16 bits of information arranged as follows depending on the Device Type setting:

Bit	Device Type = 1800	Device Type = 1900
40 th	Error bit	Temperature 100 (bit 0) ¹
41 st	Sign (1 = +ve Temperature)	Sign (1 = +ve Temperature)
42 nd	Unused	Temperature 100 (bit 1) ¹
43 rd	Error bit	Temperature 100 (bit 2) ¹
44 th ... 47 th	Temperature 10	Temperature 10
48 th ... 51 st	Temperature 1	Temperature 1
52 nd ... 55 th	Temperature 0.1	Temperature 0.1

¹These bits are inverted.

www.endress.com/worldwide

Endress+Hauser 
People for Process Automation

