

Level Probe *multicap DC 21*

Fully insulated rope probes



Applications

The Multicap DC 21 probe is designed for continuous level measurement in electrically conducting liquids and limit detection in all types of liquid. The wide selection of corrosion-resistant materials used for the probe rope, insulation and process connection ensures that the probe can withstand extremely corrosive products. The tried-and-tested, rugged construction is gas-tight for pressures from vacuum to 50 bar (725 psi) gauge. Seal and insulation materials enable it to be used with operating temperatures in the vessel of -80°C to $+200^{\circ}\text{C}$ (-110°F to $+390^{\circ}\text{F}$).

Your benefits

- Optimum adaptation to your application thanks to a wide range of process connections and practical variations
= reliable function at a cost-effective price
- Protection against condensation in the nozzle
= reliable function even with condensation
- Active build-up compensation for limit detection
= constant and accurate switchpoint even with heavy build-up on the probe, no cleaning or recalibration required

Endress + Hauser

The Power of Know How



Measuring System

The measuring system comprises:

- Multicap DC 21 probe
- EC electronic insert in the probe housing
- Silometer FMC (Z) transmitter or Nivotester FTC (Z) level limit switch

For limit detection in liquids with heavy build-up or for detecting interface layers, the measuring system comprises:

- Multicap DC 21 probe with active build-up compensation
- EC 16 Z electronic insert
- FTC 520/521 Z or FTC 470/471 Z level limit switch.
The limit input of the Silometer FMC 671 Z can also be connected.

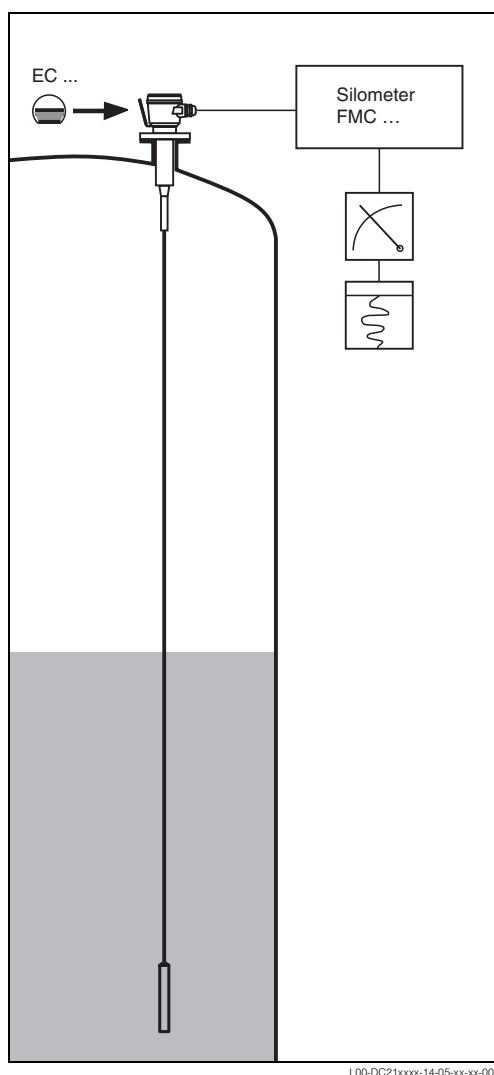

*Continuous measurement,
e.g. using probe with screening against
condensation in the nozzle*

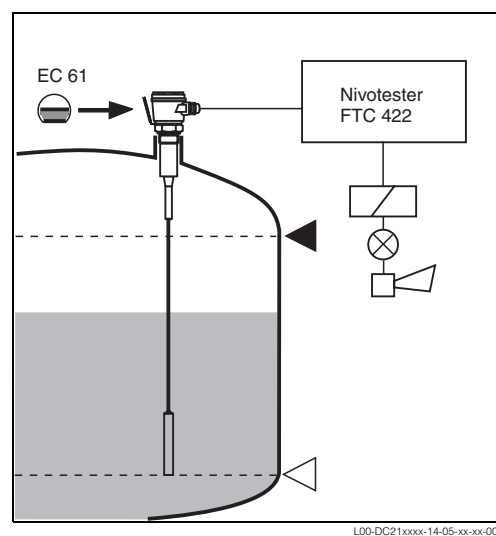

Two-point control

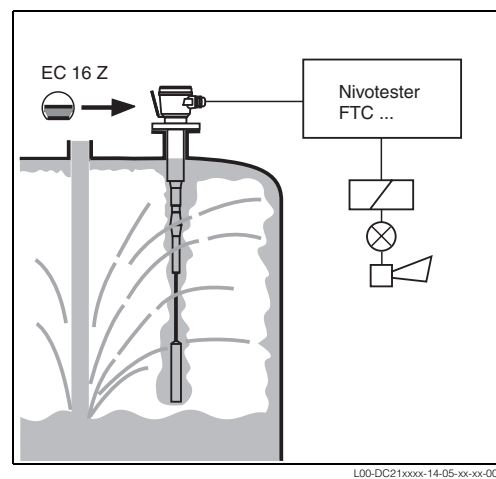

*Limit detection,
e.g. using probe with screening and active build-up
compensation for reliable limit switching even in the
presence of heavy build-up*

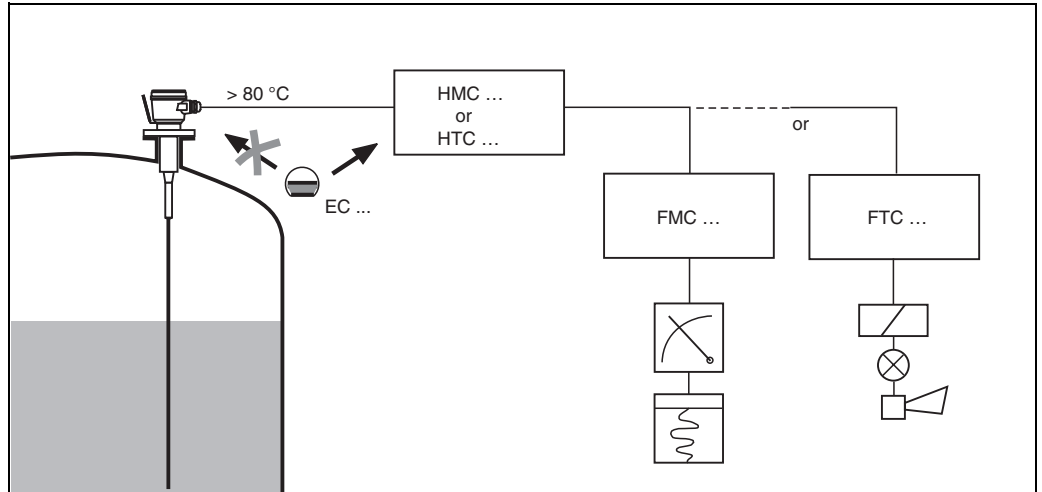

L00-DC21xxxx-14-05-xx-en-001

Separate mounting of the electronic insert in the case of an excessively high ambient temperature at the probe head housing

Certified Applications

Please note that in addition to the instructions given in this Technical Information, the specifications in the certificates and relevant local regulations apply.

Operating Principle

The probe and vessel wall or counter-electrode form a capacitor with a defined, low capacitance when the probe is uncovered.

As soon as material covers the probe a parallel circuit is formed consisting of a much larger capacitance and the resistance of the material – the impedance.

This means that for materials with a conductivity which exceeds a specific, low threshold, any changes in dielectric constant and, therefore, in the capacitance no longer affect the measurement.

Screening on the probe prevents effects caused by build-up of material or condensation in the vicinity of the process connection. Probes with active build-up compensation for limit switching cancel out effects of build-up on the probe.

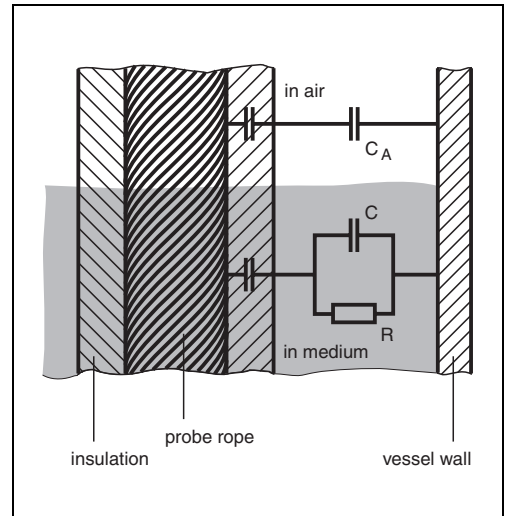

L00-DC21xxxx-05-05-xx-en-001

Equivalent circuit for capacitance measurement with fully insulated probes

Probe Selection

Here are a few notes on the various designs for the fully insulated Multicap DC 21 probe:

1. Basic probe

- for standard applications

2. Probe with screening

- for long nozzles
- when condensation forms on the roof of the vessel
- for build-up on the vessel wall, e.g. through splashing

3. Probe with fully insulated screening

- as above but for especially corrosive materials

4. Probe with active build-up compensation for limit detection

- for heavy (conductive) build-up on the probe.
- The active build-up compensation of the Multicap DC 21 probe is always gas-tight due to the self-adjusting tapered gasket. A wide range of corrosion-resistant materials ensures that the probe can be used in metallic tanks containing aggressive liquids.

5. Probe with gas-tight gland

- for liquefied gas tanks (required in Germany)
- to prevent condensation forming within the probe on extreme temperature variations. See temperature graphs overleaf.

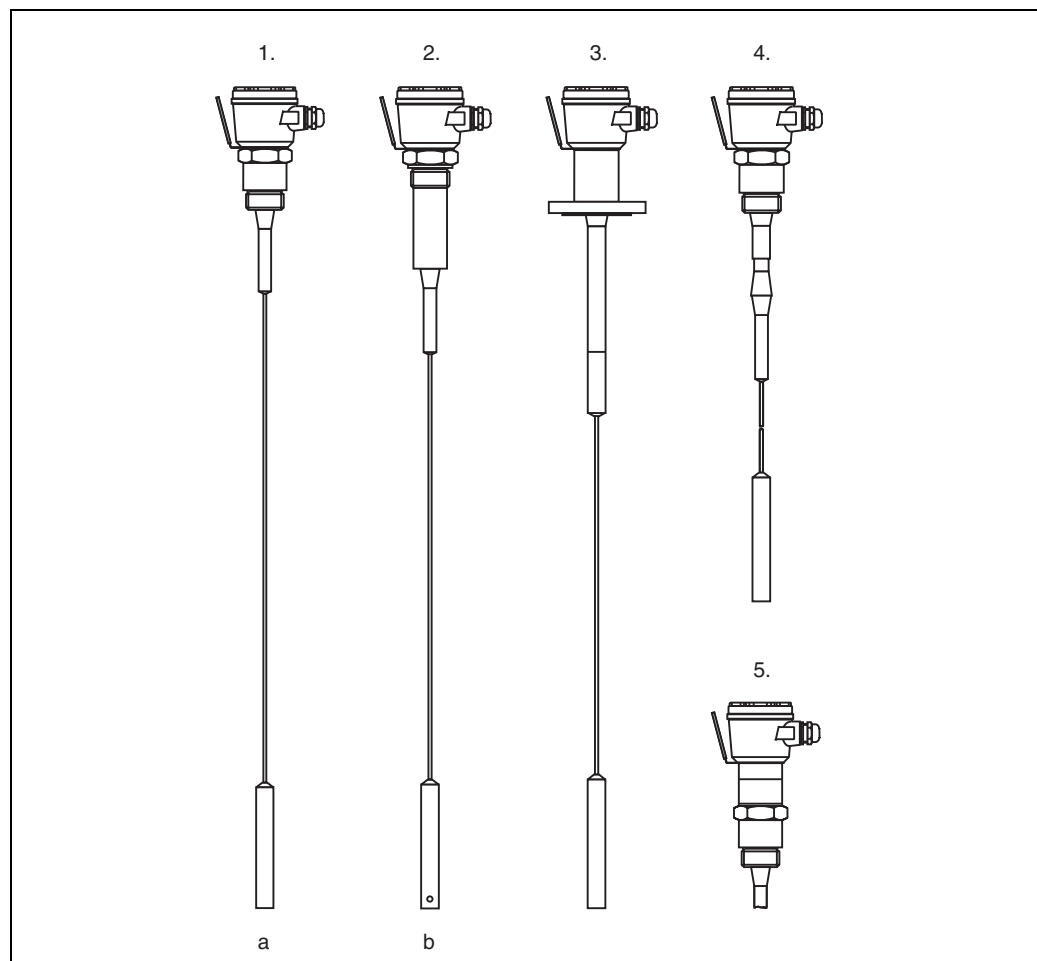

Fully insulated rope probe versions
 a) Tensioning weight
 b) Anchor weight with insulated bore

L00-DC21xxxx-03-05-xx-xx-000

6. Probe with temperature spacer

- for an extended range of operating temperatures in the vessel.
See also temperature graphs.

7. Probe without electronic insert

- for high temperatures in the probe housing:
use electronic insert in separate housing.
See also temperature graphs.

8. Probe with protective cover

- (accessory)
- to prevent condensation forming in the aluminium housing.

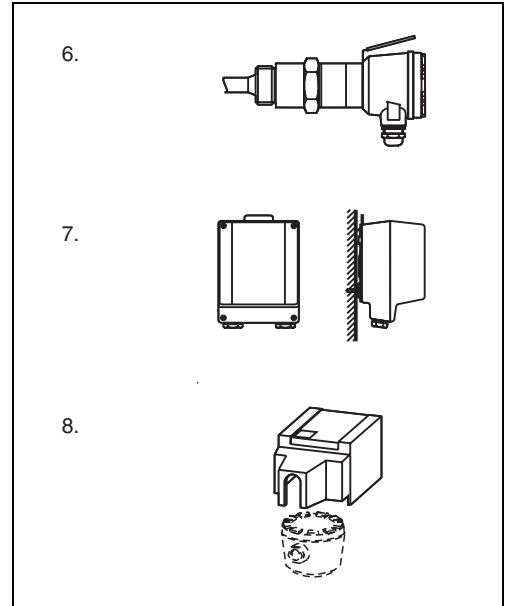

L00-DC21xxxx-03-05-xxxx-001

Further variations outside the product tank

Electronic Insert

Separate or Built-In?

Information is provided by the graphs on the right.

The horizontal axis is the operating temperature T_B in the vessel.

The vertical axis is the ambient temperature T_U of the probe housing (in °C).

- Do the temperatures lie in the grey area of graph **A**?
The electronic insert may be mounted in the housing of any probe.
- Do the temperatures lie in the grey areas of graph **B**?
The electronic insert may be mounted in the housing of a probe with a temperature spacer or gas-tight gland; or it may be mounted in a separate housing.
- Do the temperatures lie in the grey areas of graph **C**?
The electronic insert should be mounted in a separate housing.
- Do the temperatures lie in the grey area of graph **D**?
Use a probe with a temperature spacer or a gas-tight gland and mount the electronic insert in a separate housing.

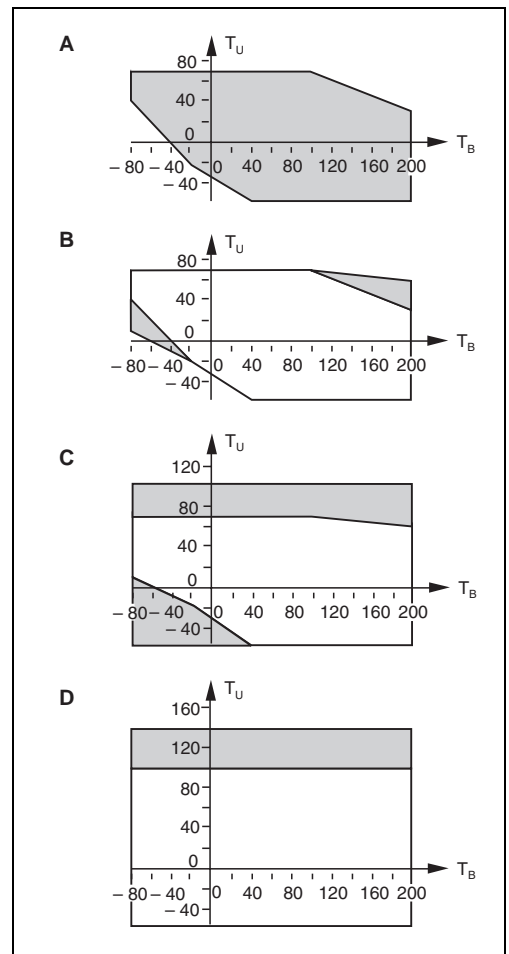

L00-DC21xxxx-05-05-xxxx-001

Application range of the various types as a function of operating and ambient temperature

$$x \text{ } ^\circ\text{C} = (x \cdot 1.8 + 32) \text{ } ^\circ\text{F}$$

Dimensions in mm (100 mm = 3.94 in / 1 in = 25.4 mm)

**Probes for Both
Continuous Level
Measurement and
Limit Detection**

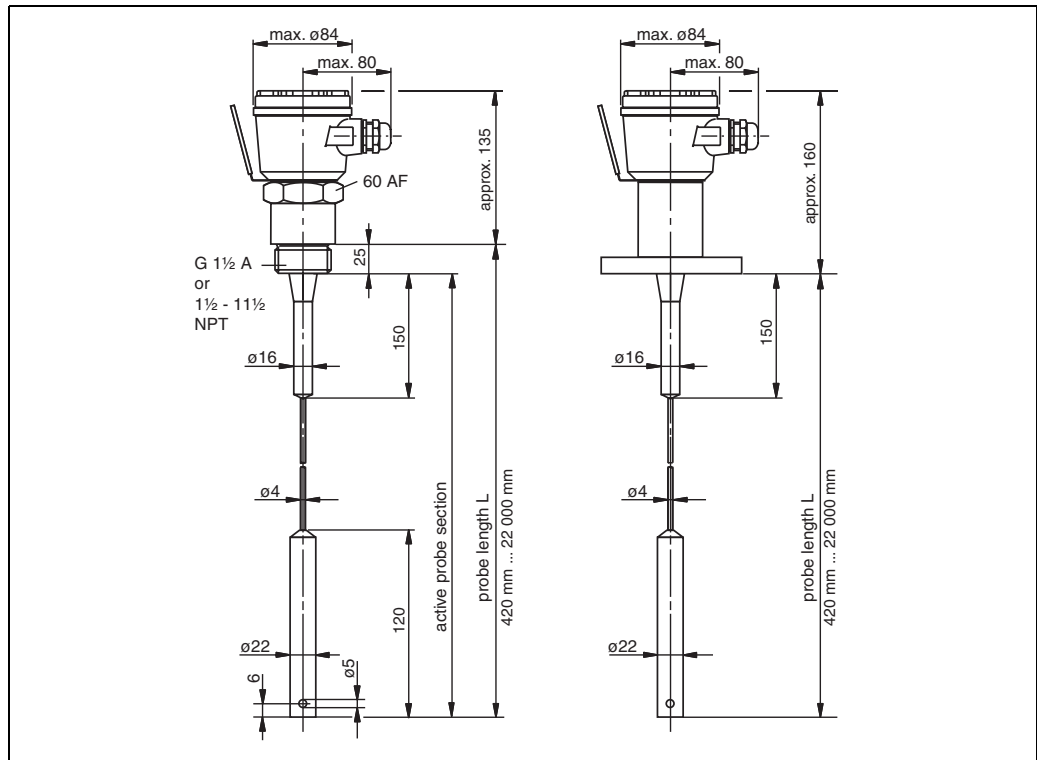

L00-DC21xxxx-06-05-xx-en-001

From left to right:
Multicap DC 21 with threaded boss
Multicap DC 21 with flange

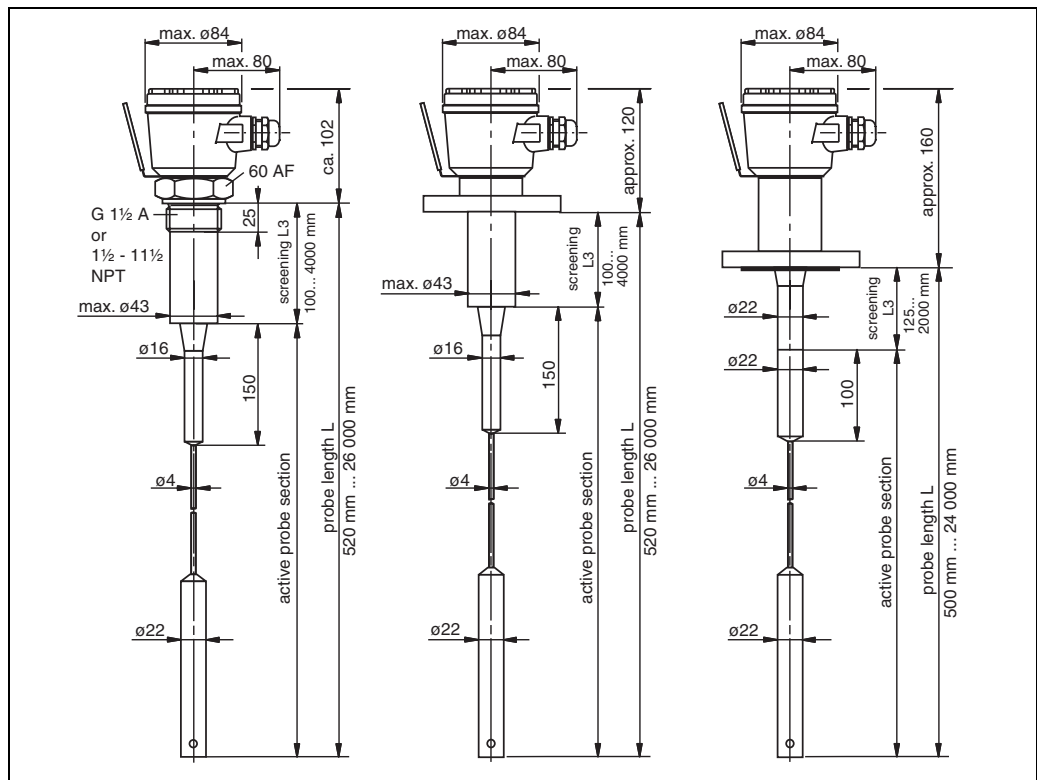

L00-DC21xxxx-06-05-xx-en-002

From left to right:
Multicap DC 21 with threaded boss and uninsulated metallic screening
Multicap DC 21 with flange and uninsulated metallic screening
Multicap DC 21 with PTFE-clad flange and fully insulated screening

**Probes for Limit Detection
with Build-Up
Compensation**

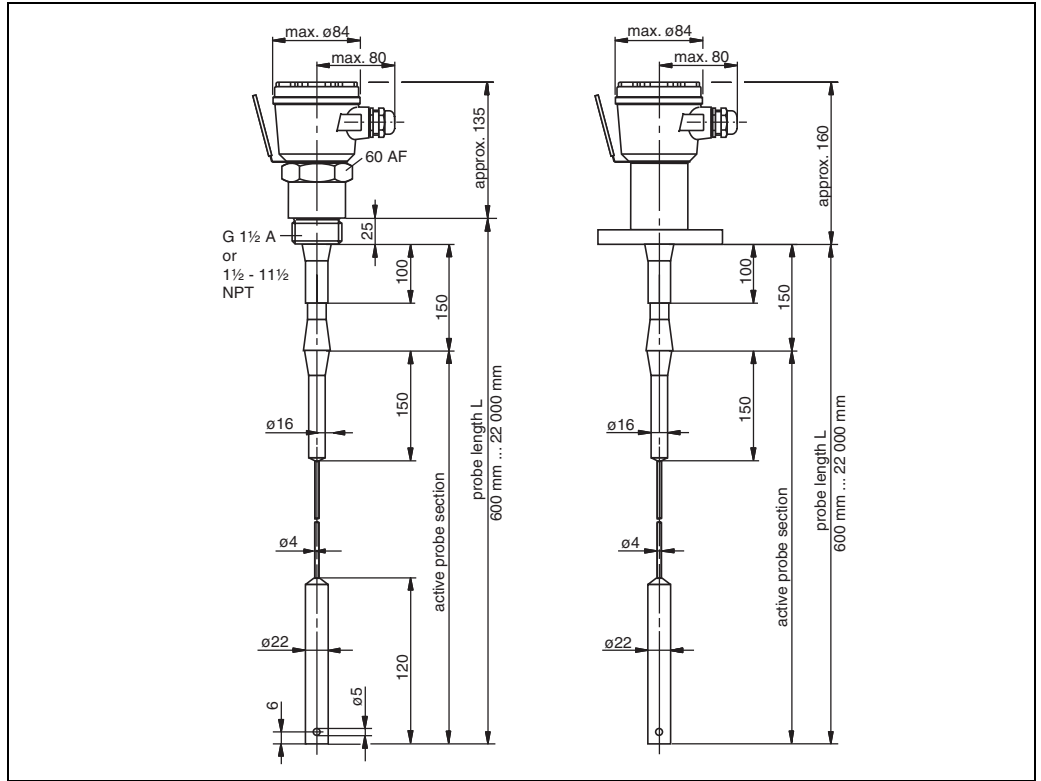

L00-DC21xxxx-06-05-xx-en-003

From left to right:
 Multicap DC 21 with threaded boss and active build-up compensation
 Multicap DC 21 with flange and active build-up compensation

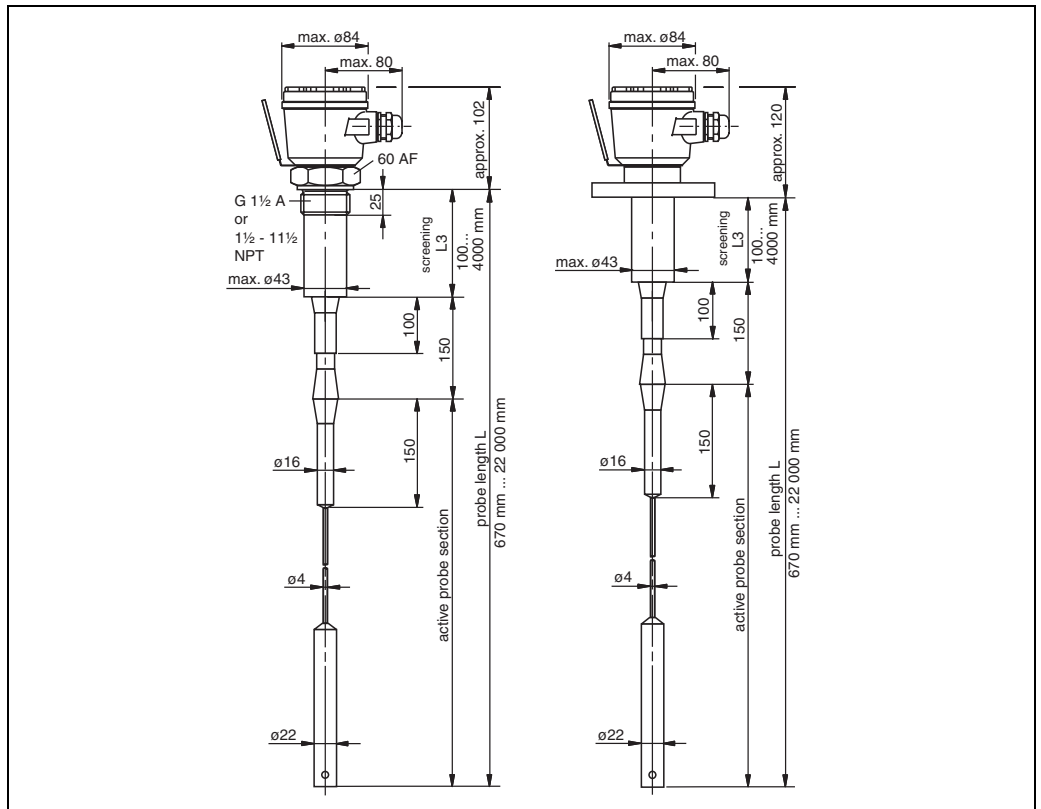

L00-DC21xxxx-06-05-xx-en-004

From left to right:
 Multicap DC 21 with threaded boss, screening and active build-up compensation
 Multicap DC 21 with flange, screening and active build-up compensation

**Other Process Connections
Gas-Tight Gland
Temperature Spacer**

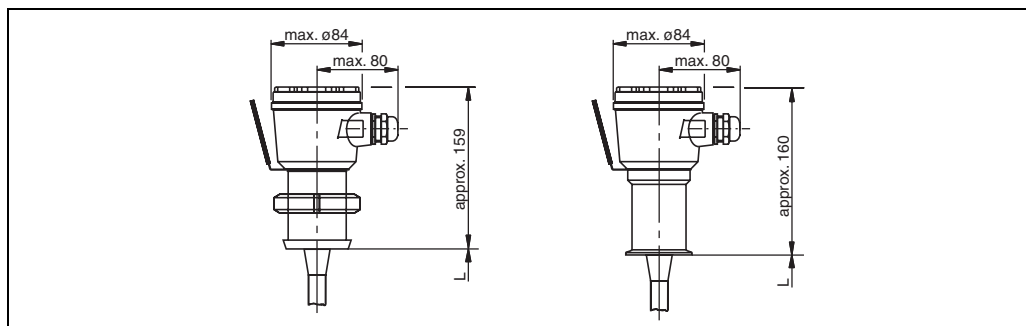

L00-DC21xxxx-06-05-xx-en-005

left: Multicap DC 21 with sanitary thread DIN 11851-DN 50
right: Multicap DC 21 with 2" Triclamp coupling

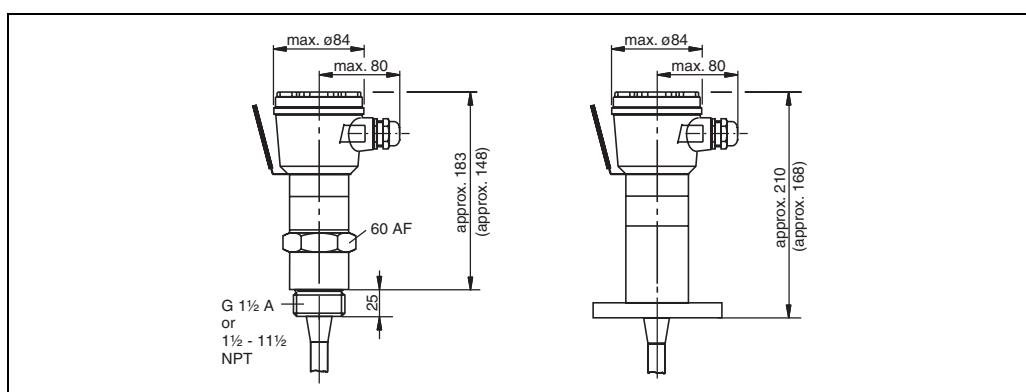

L00-DC21xxxx-06-05-xx-en-006

left: Multicap DC 21 with threaded boss and gas-tight gland
right: Multicap DC 21 with flange and gas-tight gland

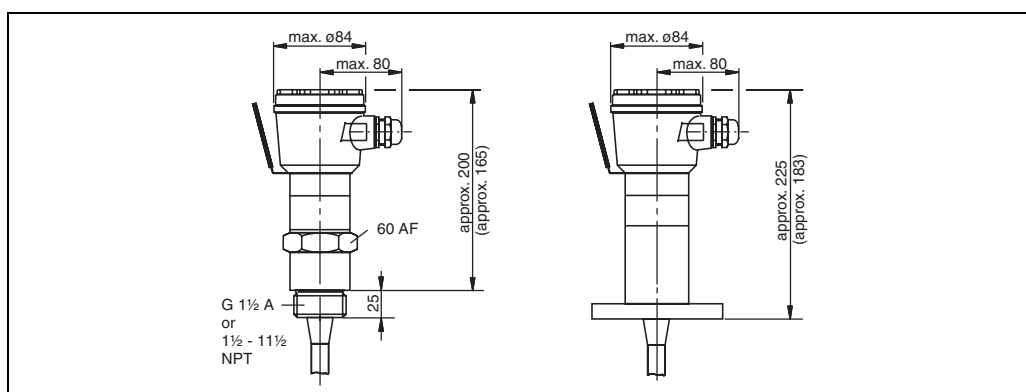

L00-DC21xxxx-06-05-xx-en-007

left: Multicap DC 21 with threaded boss and temperature spacer
right: Multicap DC 21 with flange and temperature spacer

(Dimensions for the DC 21 with screening are shown in brackets)

Transport, Unpacking

- To avoid damage to the probe, remove the packaging on-site just before mounting. The uninsulated section of probes with active build-up compensation is covered with plastic webbing. This protection should be removed prior to mounting.
- Compare the code on the nameplate of the probe with the product designation on Page 12 to ensure that the correct probe has been delivered.

- Check the probe length. The probe rope can be shortened with the aid of the rope shortening kit (accessory).

Installation

- Probe with parallel thread G 1 ½ A:
Use the elastomer/fibre seal provided or any other chemically resistant seal which can withstand temperatures up to 300°C (570°F).
- Probe with tapered thread 1 ½ - 11 ½ NPT:
If required, wrap suitable sealing material around the thread.
- Probe with flange connection:
Use a sealing material suitable for the application. If the flange is PTFE-clad, then this is generally a suitable seal up to the permitted operating pressure.
- Make sure that the probe insulation is not damaged when sliding the probe through the threaded sleeve or nozzle with counter-flange.
- When tightening, turn the probe with threaded boss at the hex nut only; not at the housing!
- For probes with the G 1 ½ A thread and seal:
a torque of only 300 Nm is sufficient to seal tight against a pressure in the vessel of up to 50 bar (725 psi). Maximum admissible torque: 600 Nm.
- A polypropylene threaded boss with rubber seal may only be tightened using a max. torque of 7 Nm (1 Nm = 0.74 ft lbs).
- If the probe is to be anchored, where possible use an insulated rope, tension to a maximum force of 200 N (20 kg/44 lbs).

Rotating the Housing

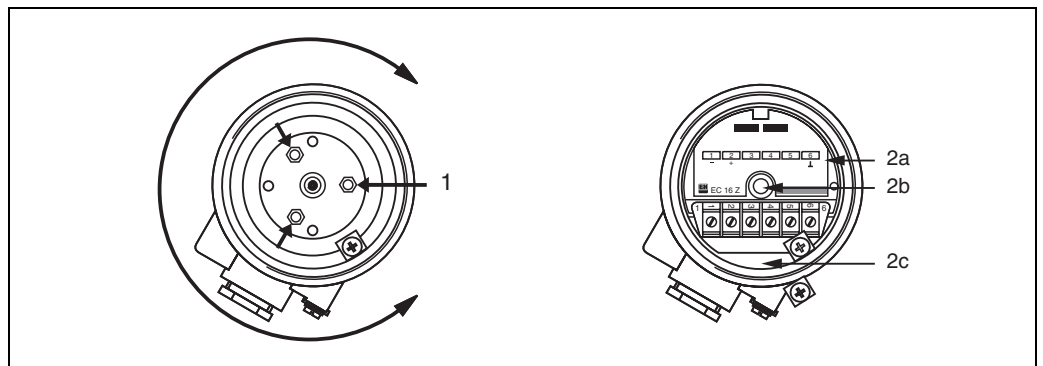

- 1) The housing can be rotated after the 3 nuts have been loosened
- 2) Tighten electronic insert (a) with the central slotted nut (b) leaving space (c) for the connecting cable

The housing can be rotated if the cable gland is pointing in the wrong direction after mounting.

- To loosen:
- Unscrew the housing cover
 - Unscrew the central nut (slotted nut) in the electronic housing
 - Remove the electronic insert from the housing
 - Slightly loosen the 3 nuts (7 AF), see Figure.

To rotate: The housing can now be rotated in any direction.

- To tighten:
- Securely tighten the 3 nuts in the housing so that the housing is tight against the hex nut.
 - Insert the electronic insert and securely tighten the central nut so that it does not become loose. Ensure that the cable gland remains free.

Connection

Refer to the appropriate Technical Information concerning the electronic insert EC used in the probe housing.

In the case of the heavy duty housing, the connection diagram corresponds to that of the built-in electronic insert. It is important that no moisture enters the probe housing during storage of the probe, connection of the electronic insert and during operation. Always tighten the housing cover and cable gland securely.

If the probe is installed in a plastic tank, connect the ground terminal of the probe to the counter-electrode using a short cable.

Replacing components

Mounting without electronic insert Exchange of electronic inserts

- After the defective electronic insert has been removed and the replacement properly installed, the instrument must be recalibrated and checked for correct function.
- If fully insulated multicap probes are mounted in explosion hazardous areas without the electronic insert, and there is a risk of dangerous electronic discharges, then the probe terminal in the housing must be short-circuited with the ground terminal.

Technical Data

Operating Data

- See graphs for the relationship between operating pressure and temperature.
- Capacitance values of the probe
Basic capacitance: approx. 30 pF
Other capacitance values:
Gas-tight gland: approx. 20 pF
Temperature spacer: approx. 20 pF
Active build-up compensation: approx. 10 pF
Screening: approx. 3 pF/100 mm
Fully insulated screening: approx. 6 pF/100 mm
Probe 250 mm from a conductive vessel wall:
Insulated probe rope:
approx. 1 pF/100 mm in air
approx. 20 pF/100 mm in water
Insulated tensioning weight:
approx. 2 pF in air
approx. 60 pF in water
Temperature dependence of the rope capacitance: < 0.1% per °C
Pressure dependence of the rope capacitance: < 0.1% per bar
(in conducting liquids;
in non-conducting liquids negligible)
- Tensile strength of rope probe (anchoring):
max. 200 N at 20°C.

$$x \text{ } ^\circ\text{C} = (x \cdot 1.8 + 32) \text{ } ^\circ\text{F}$$

$$1 \text{ bar} = 14.5 \text{ psi}$$

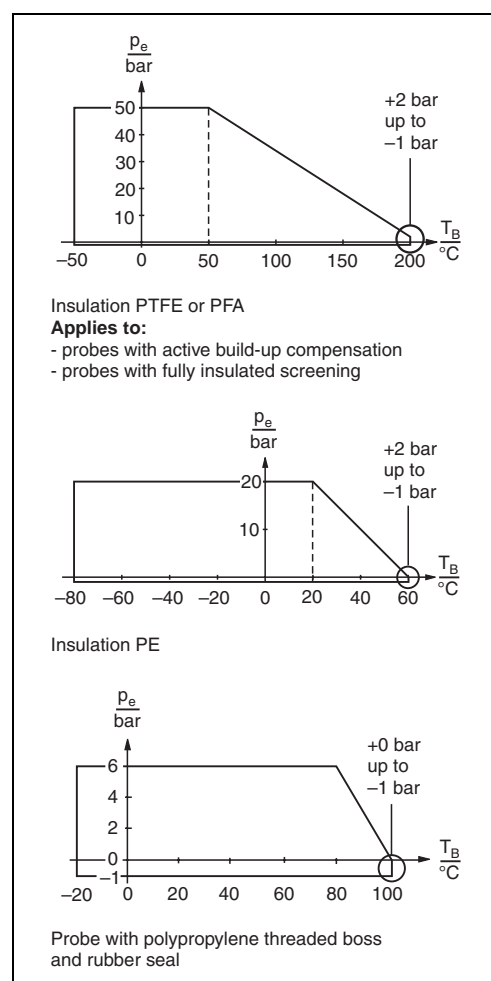

L00-DC21xxxx-05-05-xx-en-002

Permitted operating pressures p_e and temperatures T_B

**Probe Lengths
(100 mm = 3.94 in)**

- Total length of probe rope: max. 22.000 mm
- Length of uninsulated screening: L3 min. 100 mm, max. 4000 mm
- Length of fully insulated screening: L3 min. 125 mm, max. 2000 mm
- Length of active build-up compensation: always 150 mm from where the probe rod leaves the process connection or screening.
- Length tolerances
 - up to 1 m: +0 mm, -5 mm
 - up to 3 m: +0 mm, -10 mm
 - up to 6 m: +0 mm, -20 mm
 - up to 26 m: +0 mm, -30 mm

**Process Connection
Standards**

- Parallel thread G 1 ½ A: DIN ISO 228/1, with sealing ring 48 x 55 to DIN 7603
- Tapered thread 1 ½ - 1 ½ NPT: ANSI B 1.20.1
- DIN flanges: see flange table
- ANSI flanges: ANSI B 16.5
- Sanitary thread: DIN 11851
- Triclamp coupling: ISO 2852

Materials

Most material specifications are given in the Product Structure on page 12

- Housing: cast aluminium AlSi 12, resistant to sea-water, EP-lacquered
- Aluminium housing, coated: in fluoropolymer
- Sealing between housing and process connection: EPDM
- Sealing for housing cover: O-ring in EPDM
- Temperature spacer: SS 304 H (1.4301)
- Gas-tight gland: SS 304 H (1.4301)
- Sealing ring for process connection G 1 ½ A: elastomer/fibre, asbestos-free, resistant to oil, solvents, steam, weak acids and alkalis; up to 300°C and 100 bar (570°F and 1450 psi)
- Cable glands: standard PG in nickel-plated brass with NBR seal for cable diameter 7...10 mm; Protection IP55 ; ambient temperature up to 100°C (210°F)
- Watertight PG in polyamide with neoprene/CR seal for cable diameter 5...12 mm; Protection IP66; ambient temperature up to 80°C (180°F)

See product structure for housing variations

Certificates

- EC-Type-examination certificate
PTB 98 ATEX 2215 X
CE II 1/2 G, EEx ia IIC/B T6
XA 024F/00/a3
- EC-Type-examination certificate
PTB 98 ATEX 2215 X
CE II 1/2 G, EEx ia IIC/B T6
XA 080F/00/a3
- DIBt test report to § 19 WHG
overspill protection with continuous level measurement (for Germany)
ZE 210F/00/de
- DIBt test report to § 19 WHG
for overspill protection with level limit switch (for Germany)
ZE 211F/00/de

Product Structure

Product Structure Multicap DC 21

Design		Basic weight	
DC 21	Fully insulated rope probe		2,0 kg
10	Certificate		
A	ATEX II 1/2 G EEx ia IIC T6		
D	For non-hazardous areas	Overspill protection to WHG	
F	ATEX II 1/2 G EEx ia IIC T6	Overspill protection to WHG	
H	ATEX II 3 G EEx nA II T6	Overspill protection to WHG	
R	For non-hazardous areas		
Y	Special version		
1	ATEX II 1/2 G EEx ia IIB T6		
2	ATEX II 1/2 G EEx ia IIB T6	Overspill protection to WHG	
5	ATEX II 1/2 G EEx ia IIC* T6	Overspill protection to WHG	
6	ATEX II 1/2 G EEx ia IIC* T6		
7	ATEX II 3 G EEx nA II* T6		
	*) With note: "Avoid electrostatic charge"		
20	Electronic insert	Additional weight	
A	Electronic insert not selected		--
B	with EC 61 Z 3-wire insert		0,2 kg
C	with EC 11 Z 3-wire Tx 33 kHz		0,2 kg
D	with EC 72 Z 3-wire Tx 1 MHz		0,2 kg
E	with EC 17 Z 2-wire PFM		0,2 kg
F	with EC 16 Z 2-wire PFM		0,2 kg
G	with EC 27 Z 2-wire PFM		0,2 kg
H	with EC 37 Z 2-wire PFM Tx 33 kHz		0,2 kg
I	with EC 47 Z 2-wire PFM Tx 1 MHz		0,2 kg
Y	Special version		
30	Process connection, material		
AE1	2" 150 lbs	RF Flange ANSI B16.5	steel 1,6 kg
AE2	2" 150 lbs	RF Flange ANSI B16.5	316Ti 1,6 kg
AE3	2" 150 lbs	RF Flange ANSI B16.5	PTFE >316Ti 1,6 kg
AE4	2" 150 lbs	RF Flange ANSI B16.5	Alloy B >316Ti 1,8 kg
AE5	2" 150 lbs	RF Flange ANSI B16.5	Alloy C >316Ti 1,8 kg
AE6	2" 150 lbs	RF Flange ANSI B16.5	Monel >316Ti 1,8 kg
AG2	2" 300 lbs	RF Flange ANSI B16.5	316Ti 3,0 kg
AL1	3" 150 lbs	RF Flange ANSI B16.5	steel 3,2 kg
AL2	3" 150 lbs	RF Flange ANSI B16.5	316Ti 3,2 kg
AL3	3" 150 lbs	RF Flange ANSI B16.5	PTFE >316Ti 3,2 kg
AN2	3" 300 lbs	RF Flange ANSI B16.5	316Ti 5,6 kg
AP1	4" 150 lbs	RF Flange ANSI B16.5	steel 5,4 kg
AP2	4" 150 lbs	RF Flange ANSI B16.5	316Ti 5,4 kg
AP3	4" 150 lbs	RF Flange ANSI B16.5	PTFE >316Ti 5,4 kg
AP4	4" 150 lbs	RF Flange ANSI B16.5	Alloy B >316Ti 5,8 kg
AP5	4" 150 lbs	RF Flange ANSI B16.5	Alloy C >316Ti 5,8 kg
AP6	4" 150 lbs	RF Flange ANSI B16.5	Monel >316Ti 5,8 kg
AR2	4" 300 lbs	RF Flange ANSI B16.5	316Ti 7,3 kg
AU2	6" 150 lbs	RF Flange ANSI B16.5	316Ti
AW2	6" 300 lbs	RF Flange ANSI B16.5	316Ti
BG1	DN 50 PN 25/40 B	Flange DIN 2527	steel 3,0 kg
BG2	DN 50 PN 25/40 B	Flange DIN 2527	316Ti 3,0 kg
BG3	DN 50 PN 25/40	Flange DIN 2527	PTFE >316Ti 3,0 kg
BM1	DN 80 PN 10/16 B	Flange DIN 2527	steel 4,5 kg
BM2	DN 80 PN 10/16 B	Flange DIN 2527	316Ti 4,5 kg
BM3	DN 80 PN 10/16	Flange DIN 2527	PTFE >316Ti 4,5 kg
BQ1	DN 100 PN 10/16 B	Flange DIN 2527	steel 5,4 kg
BQ2	DN 100 PN 10/16 B	Flange DIN 2527	316Ti 5,4 kg
BQ3	DN 100 PN 10/16	Flange DIN 2527	PTFE >316Ti 5,4 kg
CG2	DN 50 PN 25/40 C	Flange DIN 2527	316Ti 3,0 kg
CG4	DN 50 PN 25/40	Flange DIN 2527	Alloy B >316Ti 3,2 kg
CG5	DN 50 PN 25/40	Flange DIN 2527	Alloy C >316Ti 3,2 kg
CG6	DN 50 PN 25/40	Flange DIN 2527	Monel >316Ti 3,2 kg
CM2	DN 80 PN 10/16 C	Flange DIN 2527	316Ti 4,5 kg

30		Process connection, material							
		CM4	DN 80	PN 10/16	Flange DIN 2527	Alloy B	>316Ti	4,8 kg	
		CM5	DN 80	PN 10/16	Flange DIN 2527	Alloy C	>316Ti	4,8 kg	
		CM6	DN 80	PN 10/16	Flange DIN 2527	Monel	>316Ti	4,8 kg	
		CQ2	DN 100	PN 10/16 C	Flange DIN 2527	316Ti		5,4 kg	
		CQ4	DN 100	PN 10/16	Flange DIN 2527	Alloy B	>316Ti	5,8 kg	
		CQ5	DN 100	PN 10/16	Flange DIN 2527	Alloy C	>316Ti	5,8 kg	
		CQ6	DN 100	PN 10/16	Flange DIN 2527	Monel	>316Ti	5,8 kg	
		FG2	DN 50	PN 40 F	Flange DIN 2512	316Ti		3,0 kg	
		FM2	DN 80	PN 16 F	Flange DIN 2512	316Ti		4,5 kg	
		FQ2	DN 100	PN 16 F	Flange DIN 2512	316Ti		5,4 kg	
		GN1	1 1/2" NPT		Thread ANSI	steel		--	
		GN2	1 1/2" NPT		Thread ANSI	316Ti		--	
		GN4	1 1/2" NPT		Thread ANSI	Alloy B		--	
		GN5	1 1/2" NPT		Thread ANSI	Alloy C		--	
		GN6	1 1/2" NPT		Thread ANSI	Monel		--	
		GRB	G 1 1/2 A		Thread ISO 228	PP		--	
		GR1	G 1 1/2 A		Thread ISO 228	steel		--	
		GR2	G 1 1/2 A		Thread ISO 228	316Ti		--	
		GR4	G 1 1/2 A		Thread ISO 228	Alloy B		--	
		GR5	G 1 1/2 A		Thread ISO 228	Alloy C		--	
		GR6	G 1 1/2 A		Thread ISO 228	Monel		--	
		KF1	20 K 50 A		RF Flange JIS B2210	steel		2,6 kg	
		KF2	20 K 50 A		RF Flange JIS B2210	316Ti		2,6 kg	
		KF4	20 K 50 A		RF Flange JIS B2210	Alloy B	>316Ti	2,8 kg	
		KF5	20 K 50 A		RF Flange JIS B2210	Alloy C	>316Ti	2,8 kg	
		KF6	20 K 50 A		RF Flange JIS B2210	Monel	>316Ti	2,8 kg	
		ME2	DN 50	PN 40	DIN 11851	304		0,5 kg	
			Hygienic connection						
		NG2	DN 50	PN 40 N	Flange DIN 2512	316Ti		3,0 kg	
		NM2	DN 80	PN 16 N	Flange DIN 2512	316Ti		4,5 kg	
		NQ2	DN 100	PN 16 N	Flange DIN 2512	316Ti		5,4 kg	
		TE2	DN 40-51 (2")		Tri-Clamp connection	304		0,5 kg	
		YY9	Special version						
40		Inactive length L3, material							
		A	Inactive section not selected						--
		C mm (100 mm ... 4000 mm)				316Ti		0,2 kg/100 mm
		D mm (100 mm ... 4000 mm)				Alloy B		0,2 kg/100 mm
		E mm (100 mm ... 4000 mm)				Alloy C		0,2 kg/100 mm
		F mm (100 mm ... 4000 mm)				Monel		0,2 kg/100 mm
		H mm (125 mm ... 2000 mm)				fully insulated		0,1 kg/100 mm
		Y	Special version						
50		Active guard build-up compensation							
		1	Active guard not selected						--
		3	150 mm				316Ti		0,5 kg
		4	150 mm				Alloy B		0,6 kg
		5	150 mm				Alloy C		0,6 kg
		6	150 mm				Monel		0,6 kg
		9	Special version						
60		Probe length L, material							
		A mm (420 mm ... 24000 mm)				316Ti	PE insulated	0,04 kg/m
		B mm (420 mm ... 24000 mm)				316Ti	FEP insulated	0,04 kg/m
		C mm (420 mm ... 24000 mm)				316Ti	PFA insulated	0,04 kg/m
		D mm (420 mm ... 24000 mm)				Alloy C	PE insulated	0,04 kg/m
		E mm (420 mm ... 24000 mm)				Alloy C	FEP insulated	0,04 kg/m
		F mm (420 mm ... 24000 mm)				Alloy C	PFA insulated	0,04 kg/m
		Y	Special version						
65		Tensioning weight, fully insulated							
		1	Weight without anchoring hole						0,3 kg
		2	Weight with anchoring hole						0,3 kg
		9	Special version						

70										Option		
										1	Basic version	--
										2	Temperature spacer	0,5 kg
										3	Gas-tight probe seal	0,5 kg
										9	Special version	

80										Housing, Cable Entry					
										C	Aluminium	E-Housing	NPT 1/2"	IP66	--
										D	Aluminium	E-Housing	G 1/2 A	IP66	--
										E	Aluminium	E-Housing	M 20x1,5	IP66	--
										F	Aluminium	E-Housing	HNA 24x1,5	IP66	--
										J	316Ti	E-Housing	HNA 24x1,5	IP66	0,7 kg
										L	Polyester	E-Housing	NPT 1/2"	IP66	--
										M	Polyester	E-Housing	G 1/2 A	IP66	--
										O	Polyester	E-Housing	M 20x1,5	IP66	--
										P	Polyester	E-Housing	HNA 24x1,5	IP66	--
										T	Ctd. aluminium	E-Housing	NPT 1/2"	IP66	--
										U	Ctd. aluminium	E-Housing	G 1/2 A	IP66	--
										V	Ctd. aluminium	E-Housing	M 20x1,5	IP66	--
										W	Ctd. aluminium	E-Housing	HNA 24x1,5	IP66	--
										9	Special version				

										Complete product designation			
--	--	--	--	--	--	--	--	--	--	------------------------------	--	--	--



Note!
Please state lengths for the probe when ordering.
See also dimensioned drawings on Pages 6 and 7.

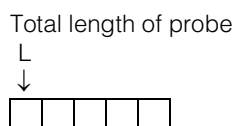
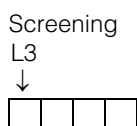

from the sealing surface of the process connection

Accessories

- Protective cover for the probe housing
Order No. 917 410-0000
- Rope shortening kit for standard probes
Material: PTFE
Max. operating temperature: 100 °C
Order No. 935598-0000
- Rope shortening kit for probes designed for use in explosion hazardous areas
Material: PTFE
Max. operating temperature: 100 °C
Order No. 935598-0001

Supplementary Documentation

Technical Information (TI)

- Electronic Inserts EC 11 Z, EC 72 Z
TI 270F/00/en
- Electronic Insert EC 16 Z
TI 170F/00/en
- Electronic Insert EC 17 Z
TI 268F/00/en
- Electronic Inserts EC 37 Z, EC 47 Z
TI 271F/00/en
- Electronic Insert EC 61 Z
TI 267F/00/en
- Probe Accessories
TI 229F/00/en
- Separate housing for electronic insert
TI 228F/00/en

Transmitters for limit detection and continuous level measurement on request

Operating Instruction (BA)

- Rope shortening kit
BA 126F/00/en

Endress+Hauser GmbH+Co.

Instruments International
P.O. Box 2222
D-79574 Weil am Rhein
Germany

Tel. (07621) 975-02
Tx 773926
Fax (07621) 975 345
e-mail: info@ii.endress.com

Internet:

<http://www.endress.com>

Endress + Hauser

The Power of Know How

