

Level Measurement *Silometer FMX 570*

Measurement of liquids and bulk solids
Suitable for explosion hazardous areas
For use with capacitance and hydrostatic probes



The Silometer FMX 570
installed in a Monorack
housing

Application

Used in combination with capacitance probes or hydrostatic sensors, the Silometer FMX 570 transmitter continuously measures the level of liquids, bulk solids, pastes and sludge:

- for capacitance probes, in conducting and non-conducting liquids and solids
- for hydrostatic sensors, in vented or open tanks.

Features and Benefits

- Intrinsically safe with certificate for [Ex ia] IIC (in preparation)
- 19" plug-in card for installation in Monorack housing or Racksyst assembly rack
- Can be calibrated for hydrostatic measurement without the need to fill the vessel
- Linearisation function for volume measurement in horizontal cylinders or tanks with conical outlet
- Standard current and voltage outputs
- Self-monitoring with immediate indication of fault condition

Endress + Hauser

The Power of Know How



Measurement System

Measurement system for liquids and bulk solids

- 1) Capacitance probe or top-mounted Deltapilot S
- 2) Side-mounted Deltapilot S
- 3) Capacitance probe

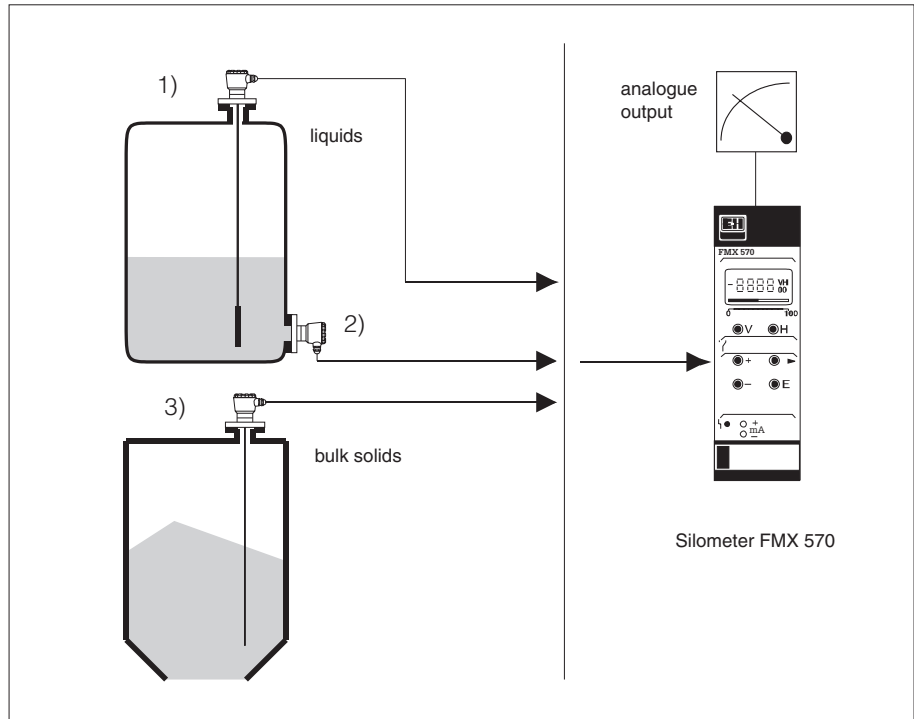

Measurement System

The measurement system comprises:

- Silometer FMX 570 transmitter
- Capacitance probe or Deltapilot S hydrostatic probe
- electronic insert EC 37/47 Z for capacitance probes or FEB 17/17 P for hydrostatic probes.

Output Signals

The Silometer FMX 570 offers:

- standard 0/4...20 mA and
- 0/2...10 V analogue signal

proportional to level or volume. The start and end of range values can be set as required.

Signal Input Circuit

A two-wire cable connects the probe or sensor to the Silometer transmitter. The Silometer supplies the power and the sensor returns an interference-free pulse frequency modulated signal proportional to capacitance or pressure. The intrinsically safe signal input is electrically isolated from the transmitter supply and the outputs. The measured value obtained from the signal is then displayed at the transmitter.

Self-Monitoring Function

The Silometer FMX 570 continuously monitors all signal lines from sensor to analogue outputs and gives an alarm if a fault is detected.

- An alarm relay with potential-free changeover contacts de-energises on fault condition (fail safe)
- The analogue signal switches to -10%, +110% or holds the last measured value

Volume measurement in a vessel with conical outlet. Up to 30 level and volume values can be entered in the linearisation table.

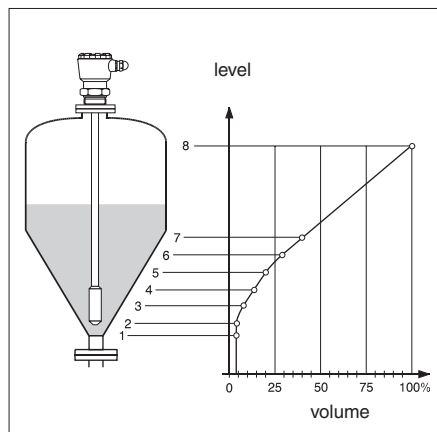

Linearised Volume Measurement

For tanks with conical outlets, a volume measurement with linearised current output can be obtained by entering a vessel characteristic. The most common shape, a horizontal cylinder is programmed as a standard feature.

Measurement Principle

Schematic diagram of capacitance measurement in non-conducting media

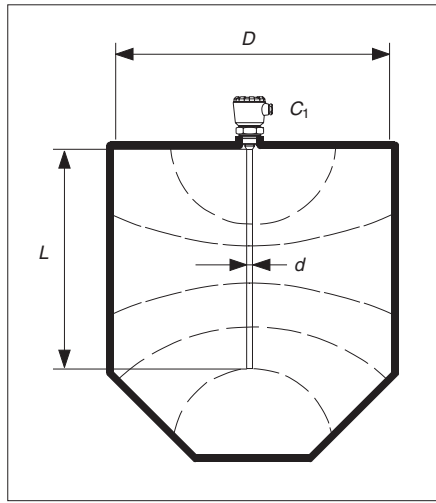

Capacitance Measurement

The probe and vessel form the two plates of a capacitor, the total capacitance being:

$$C_{tot} = C_1 + \frac{2\pi\epsilon_0\epsilon_r L}{\ln \frac{D}{d}}, \quad (1)$$

whereby

- C_1 = capacitance of feed through,
- ϵ_0 = dielectric constant of vacuum,
- ϵ_r = relative dielectric constant of product,
- D = diameter of vessel,
- d = diameter of probe,
- L = length of probe immersed in product.

Schematic diagram of capacitance measurement in electrically conducting media

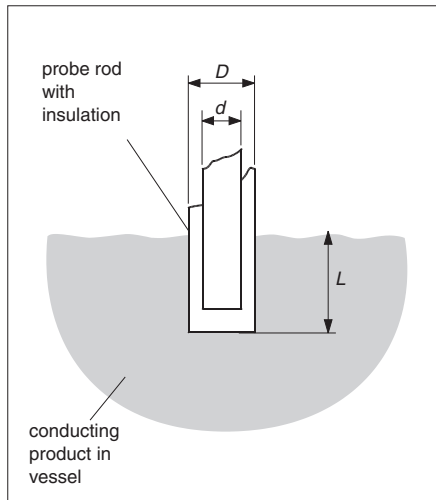

Measurement in Conducting Media

If the product conducts, the capacitance is determined by the thickness and properties of the insulating material surrounding the probe. Equation (1) applies, whereby the variable D is now the diameter of the probe with insulation.

Measurement is independent of dielectric constant and not affected by changes in this variable.

Schematic diagram of hydrostatic level measurement principle

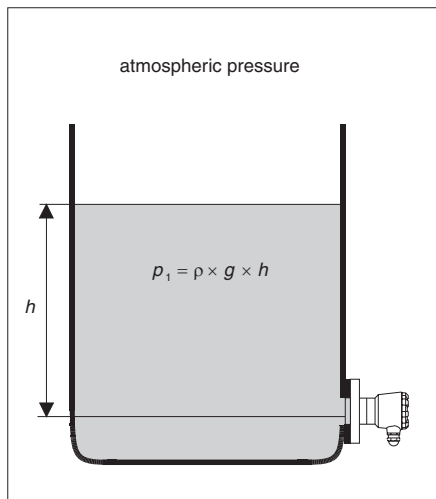

Hydrostatic Measurement

In an open vessel, the level is derived from the hydrostatic pressure exerted by a column of liquid on a probe placed at its foot. The pressure exerted is:

$$p_1 = \rho \times g \times h, \quad (2)$$

whereby

- p_1 = hydrostatic pressure,
- ρ = density of the liquid,
- g = acceleration due to gravity,
- h = height of the liquid column.

Assuming a constant density, the level of the liquid can be calculated from the pressure measured by the Deltapilot S.

Installation

Mounting

Racksyst plug-in cards must be installed outside explosive hazardous areas in a rack or protective housing.

Endress+Hauser can provide the following alternatives:

- 19" rack (84 HP wide) for mounting up to 12 Silometers in the control room
- Half 19" wide field housing with Protection IP65
- Monorack housing (7 HP) for single or multiple mounting in the control panel.

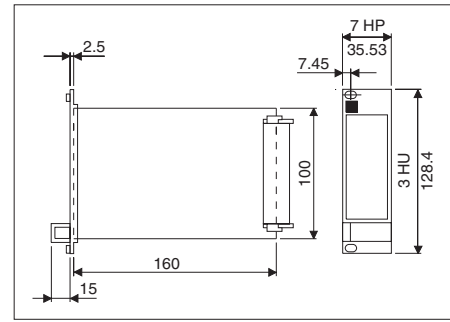

Dimensions [mm]
FMX 570 plug-in card



Monorack housing

Plug-In Card

- Format: Racksyst card to DIN 41494 (Europa card, see diagram)
- Front panel: black synthetic with inlaid blue field, with grip and label area
- Protection to DIN 40050: Front panel IP20, card IP00
- Weight: approx. 0.3 kg
- Electromagnetic compatibility Interference emission to EN 61326, Electrical Equipment Class A Interference immunity to EN 61326
- Operating temperature: 0 °C...+70 °C Storage temperature: -20 °C...+85 °C

Additional Instrumentation

The negative terminals of the output signals and 24 V supply are connected to the circuit zero of the Silometer.

- For instruments with a non-isolated input (e.g. HTA 470 Z): only one instrument can be directly connected to the current output
- Several instruments can be connected to the voltage output in parallel, if their potentials are all related to the negative terminal of the 24 V supply
- There is no restriction on potential-free instruments, except for the minimum or maximum load.

Sensor Connection

The instrument is suitable for use in industrial environments.

- Use two-core installation cable, max. resistance 25 Ω per core
- Use shielded cable, where possible grounded at both ends, if heavy electromagnetic interference is to be expected.
- Note local regulations when laying cable in hazardous areas.

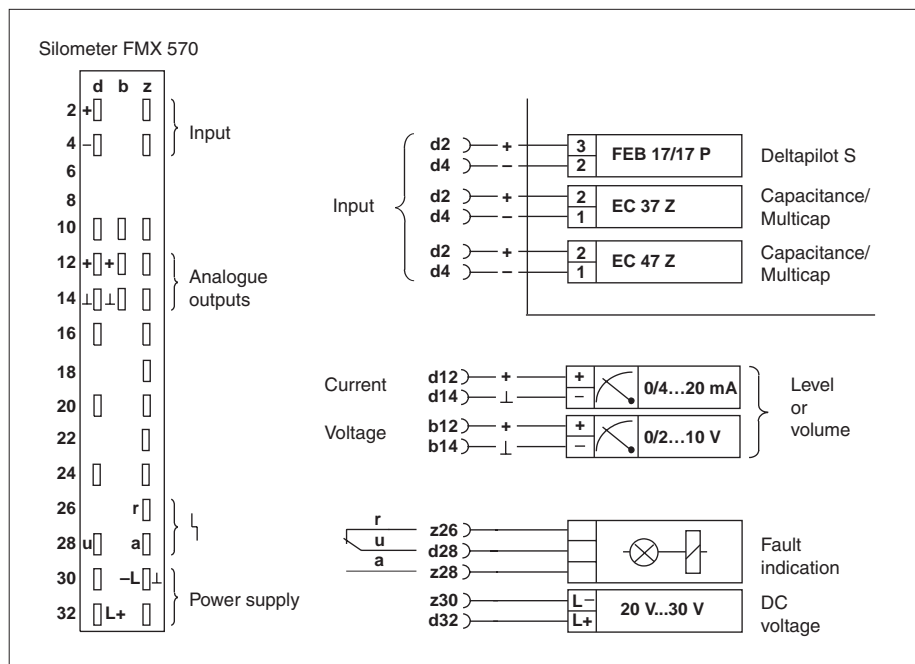

Connection diagram
Silometer FMX 570

Operation

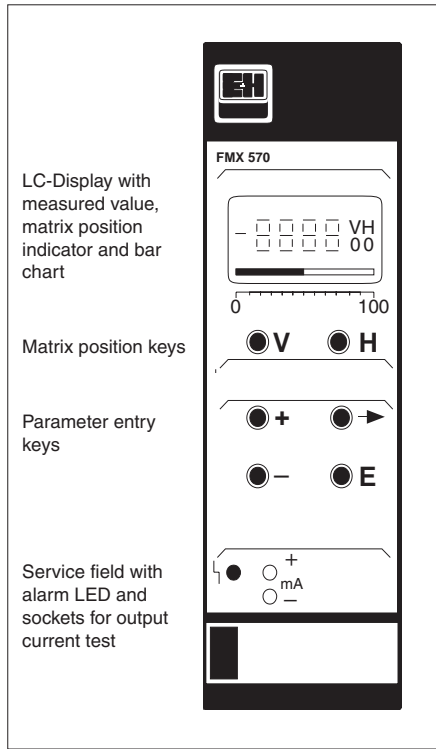

Front panel of Silometer FMX 570

Configuration at Front Panel

Silometer FMX 570 transmitters are configured at the front panel.

- Six keys access a parameter matrix, defined by a vertical (V) and horizontal (H) position, in which relevant data can be entered
- The selected matrix field and parameter are indicated in the LC-display
- A continuous display of level, volume etc. is available during operation
- A horizontal 10-step LCD bar strip indicates level or volume as a function of the analogue output.

Operational Status

The operational status of the transmitter is indicated by means of the red LED in the diagnostics field which:

- flashes to indicate a warning or
- lights for a fault condition.

Diagnosis

There are two possibilities for on-line diagnosis:

- an error code can be read from the matrix position V9H0
- the current output can be monitored at the sockets on the front panel – analogue signals can also be simulated to check connected instrumentation.

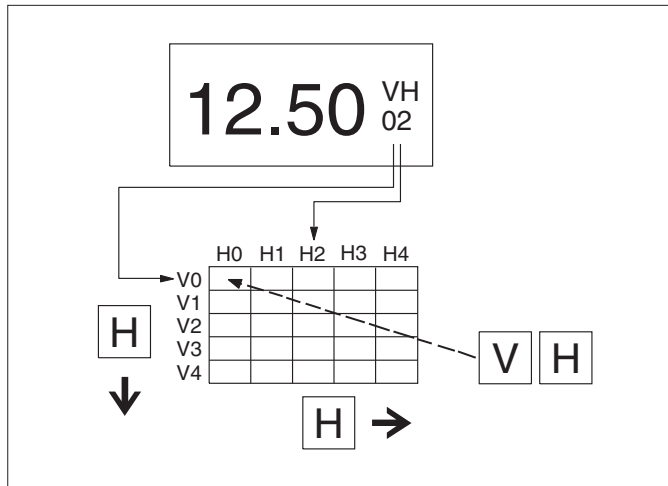

Operating matrix. The parameter fields are selected by the "V" and "H" keys.

Operating Matrix

The Silometer FMX 570 is operated by means of a 10x10 matrix:

- each row governs a particular function
- each field sets one parameter

The same operating philosophy is implemented in all Endress+Hauser instruments, so that a user familiar with one type can quickly configure another.

Technical Data

Plug-In Connection

- Multipoint strip conforming to DIN 41612, part 3, Type F (28-pole)
- Coding pins in strip: Positions 2 and 9

Power Supply

- DC voltage: 24 V (20 V...30 V)
Residual ripple $U_{\sim pp}$: 2 V within voltage tolerance
- Current: approx. 90 mA, max. 125 mA
Integral fine-blow fuse

Signal Inputs

- Intrinsically safe [Ex ia] IIC or IIB, electrically isolated from the rest of the circuitry
- Sensors:
Capacitance or Multicap probes with EC 37 Z or EC 47 Z electronic inserts
Deltapilot S with FEB 17 or FEB 17 P electronic inserts

Signal Outputs

- Current output:
0...20 mA/4...20 mA selectable,
 R_L max. 500 Ω
- Voltage output:
0...10 V/2...10 V selectable
 R_L min. 10 k Ω
- Fault alarm: relay with potential-free change-over contact; switching capacity: max. 2.5 A, max. 250 V AC, max. 300 VA at $\cos \varphi > 0.7$
max. 100 V DC, max. 90 W

Certificates

- TÜV 00 ATEX 1640
XA 109F/00/a3
- WHG: Z-65.13-107 (Germany)
ZE 210F/00/de
- WHG: Z-65.11-29 (Germany)
ZE 189F/00/de

Product Designation

Silometer FMX 570

Product Code FMX 570-A0E11

Supplementary Documentation

- Racksyst Planning Hints
Technical Information TI 224F/00/en
- Monorack II
Technical Information TI 183F/00/en
- Deltapilot S
System Information SI 026F/00/en
- Electronic Inserts FEB 11/17 (P)
Operating Instruction KA 048F/00/a3
- Multicap DC 11
Technical Information TI 169F/00/en
- Multicap DC 16
Technical Information TI 096F/00/en
- Multicap DC 21
Technical Information TI 208F/00/en
- Multicap DC 26
Technical Information TI 209F/00/en
- Multicap DC 11, 16, 21, 26 AN/AS
Technical Information TI 243F/00/en
- Multicap DC 11, 16, 21, 26 EN/ES
Technical Information TI 242F/00/en
- Multicap T DC 12 TA
Multicap T DC 11, 16, 21, 26 TAN/TAS
Technical Information TI 239F/00/en
- Multicap T DC 12 TE
Multicap T DC 11, 16, 21, 26 TEN/TES
Technical Information TI 239F/00/en
- Electronic Inserts EC 37 Z, EC 47 Z
Technical Information TI 271F/00/en

Endress+Hauser
GmbH+Co. KG
Instruments
International
P.O. Box 2222
D-79574 Weil am Rhein
Germany

Tel. (07621) 975-02
Fax (07621) 975-345
<http://www.endress.com>
info@ii.endress.com

Endress + Hauser
The Power of Know How

