

# Capacitance Limit Detection *nivocompact FTC 131/231/331*

## Compact level limit switches for bulk solids



### Applications

The Nivocompact FTC... is used for limit detection in silos containing bulk solids (for minimum or maximum level indication). Three versions cover almost any measuring application:

*FTC 131 with rod probe  $\varnothing$  25 mm,* for mounting laterally or from above. Mainly for maximum detection of fine-grained or powdery bulk solids. For minimum detection in small silos with light bulk solids. For use in the food processing industry.

*FTC 231 with rope probe  $\varnothing$  10 mm,* for mounting from above. Mainly for maximum detection. For minimum detection with light bulk solids.

*FTC 331 with rope probe  $\varnothing$  16 mm,* for mounting from above. For maximum and minimum detection with heavy bulk solids.



FTC 131

### Advantages:

- Complete unit consisting of probe with plug-in electronic insert:
  - simple mounting, low installation costs
  - for automation and control systems (PLC, PCS, PC, relays, contactors, etc.)
- No moving parts in silo:
  - no wear, long operating life
  - no maintenance
- Simple calibration:
  - variable switchpoint with probes mounted from above
- Rope version can be easily shortened:
  - can be used for various limit values
  - short delivery time

FTC 231



FTC 331



Endress + Hauser

The Power of Know How



## Application Examples

Sand	Glass aggregate
Gravel	Moulding sand
Lime	Ore, crushed
Plaster	Aluminium shavings
Cement	Grain
Pumice	Flour
Dolomite	Sugar beet chips
Kaolin	Fodder

and similar bulk solids

Note:  
Bulk solids should have dielectric constants  $\epsilon_r \geq 2.5$ .

## The Complete Measuring System

The Nivocompact is an electronic switch. The entire measuring system consists of:

- Nivocompact FTC...
- power supply and
- connected control systems, switches, signal transmitters (e.g. process control systems, PLC, relays, microcontactors, lamps, sirens etc.)

The capacitance level limit switches Nivocompact FTC 131...FTC 331 in practice

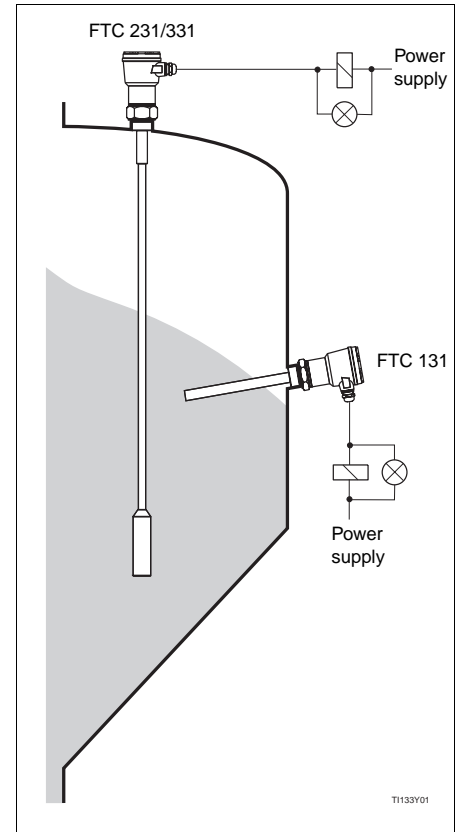

## Operation

The probe (rod or rope) and the silo wall form the two electrodes of a capacitor, with a high frequency voltage between them.

The limit value is based on the principle of a discharge circuit:

As long as the probe is in air with a dielectric constant of  $\epsilon_r = 1$ , then the discharge time constant is  $\tau = R \times C_A$  where R is the resistance of the circuit and  $C_A$  the capacitance of the capacitor formed by the probe and silo wall.

If bulk material with a high dielectric constant moves into the electrical field between the probe and silo wall, then the capacitance  $C_A$  increases and with it the time constant  $\tau$ .



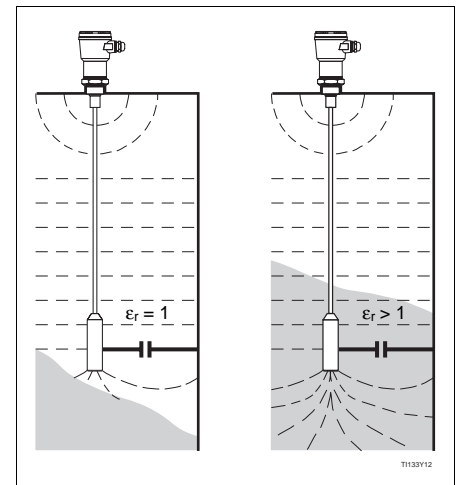

The change in the time constant is evaluated and the Nivocompact is activated according to its switching mode.

The capacitor consisting of the silo wall and probe

The Nivocompact is extremely insensitive to low build-up on the probe and silo wall as long as the material does not form a bridge between the probe and wall (e.g. on the threaded boss).

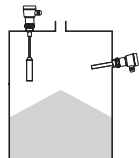

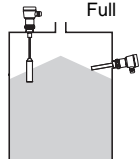
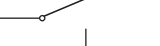
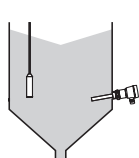
# Fail-Safe Mode

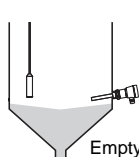
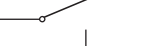
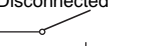
Safety Switching	Level	Electronic Switch
<b>Maximum fail-safe mode</b>		Connected  (load circuit closed)
		Disconnected  (load circuit open)
<b>Minimum fail-safe mode</b>		Connected  (load circuit closed)
		Disconnected  (load circuit open)
<b>Power failure</b>		Disconnected  (load circuit open)

T1133Y02

The electronic switch operates according to the fail-safe switching and the level.

The built-in feature for minimum/maximum fail-safe switching allows the Nivocompact to be used in all applications requiring high operational safety:

- **Maximum Fail-Safe:**  
The current circuit is blocked if the probe is covered or the power supply fails.

- **Minimum Fail-Safe:**  
The current circuit is blocked if the probe is uncovered or the power supply fails.

A red LED on the electronic insert indicates switching status.

## Main Features of the Different Electronic Inserts

**Electronic Insert EC 20**  
Two-wire AC connection  
21 V...250 V  
Electronic switch, max. 350 mA

**Electronic Insert EC 23**  
Three-wire DC connection  
10 V...55 V  
Transistor circuit,  
load connection NPN, max. 350 mA

**Electronic Insert EC 22**  
Three-wire DC connection  
10 V...55 V  
Transistor circuit,  
load connection PNP, max. 350 mA

**Electronic Insert EC 24**  
with potential-free relay output,  
AC voltage operation  
21 V...250 V or  
DC voltage operation  
20 V...200 V

Electrical connections available with the different electronic inserts.

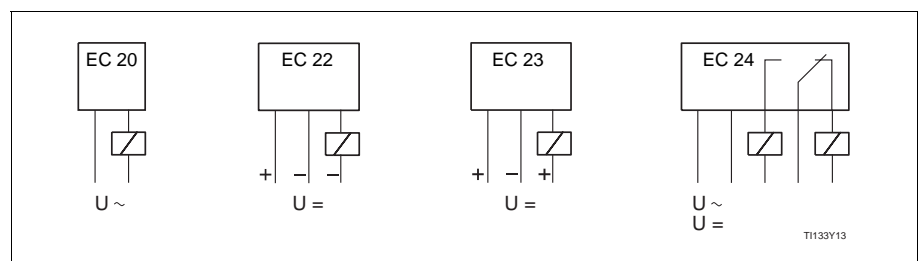

# Basic Differences Between Probes

## Nivocompact FTC 131

Rod probe,  $\varnothing$  25 mm  
Insulation PE  
Probe length 350 mm

## Nivocompact FTC 231

Rope probe,  $\varnothing$  10 mm  
Insulation PA  
Probe length max. 22 m  
Tensile load max. 3 t

## Nivocompact FTC 331

Rope probe,  $\varnothing$  16 mm  
Insulation PVC  
Probe length max. 22 m  
Tensile load max. 8 t

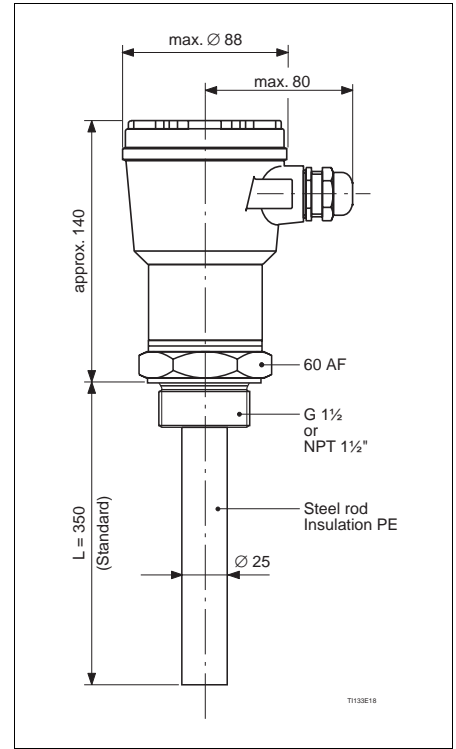

Dimensions FTC 131

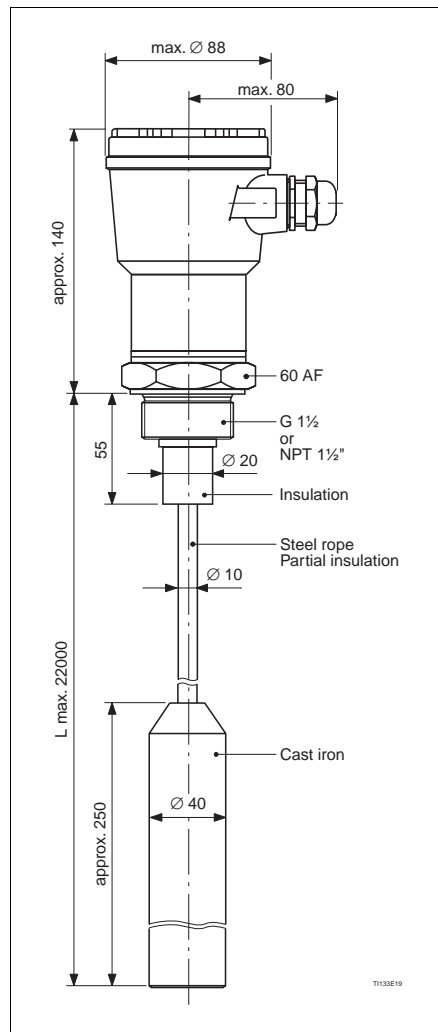

Dimensions FTC 231

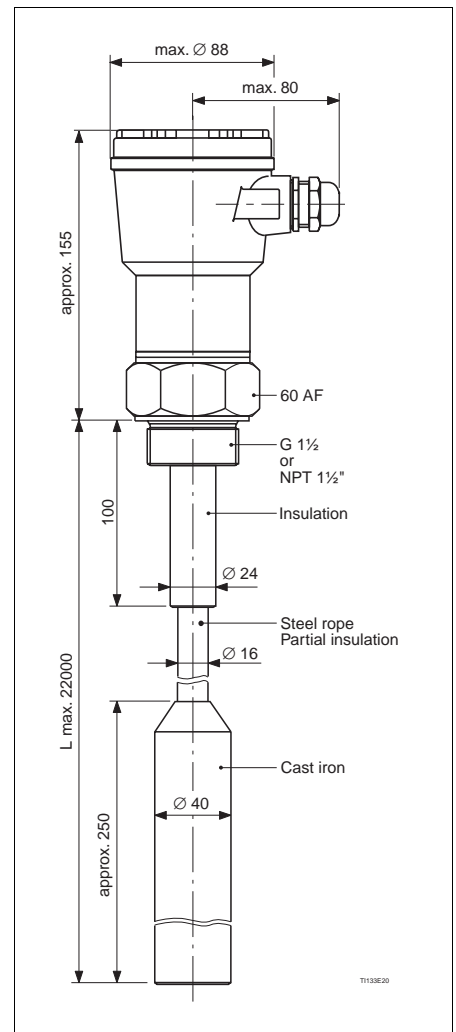

Dimensions FTC 331

# Installation

## General Information

### Filling the Silo

The filling stream should not be directed onto the probe.

### Angle of Material Flow

Note the angle of material flow or the outlet funnel when determining the measuring point or probe length.

### Distance Between Probes

If more than one probe is mounted in a silo, then a minimum distance of 0.5 m must be allowed for in order to avoid mutual interference.

### Threaded Socket for Mounting

Use the shortest possible threaded socket when mounting the Nivocompact FTC 131...331.

Condensation can form in long threaded sockets and interfere with correct operation of the probe.

### Heat Insulation

With high silo temperatures:

Insulate the outside silo wall to avoid exceeding the max. permissible temperature of the Nivocompact housing. This insulation also prevents condensation near the threaded boss and so reduces build-up and the danger of error switching.

### Installation in the Open

A protective sun cover as an accessory protects the Nivocompact with the aluminium housing from excessive temperatures and from condensation which may form in the housing due to large temperature variations.

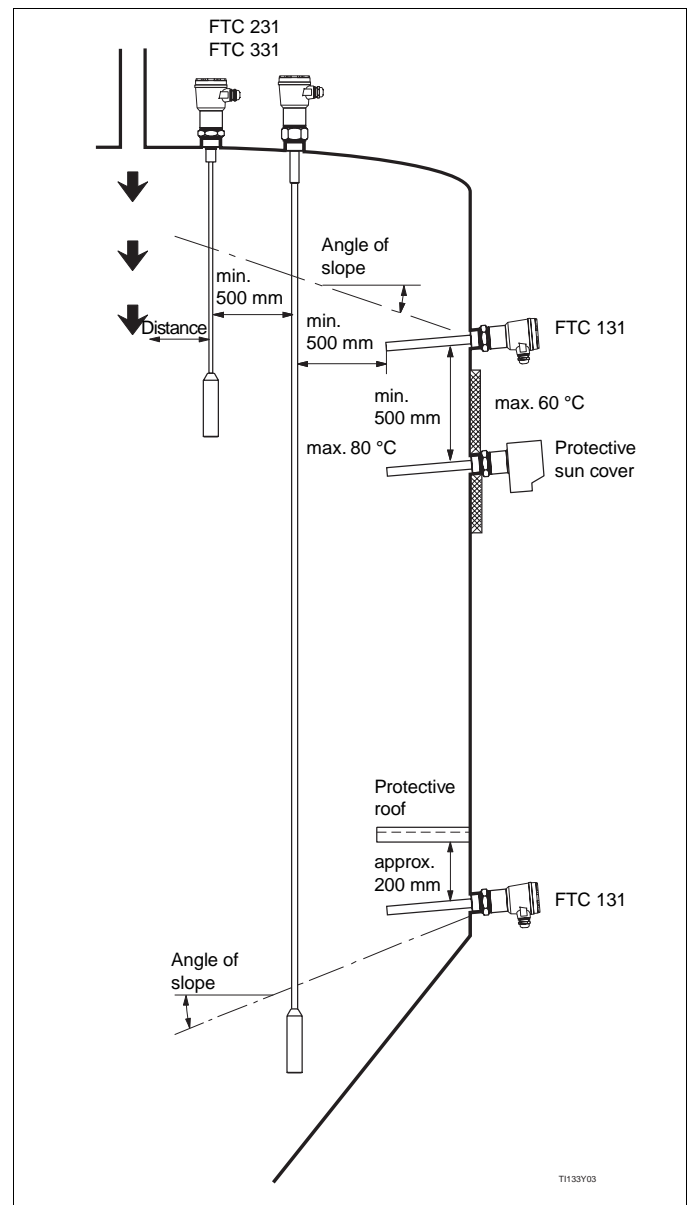

General information for installing the capacitance Nivocompact FTC... level limit switch.

# Project Planning Nivocompact FTC 131

Silo with metal walls

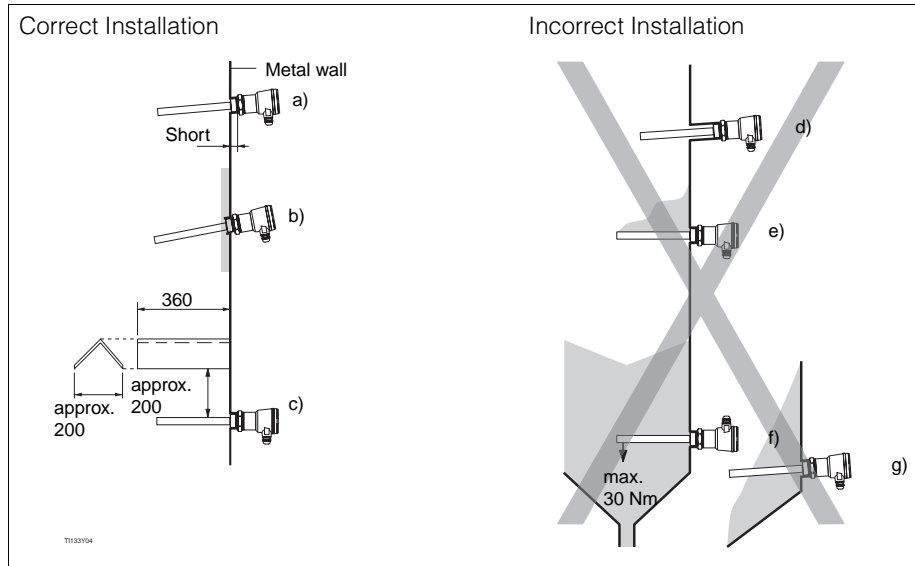

- a) Maximum level detection; Short threaded socket (ideally 25 mm = half standard length socket).
- b) Light build-up on silo wall: threaded socket welded internally. The probe tip points slightly downwards so that material falls off more easily.
- c) Protective roof to protect against collapsing mounds or high strain on the rod probe caused by the material filling curtain with the Nivocompact FTC 131 used for minimum detection.

- d) Threaded socket too long. Material can settle and lead to error.
- e) Error switching caused by high build-up on the silo wall is best avoided by mounting the Nivocompact FTC 231 or FTC 331 with rope probe in the roof of the silo.
- f) High strain on the rod probe due to material run-out; The Nivocompact FTC 431 with disk probe is recommended. Cable gland pointed upwards can allow moisture to enter.
- g) In areas where material can settle, the instrument cannot recognise an »empty« silo. The FTC 231 or FTC 331 is recommended.

Silo with concrete walls

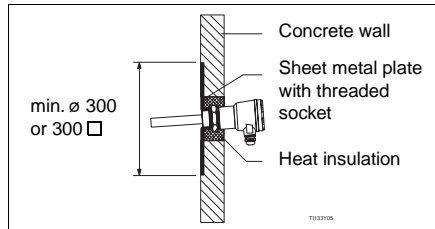

This mounting example shows a steel plate as counter electrode. Heat insulation prevents condensation and build-up on the steel plate.

Silo with plastic walls

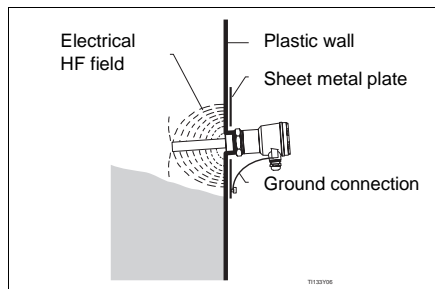

When mounting in a silo made of plastic material, a sheet metal plate should be attached to the outside of the silo as a counter electrode. This plate can be either square or round. The dimensions with thin silo walls and low dielectric constant should be approx. 0.5 m on each side or ø 0.5 m. This should be approx. 0.7 m along each side or ø 0.7 m for silos with thicker walls or for materials with higher dielectric constants.

For small differences in level

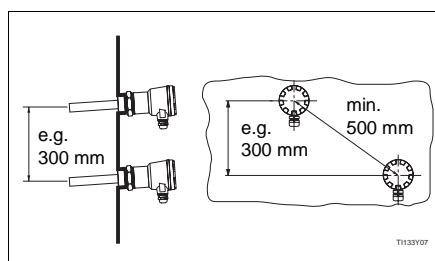

The minimum distance required can be maintained by staggered mounting.

# Project Planning Nivocompact FTC 231 and FTC 331

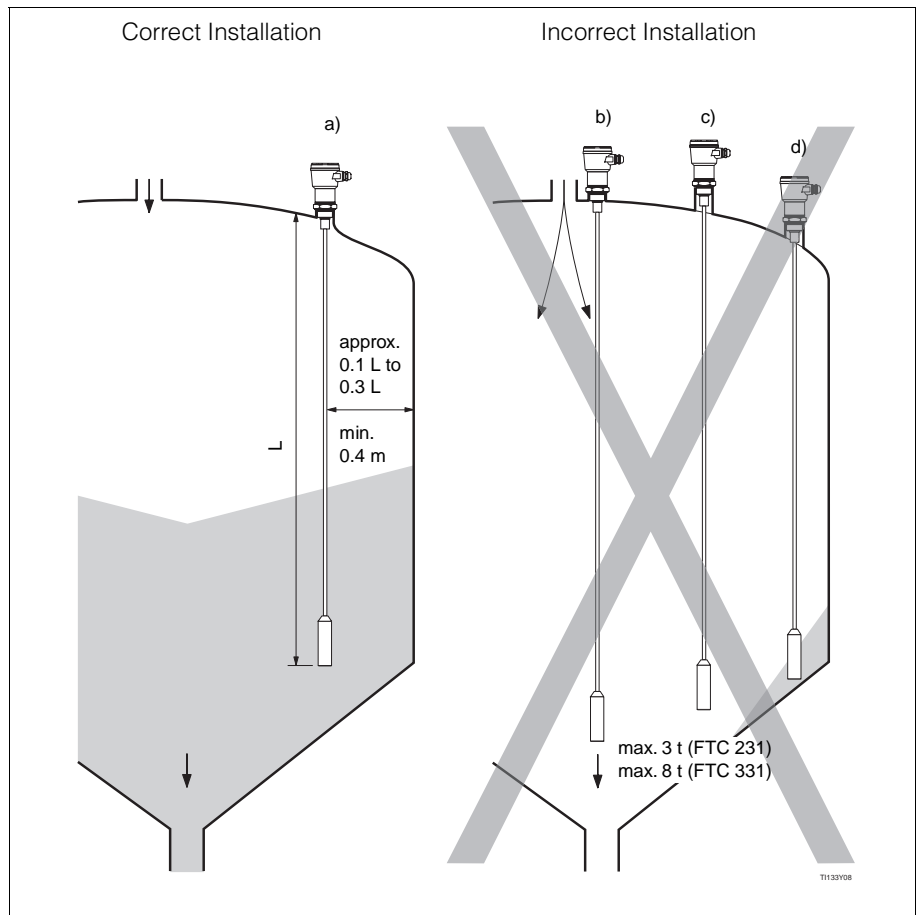

Silo with metal walls

a) The correct distance from the silo wall, the material filling curtain and the material outlet.  
For pneumatic filling systems, the distance of the probe from the wall should not be too small as the probe may swing against it.

b) The probe can be damaged by the inflowing material if mounted too near the inlet.  
When mounted near the centre of the outlet, the high tensile forces present at this point may damage the probe or subject the silo roof to excessive strain.

c) Threaded socket too long;  
Condensation and dust may penetrate and cause errors.

d) Too near silo wall;  
When swinging gently the probe can hit the wall or touch any build-up which may have formed.  
This can result in error switching

## Silo Roof

Ensure that the silo roof is strong enough!  
Very high tensile forces, up to 100.000 N (10 t) may occur at the material outlet especially with heavy, powdery bulk materials which tend to form build-up.

## Coarse Grained Materials

The Nivocompact FTC 231 or FTC 331 should only be used for maximum detection in silos with very coarse or abrasive material.

## Distance between Probes

A minimum distance of 0.5 m between probes must be maintained to ensure that there is no mutual interference; This also applies to all Nivocompact units which are mounted next to one another in silos with non-conducting walls.

Silo with concrete walls

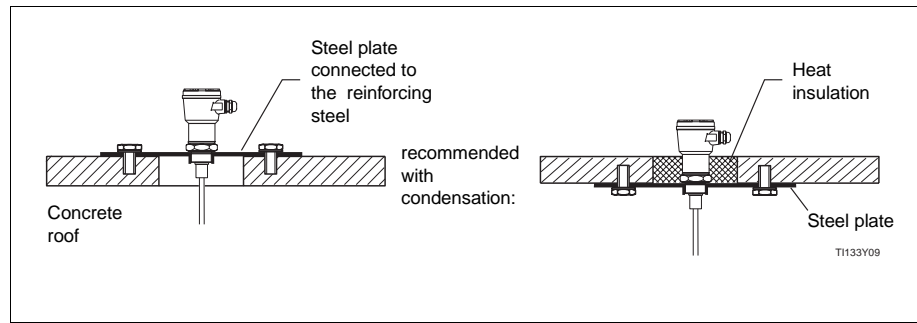

The 25 mm long threaded socket should project into the silo so as to minimise effects due to condensation and material build-up.

Heat insulation prevents condensation and build-up on the steel plate.

Silo with plastic walls

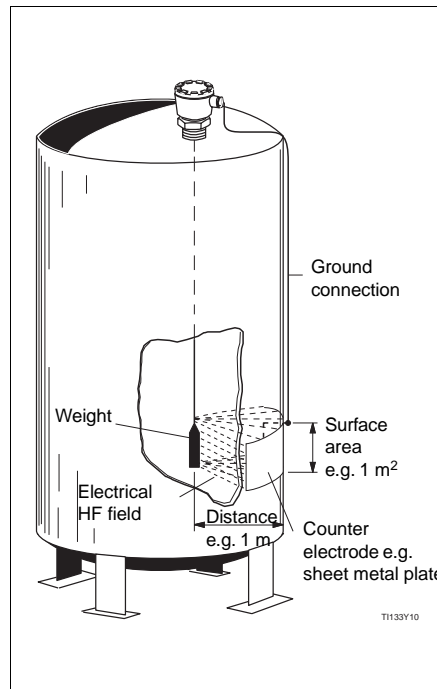

When mounting in a silo made of plastic, a counter electrode must be mounted on the outside and at the same height as the weight. The length of the edge of the counter electrode should be roughly the same length as the distance of the weight to the silo wall.

Different probe lengths

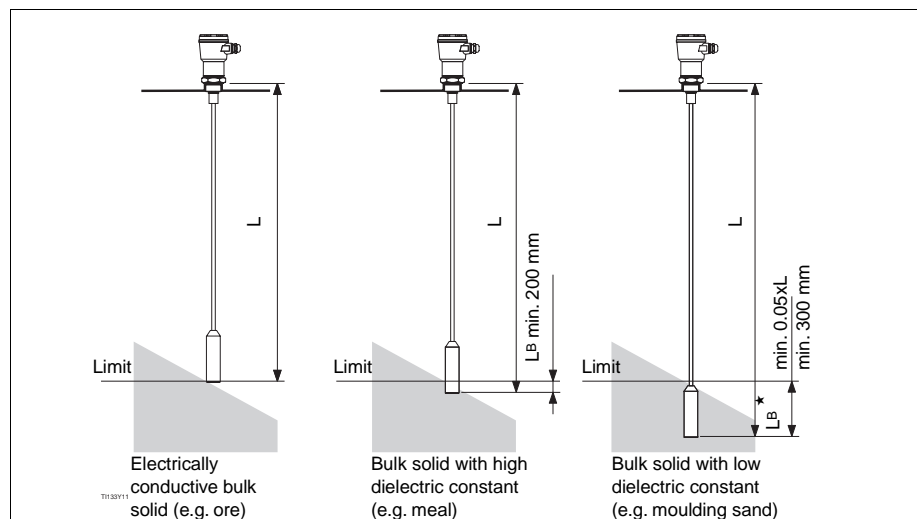

★  $L_B$  (covered length):

With non-conductive materials having low dielectric constants, the rope probe must be approx. 5 % (or minimum 300 mm) longer than the distance from the roof of the vessel to the switch point. If it is not possible to select the correct  $L_B$  for minimum detection with very long

probes then a special version with »butterfly weight« can be supplied as an accessory. The increased surface area of this weight ensures that there is a large enough change in capacitance when the probe is covered by material. An  $L_B$  of 300 mm is normally sufficient.



# Wiring Connections General Information

## Load Limit Values

Note the limit values of the loads to which you want to connect the Nivocompact. Exceeding the load can destroy the electronic insert (or the relay contact in the EC 24).

## Fuse

Ensure that the rating of the fine-wire fuse corresponds to the maximum load to be connected;  
the fine-wire fuse does not protect the electronic insert of the Nivocompact FTC.

## Diameter of Wiring

Because of the small currents used, only small diameter cabling is required. Low-cost cabling with diameters of 0.5 mm<sup>2</sup> to max. 1.5 mm<sup>2</sup> is recommended.

## Grounding

The Nivocompact must be grounded to give reliable operation free from interference. This is done by either connecting it to a grounded silo with metal or reinforced concrete walls or else to the earth conductor PE. If a counter electrode is connected to a silo made of plastic material then there must be a short ground connection from the Nivocompact to the counter electrode.

## Connecting the EC 20

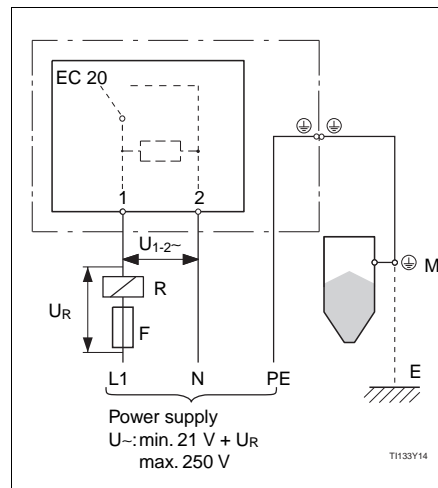

## Connecting the Nivocompact with Electronic Insert EC 20 for AC Voltage (Two-Wire Connection)

### Connecting in series to a load

The level limit switch Nivocompact with electronic insert EC 20 must - like all switches - be connected in series with the load (e.g. relays, microcontactors, lamps) to the power supply.

### Connection voltage

The voltage across Terminal 1 and 2 of the electronic insert must be at least 21 V.

The power voltage must be correspondingly higher to compensate for the voltage drop across the connected load.

### Load cutoff

Note that loads connected in series are not completely disconnected from the power supply if the electronic switch in the electronic insert of the Nivocompact »cuts off« (blocks) with the level alarm. Because of the current requirements of the electronics, a small »residual current« still flows through the external load.

When the load is a relay with a very small retaining current, then the relay may not de-energise. In this case connect an additional load in parallel to the relay, e.g. a resistor or signal lamp.

Connecting the Nivocompact with EC 20 electronic insert

- $U_{1-2}$ : 21 V... 250 V across Terminals 1 and 2 of the EC 20
- R: Connected (external) load ; e.g. relay
- F: Fine-wire fuse, load-dependent
- M: Ground connection to silo or to counter electrode
- E: Grounding
- $U_R$ : Voltage drop between the load R and the fine-wire fuse

## Connecting the EC 22, EC 23

Connecting the Nivocompact with electronic insert EC 22 PNP connection

- F: Fine-wire fuse, load-dependent
- R: Connected load, e.g. PLC, PCS, relay
- M: Ground connection to silo or to counter electrode
- E: Grounding

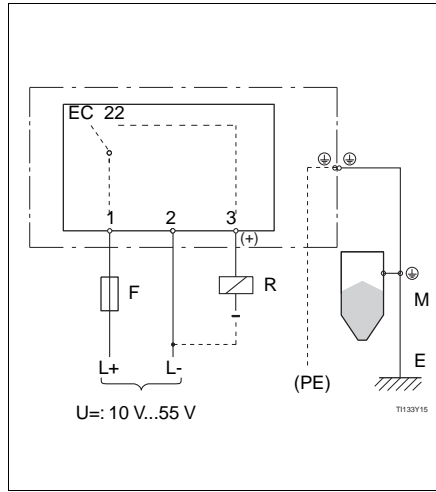

### Connecting the Nivocompact with Electronic Insert EC 22 (Three-Wire PNP) or Electronic Insert EC 23 (Three-Wire NPN) for DC Voltage

#### Transistor circuit for load

The load connected to Terminal 3 is switched by a transistor, contactless and therefore without bouncing.

EC 22:

Terminal 3 has a positive signal with normal switching.

EC 23:

Terminal 3 has a negative signal with normal switching.

The transistor is blocked on level alarm or with a power failure.

#### Protection against voltage peaks

Connecting to an instrument with a high inductance: a voltage limiter should be connected.

Connecting the Nivocompact with electronic insert EC 23 NPN connection

- F: Fine-wire fuse, load-dependent
- R: Connected load, e.g. PLC, PCS, relay
- M: Ground connection to silo or to counter electrode
- E: Grounding

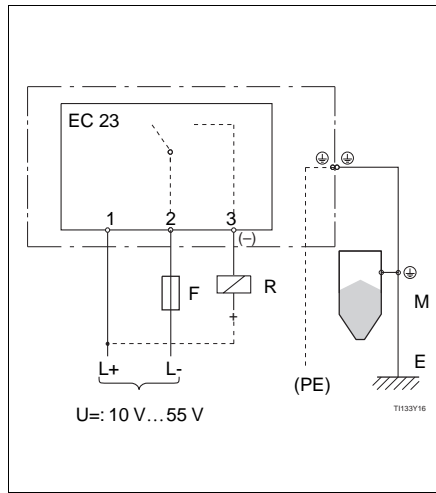

## Connecting the EC 24

Connecting the Nivocompact with electronic insert EC 24 Relay output

- F1: Fine-wire fuse 200 mA, semi-time lag recommended
- F2: Fine-wire fuse to protect the relay contact, load-dependent
- M: Ground connection to silo or to counter electrode
- E: Grounding

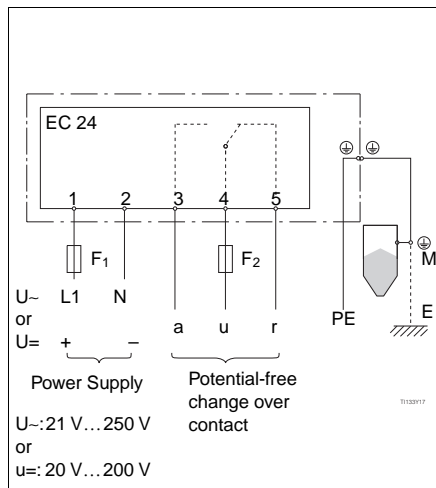

### Connecting the Nivocompact with Electronic Insert EC 24 (Relay Output) for DC and AC Voltages

#### Relay contact for load

The load is connected over a potential-free relay contact (change-over contact). The relay contact breaks the connection between Terminal 3 and Terminal 4 on level alarm or with a power failure.

#### Protection against voltage peaks and short-circuiting

Protect the relay contact by connecting a spark barrier to instruments with high inductance.

A fine-wire fuse (load-dependent) can protect the relay contact if a short-circuit occurs.

## Adjustment and Calibration Features

For calibrating, the Nivocompact should be adjusted to the capacitance value of the capacitor formed by the probe and wall of the silo.

You can also select the fail-safe mode required for your particular application.

Calibration with an empty silo requires less handling of the electronic insert.

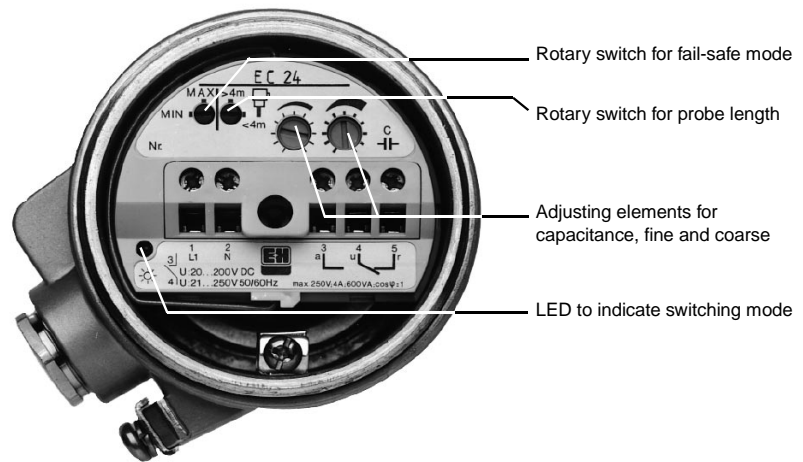

Operating elements on the electronic insert

## Technical Data

### Operating Data

Nivocompact	FTC 131	FTC 231	FTC 331
Operating temperature in silo	-20 °C... +80 °C	-20 °C... +80 °C	-20 °C... +60 °C
Operating pressure $p_{e_0}$ , according to operating temperature	max. 10 bar	atmospheric	atmospheric
Max. permissible load on probe	30 Nm lateral	30 kN vertical	80 kN vertical
Minimum dielectric constant $\epsilon_r$ of material	2.5		
Operating temperature for housing	-20 °C... +60 °C		
Storage temperature	-40 °C... +85 °C		

### Probes

Nivocompact	FTC 131	FTC 231	FTC 331
Material	Steel rod	Steel rope	Steel rope
Probe diameter	25 mm	10 mm	16 mm
Insulation	PE	PA	PVC
Thickness of insulation	3.5 mm	1 mm	2 mm
Electrical connection to bulk solid	Fully insulated	Steel rope connected to cast iron weight	

### Process connections

Parallel thread:  
G 1 1/2 A acc. to DIN ISO 228/1  
Tapered thread:  
NPT 1 1/2" acc. to ANSI B1.20.1  
Material:  
steel or  
stainless steel 1.4571

### Probe length tolerances:

Probe length	Tolerance
to 1 m	+0 mm, -5 mm
to 3 m	+0 mm, -10 mm
to 6 m	+0 mm, -20 mm
to 22 m	+0 mm, -30 mm

## Housing Versions



**A**  
Aluminium housing with  
standard cable gland  
PG 16,  
Protection IP 55

**B**  
Aluminium housing with  
water-tight cable gland  
PG 16,  
Protection IP 66

**R**  
Aluminium housing with  
synthetic coating, for  
aggressive  
atmospheres;  
with water-tight cable  
gland PG 16,  
Protection IP 66

**K**  
Synthetic housing in  
PBTP with water-tight  
cable gland PG 16,  
Protection IP 66

### Cable Gland

Housing IP 55: standard PG in  
nickel-plated brass with NBR seal for  
cable diameter 7...10 mm.

Housing IP 66: Water-tight PG in  
polyamide with Neoprene-CR seal for  
cable diameter 5...12 mm.

### Electronic Inserts

Terminal connections: for max. 2.5 mm<sup>2</sup>

Measuring frequency:  
approx. 750 kHz for short probes,  
up to 4 m, switchable to approx.  
450 kHz for long probes

Initial capacitance, adjustable:  
to approx. 400 pF

Switching delay: approx. 0.5 s

Minimum/Maximum Fail-Safe Switching:  
selectable with rotary switch

Switching indication: red LED

### Electronic Insert EC 20 for AC voltage (Two-wire Connection)

Power supply U<sub>~</sub>:  
21 V...250 V, 50/60 Hz

Connected loads, short-term  
(max. 40 ms): max. 1.5 A;  
max. 375 VA with 250 V;  
max. 36 VA with 24 V

Maximum voltage drop: 11 V

Connected loads, continuous:  
max. 350 mA;  
max. 87 VA with 250 V;  
max. 8.4 VA with 24 V

Minimum load current with 250 V:  
10 mA (2.5 VA)

Minimum load current with 24 V:  
20 mA (0.5 VA)

Residual current (eff.): < 5 mA

### Electronic Inserts EC 22 and EC 23 for DC Voltage (Three-wire connection)

Power supply U =: 10 V...55 V

Superimposed AC voltage U<sub>pp</sub>:  
max. 5 V

Current consumption: max. 15 mA

Load connection: Open Collector;  
PNP (EC 22) or NPN (EC 23)

Switching voltage: max. 55 V

Connected load, short-term  
(max. 1 s): max. 1 A

Connected load, continuous:  
max. 350 mA

Protected against reverse polarity

### Electronic Insert EC 24 for DC and AC Voltages (Relay Output)

Power supply U =: 20 V...200 V  
or power supply U<sub>~</sub>:  
21 V...250 V, 50/60 Hz

Current consumption (eff.): max. 5 mA

Peak inrush current:  
max. 200 mA, max. 5 ms

Pulse current: max. 50 mA, max. 5 ms

Pulse frequency: approx. 1.5 s

Output:  
potential-free change-over contact

Contact load capacity:  
U<sub>~</sub> max. 250 V, I<sub>~</sub> max. 6 A,  
P<sub>~</sub> max. 1500 VA (cos φ = 1) or  
P<sub>~</sub> max. 750 VA, cos φ ≥ 0.7  
U = max. 250 V, I = max. 6 A,  
P = max. 200 W

Operating life: min. 10<sup>5</sup> switchings  
at max. contact load

Additional switching delay:  
max. 1.5 s

Subject to modification

# Order Specification Key Nivocompact FTC 131

**FTC 131 capacitance level limit switch with rod probe,  $\varnothing$  25 mm**

	<b>Weight</b>
<b>Process Connection</b>	
G Thread G 1 1/2", steel	0.48 kg
H Thread NPT 1 1/2", steel	0.48 kg
K Thread G 1 1/2", 1.4571	0.48 kg
N Thread NPT 1 1/2", 1.4571	0.48 kg
Y Others on request	
<b>Probe</b>	
3 350 mm probe length	0.78 kg
9 Others on request	
<b>Housing</b>	
B Aluminium housing, IP 66	0.42 kg
K PBTP synthetic housing, IP 66	0.31 kg
Y Others on request	
<b>Electronic Insert (mounted in housing)</b>	
1 21 V...250 V, 50/60 Hz (EC 20) Two-wire AC connection	0.17 kg
2 PNP 10 V...55 V= (EC 22) Three-wire DC connection	0.17 kg
4 Relay, 21...250 V AC/200 V= (EC 24) AC or DC connection with relay output (change-over contact)	0.17 kg
9 Others on request	

**Order code**

FTC 131				
---------	--	--	--	--

Please state other probe lengths in mm

--	--	--	--

**Total weight**  **kg**

The Nivocompact FTC 131 is designed using these basic modules.

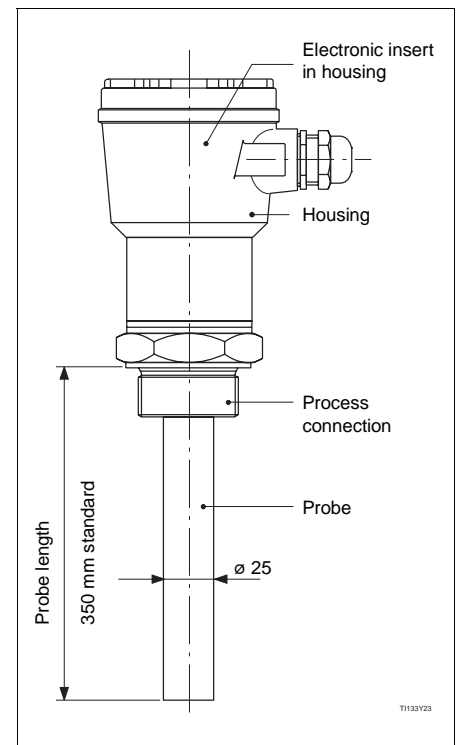

# Order Specification Key Nivocompact FTC 231

FTC 231 capacitance level limit switch with rope probe, $\varnothing$ 10 mm		Weight
<b>Process Connection</b>		
G	Thread G 1 1/2", steel	0.58 kg
H	Thread NPT 1 1/2", steel	0.58 kg
K	Thread G 1 1/2", 1.4571	0.58 kg
N	Thread NPT 1 1/2", 1.4571	0.58 kg
Y	Others on request	
<b>Weight</b>		
1	Cast iron	2.00 kg
9	Others on request	
<b>Probe</b>		
1	...mm probe length Probe lengths from 500 to 22000 mm available	0.29 kg/m
2	2.500 mm (basic length, can be shortened)	0.73 kg
6	6.000 mm (basic length, can be shortened)	1.74 kg
9	Others on request	
<b>Housing</b>		
B	Aluminium housing, IP 66	0.42 kg
K	PBTP synthetic housing, IP 66	0.31 kg
Y	Others on request	
<b>Electronic Insert (mounted in housing)</b>		
1	21 V...250 V, 50/60 Hz (EC 20) Two-wire AC connection	0.17 kg
2	PNP 10 V...55 V= (EC 22) Three-wire DC connection	0.17 kg
4	Relay, 21...250 V AC/200 V= (EC 24) AC or DC connection with relay output (change-over contact)	0.17 kg
9	Others on request	
FTC 231	<input type="text"/> <input type="text"/> <input type="text"/> <input type="text"/> <input type="text"/> <input type="text"/> <input type="text"/> <input type="text"/> <input type="text"/> <input type="text"/> <input type="text"/>	<b>Order code</b>
<input type="text"/> <input type="text"/> <input type="text"/> <input type="text"/>	<b>Total weight</b> <input type="text"/> kg	
<input type="text"/> <input type="text"/> <input type="text"/> <input type="text"/>	Please state length in mm	

The Nivocompact FTC 231 is designed using these basic modules.

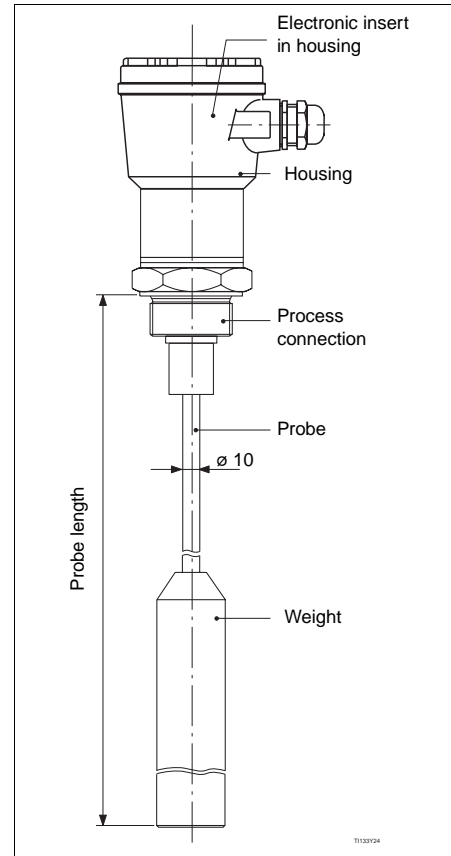

# Order Specification Key Nivocompact FTC 331

**FTC 331 capacitance level limit switch with rope probe,  $\varnothing$  16 mm**

<b>Process Connection</b>		Weight
G Thread G 1 1/2", steel		0.58 kg
H Thread NPT 1 1/2", steel		0.58 kg
K Thread G 1 1/2", 1.4571		0.58 kg
N Thread NPT 1 1/2", 1.4571		0.58 kg
Y Others on request		
<b>Weight</b>		
1 Cast iron		1.88 kg
9 Others on request		
<b>Probe</b>		
1 ...mm probe length Lengths from 500 to 22000 mm available		0.70 kg/m
8 8.000 mm (basic length, can be shortened)		5.60 kg
9 Others on request		
<b>Housing</b>		
B Aluminium housing, IP 66		0.42 kg
K PBTP synthetic housing, IP 66		0.31 kg
Y Others on request		
<b>Electronic Insert (mounted in housing)</b>		
1 21 V...250 V, 50/60 Hz (EC 20) Two-wire AC connection		0.17 kg
2 PNP 10 V...55 V= (EC 22) Three-wire DC connection		0.17 kg
4 Relay, 21...250 V AC/200 V= (EC 24) AC or DC connection with relay output (change-over contact)		0.17 kg
9 Others on request		

FTC 331									
---------	--	--	--	--	--	--	--	--	--

**Order code**

**Total weight**  **kg**

--	--	--	--

Please state length in mm

The Nivocompact FTC 331 is designed using these basic modules.

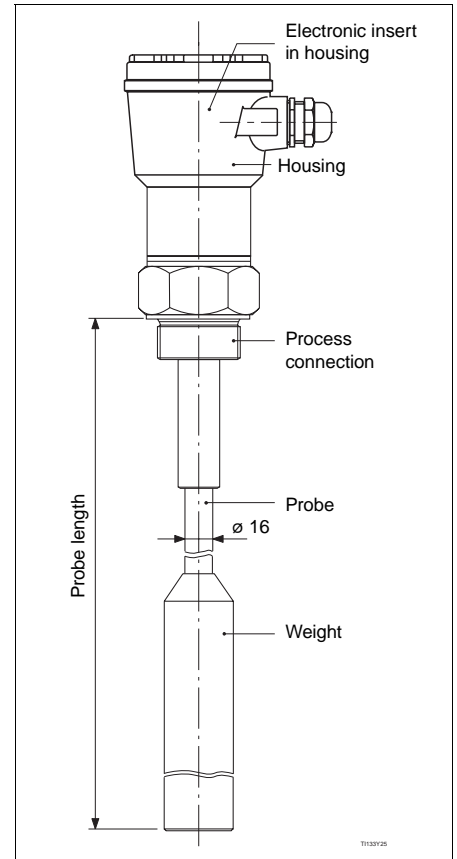

## Accessories

- Seal for thread G1 1/2 A:  
in elastomer/fibre (asbestos-free)  
supplied
- Butterfly Weight  
for FTC 231 or FTC 331  
Material: steel  
Weight: approx. 3.2 kg
- Protective sun cover  
for aluminium housing  
Material: polyamide

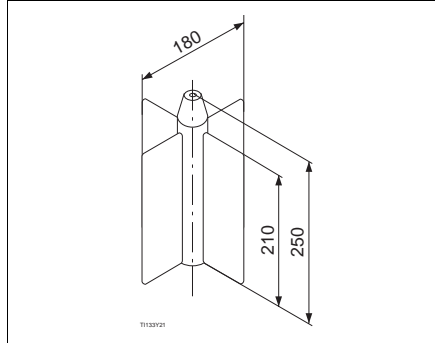

Dimensions of butterfly weight (accessory). This weight provides a larger capacitance difference for rope probes.

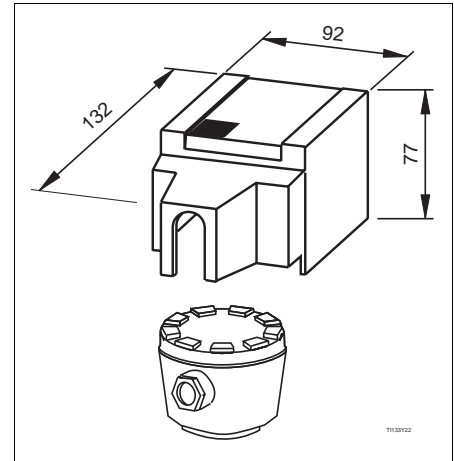

Dimensions of protective sun cover (accessory). This cover prevents condensation in the housing.

## Supplementary Documentation

- Nivocompact FTC 431 with disk probe; for applications where the probe must not project into the silo. Technical Information TI 136F/00/e
- Nivocompact FTC 731 or Nivocompact FTC 831 for applications where high material build-up is expected. Technical Information TI 134F/00/e

## Details When Ordering

- Order Code
- Probe length for FTC 231, FTC 331
- or special version
- Accessories (e.g. protective sun cover)

Endress+Hauser  
GmbH+Co.  
Instruments International  
P.O. Box 2222  
D-79574 Weil am Rhein  
Germany  
Tel. (07621) 975-02  
Tx 773 926  
Fax (07621) 975-345  
<http://www.endress.com>  
[info@ii.endress.com](mailto:info@ii.endress.com)

Endress+Hauser  
The Power of Know How

