

Hazardous location

Class I, Div. 1, 2, Groups A, B, C, D
 Class I, Zone 0, IIC
 AEx ia IIC T6
 Class II, Div. 1, 2, Groups E, F, G
 Class III

Non hazardous location

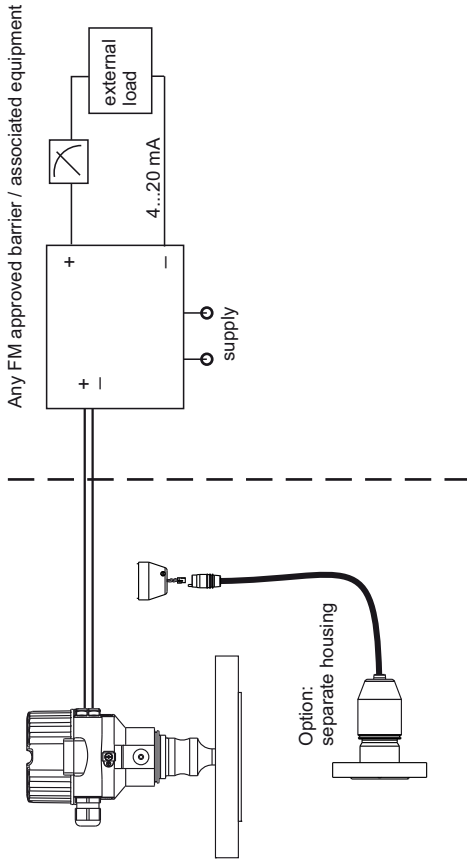

Entity parameter:

$V_{max} = 30$ VDC
 $I_{max} = 300$ mA
 $P_{max} = 1$ W
 $C_i \leq 10$ nF
 $L_i = 0$

Areas of application

The compact instruments are suitable for use in areas subject to explosion caused by gases, vapours or mists.

Table: Permissible ambient temperature and temperature code:

Temperature code	Permissible ambient temperature, electronic compartment
T6	-40...+40°C
T4	-40...+70°C

option for T_a , min: -50°C

The devices are FM Certified as Single Seal per ANSI/ISA 12.27.01 as tabulated below; therefore installation of external secondary seals is not required.

Single Seal	Model	Limited to:	
		MWP*	Process Temperature**
	PMP51, PMP55	400 bar (5800 psi)	-40°C...+100°C
	PMC51	40 bar (600 psi)	-40°C...+125°C

* Limitations of the Maximum Working Pressure (MWP) are marked on the nameplate and must be considered!

** Limitations of the process temperature range depending on the used version are specified in the applicable technical information of the manufacturer and must be considered!
 PMP55 allows higher process temperatures depending on the used diaphragm seal.
 This is allowable provided the above specified process temperatures are guaranteed at the sensor close to the enclosure (location of primary seal) for these types.

Intrinsically safe installation

Intrinsically safe (entity). Class I, II, III, Div. 1, Groups A, B, C, D, E, F, G
 Hazardous Location Installation

- Control room equipment may not use or generate over 250 V.
- Use Factory Mutual Entity-approved intrinsic safety barrier with V_{oc} or $V_t \leq V_{max}$, I_{sc} or $I_t \leq I_{max}$, $C_a \geq C_i + C_{cable}$, $L_a \geq L_i + L_{cable}$.
 Barrier must be incapable of delivering more than 1 Watt to a matched load.
 Transmitter entity parameters are as follows: $V_{max} = 30$ VDC
 $I_{max} = 300$ mA
 $C_i \leq 10$ nF
 $L_i = 0$
 for T-code see table
- Installation should be in accordance with ANSI/ISA RP 12.06.01 "Installation of intrinsically safe systems for hazardous (classified) locations" and the National Electrical Code (ANSI/NFPA 70).
- Warning: Substitution of Components may impair intrinsic safety.
- Intrinsic safety barrier manufacturer's installation drawing must be followed, when installing this equipment: The configuration of the intrinsic safety barrier(s) must be FMRC approved.
- Use supply wires suitable for 5°C above surrounding ambient.
- Avoid electrostatic charging of plastic surfaces, plastic process connections or coatings.

Division 2 and Zone 2 installation

Nonincendive Class I, Div. 2, Groups A, B, C, D.
 Hazardous Location Installation (not for separated housing)

- Installation shall be in accordance with NEC using threaded conduits or other wiring methods in accordance with articles 500 to 510.
 Intrinsic safety barrier not required.
 Max. supply voltage 45 VDC.
 Max. ambient temperature: 70°C.
- Warning: Explosion Hazard - Do not disconnect equipment unless power has been switched off or the area is known to be non hazardous.
- Warning: Substitution of Components may impair suitability for Class I, Div. 2.
- Nonincendive field wiring installation:
 The Nonincendive Field Wiring Circuit Concept allows interconnection of nonincendive field wiring apparatus with associated nonincendive field wiring apparatus or associated apparatus not specifically examined in combination as a system using any of the wiring methods permitted for unclassified locations, when $V_{max} \geq V_{oc}$ or V_t , $C_a \geq C_i + C_{cable}$, $L_a \geq L_i + L_{cable}$.
 Transmitter parameters are as follows: $V_{max} = 45$ VDC; $C_i \leq 10$ nF; $L_i = 0$;
 $I_{max} =$ see note 11
 Max. ambient temperature: 70°C
- For these current controlled circuit, the parameter I_{max} is not required and need not to be aligned with parameter I_{sc} and I_t of the associated nonincendive field wiring apparatus or associated apparatus.

Class II, III installation

DIP for Class II, III, Div. 1, Groups E, F, G
 Hazardous Location Installation
 (not for separated housing, not for PMP51 with flushmounted process connections)

- Installation of transmitter wiring according to NEC using threaded conduits or other wiring methods in accordance with articles 500 to 510.
- Use a dust tight seal at the conduit entry.

Functional ratings:

These ratings do not supersede Hazardous Location values.
 $U_{nom} \leq 45$ VDC
 $I_{nom} = 4...20$ mA (max. 25 mA)

Remark: for service purposes the Endress+Hauser Commubox FXA191 or FXA195 may be connected to the display connection of the electronic insert. Follow the safety advices of the Commubox.

