

Safety Instructions

Cerabar M

PMP51, PMP55

4-20 mA HART, PROFIBUS PA, FOUNDATION Fieldbus

Ex d IIC T6 Gb

Ex d IIC T4 Gb

TÜV 13.2013



Document: XA01284P-A

Safety instructions for electrical apparatus for explosion-hazardous areas

Cerabar M

PMP51, PMP55

4-20 mA HART, PROFIBUS PA, FOUNDATION Fieldbus

Associated Documentation

This document is an integral part of the following Operating Instructions:

HART: BA00382P/00

PROFIBUS PA: BA00383P/00

FOUNDATION Fieldbus: BA00384P/00

The Operating Instructions which are supplied and correspond to the device type apply.

Supplementary Documentation

Explosion-protection brochure:

CP00021Z/11

Designation

Explanation of the labelling and type of protection can be found in the explosion protection brochure.

Designation of type of protection

Ex d IIC T6 Gb

Ex d IIC T4 Gb

Applied standards

ABNT NBR IEC 60079-0 :2008

ABNT NBR IEC 60079-1 :2009

**Safety instructions:
General**

- Comply with the installation and safety instructions in the Operating Instructions.
- Install the device according to the manufacturer's instructions and any other valid standards and regulations.
- Only install the devices in media for which the wetted materials have sufficient durability.
- Avoid electrostatic charging:
 - Of plastic surfaces (e.g. housing, sensor element, special varnishing , attached additional plates, ..)
 - Of isolated capacities (e.g. isolated metallic plates)

**Safety instructions:
Installation**

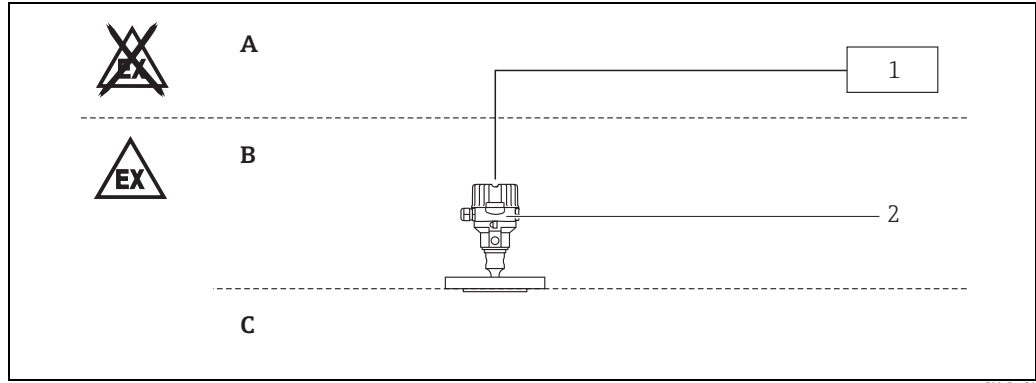

- A Power supply
- B Zone 1, Electronic
- C Zone 1, Process
- 1 Power supply U
- 2 PMP51 or PMP55

- Do not open the connection or electronics compartments under voltage in an explosive atmosphere.
- During operation, the cover must be screwed all the way in and the cover's safety catch must be fastened.
- The plastic sealing plug is used only as transport protection.
- Connect the device using suitable cable and wire entries or using piping systems of protection type "Pressure-tight Enclosure d".
- For connection through a conduit entry approved for this purpose the associated sealing facility shall be mounted directly to the housing.
- For ambient temperatures higher than +70 °C, use suitable heat-resisting cables or wires.
- Close unused entry glands with approved (Ex d) sealing plugs. (Sealing plugs included in delivery).
- Avoid electrostatic charging of the plastic surfaces, for plastic process connections or plastic coatings.
- Avoid impact or friction sparks for light metal flanges or flange faces (e.g. titanium, zirconium).

Temperature tables

Electronic insert	Type of protection	Temperature class	Process temperature	Ambient temperature (Housing)
4-20 mA HART	Ex d IIC T6 or T4 Gb	T6	≤ 80 °C	-40 °C ≤ Ta ≤ +75 °C
		T4	≤ 120 °C	
PROFIBUS PA, FOUNDATION Fieldbus	Ex d IIC T6 or T4 Gb	T6	≤ 80 °C	-40 °C ≤ Ta ≤ +75 °C
		T4	≤ 120 °C	

The process temperatures refer to the temperature at the separation membrane of PMP51. For PMP55, higher temperatures are permitted depending on the type of diaphragm seal (do not exceed the max. ambient temperature at the housing).

Connection data

Electronic insert	Electrical data
4-20 mA HART	U ≤ 45 V DC P ≤ 1.1 W
PROFIBUS PA, FOUNDATION Fieldbus	U ≤ 32 V DC P ≤ 1.25 W



71250776

www.addresses.endress.com
