

Operating Instructions

Rxn-10 Raman spectroscopic probe



Table of Contents

1 About this document.....	4	5 Probe and fiber optic connection	11
1.1 Warnings.....	4	5.1 FC cable assembly	11
1.2 Symbols on the device.....	4	5.2 EO fiber cable	12
1.3 U.S. export compliance	4	5.3 Changing optics.....	13
1.4 Glossary	5	6 Installation	16
2 Basic safety instruction	6	7 Commissioning.....	17
2.1 Requirements for the personnel.....	6	7.1 Receipt of probe	17
2.2 Designated use	6	7.2 Probe calibration and verification.....	17
2.3 Workplace safety.....	6	8 Operation	18
2.4 Operational safety.....	6	9 Diagnostics and troubleshooting	19
2.5 Laser safety	7	10 Maintenance.....	20
2.6 Service safety	7	10.1 Inspecting and cleaning the optical fibers	20
2.7 Important safeguards	7	11 Repair	21
2.8 Product safety.....	7	12 Technical data	22
3 Product description	9	12.1 Specifications.....	22
3.1 The Rxn-10 probe	9	12.2 Maximum permissible exposure	23
3.2 Rxn-10 probe and accessory optics	9	13 Supplementary documentation	25
4 Incoming product acceptance and product identification	10	14 Index.....	26
4.1 Incoming acceptance.....	10		
4.2 Product identification	10		
4.3 Scope of delivery.....	10		

1 About this document

1.1 Warnings



Structure of Information	Meaning
 WARNING Causes (/consequences) If necessary, consequences of non-compliance (if applicable) ▶ Corrective action	This symbol alerts you to a dangerous situation. Failure to avoid the dangerous situation can result in a fatal or serious injury.
 CAUTION Causes (/consequences) If necessary, consequences of non-compliance (if applicable) ▶ Corrective action	This symbol alerts you to a dangerous situation. Failure to avoid this situation can result in minor or more serious injuries.
 NOTICE Cause/situation If necessary, consequences of non-compliance (if applicable) ▶ Action/note	This symbol alerts you to situations which may result in damage to property.

Table 1. Warnings

1.2 Symbols on the device





Symbol	Description
	The Laser Radiation symbol is used to alert the user to the danger of exposure to hazardous visible laser radiation when using the Raman Rxn system.
	The High Voltage symbol that alerts people to the presence of electric potential large enough to cause injury or damage. In certain industries, high voltage refers to voltage above a certain threshold. Equipment and conductors that carry high voltage warrant special safety requirements and procedures.
	The WEEE symbol indicates that the product should not be discarded as unsorted waste but must be sent to separate collection facilities for recovery and recycling.
	The CE Marking indicates conformity with health, safety, and environmental protection standards for products sold within the European Economic Area (EEA).

Table 2. Symbols

1.3 U.S. export compliance

The policy of Endress+Hauser is strict compliance with U.S. export control laws as detailed in the website of the [Bureau of Industry and Security](#) at the U.S. Department of Commerce.

1.4 Glossary

Term	Description
ANSI	American National Standards Institute
°C	Celsius
CDRH	Center for Devices and Radiological Health
CFR	Code of Federal Regulations
cm	centimeter
CSA	Canadian Standards Association
EO	electro-optical
°F	Fahrenheit
FC	fiber channel
ft.	feet
HCA	Raman Calibration Accessory
IEC	International Electrotechnical Commission
in.	inches
kg	kilogram
lb.	pound
LED	light emitting diode
m	meter
µm	micrometer
mm	millimeter
MPE	maximum permissible exposure
mW	milliwatt
nm	nanometer
psi	pounds per square inch
RD	red
WEEE	Waste Electrical and Electronic Equipment
YE	yellow

Table 3. Glossary

2 Basic safety instruction

2.1 Requirements for the personnel

- Installation, commissioning, operation, and maintenance of the measuring system may be carried out only by specially trained technical personnel.
- The technical personnel must be authorized by the plant operator to carry out the specified activities.
- The technical personnel must have read and understood these Operating Instructions and must follow the instructions contained herein.
- The facility must designate a laser safety officer who ensures staff are trained on all Class 3B laser operating and safety procedures.
- Faults at the measuring point may only be rectified by properly authorized and trained personnel. Repairs not described in this document must be carried out only directly at the manufacturer's site or by the service organization.

2.2 Designated use

The Rxn-10 Raman spectroscopic probe is designed for sample measurements in a laboratory, process development, or manufacturing (when part of a single-use probe system) environment. The probe head is compatible with a wide range of interchangeable, commercially available optics (immersion and non-contact) to meet the requirements of different applications. Recommended applications include:

- **Chemical:** reaction monitoring, blending, catalyst monitoring, hydrocarbon speciation, process unit optimization
- **Polymer:** polymerization reaction monitoring, extrusion monitoring, polymer blending
- **Pharmaceutical:** active pharmaceutical ingredient reaction monitoring, crystallization
- **Biopharmaceutical:** cell culture and fermentation monitoring, optimization, control
- **Food and beverage:** zonal heterogeneity mapping of meats and fish

Use of the device for any purpose other than that described, poses a threat to the safety of people and of the entire measuring system and invalidates any warranty.

2.3 Workplace safety

As the user, you are responsible for complying with the following safety conditions:

- Installation guidelines
- Local standards and regulations for electromagnetic compatibility

The product has been tested for electromagnetic compatibility in accordance with the applicable international standards for industrial applications.

The electromagnetic compatibility indicated applies only to a product that has been properly connected to the analyzer.

2.4 Operational safety

Before commissioning the entire measuring point:

1. Verify that all connections are correct.
2. Ensure that electro-optical cables are undamaged.
3. Ensure fluid level is sufficient for probe/optics immersion (if applicable).
4. Do not operate damaged products, and protect them against unintentional operation.
5. Label damaged products as defective.

During operation:

1. If faults cannot be rectified, products must be taken out of service and protected against unintentional operation.
2. When working with laser devices, always follow all local laser safety protocols which may include the use of personal protective equipment and limiting device access to authorized users.

2.5 Laser safety

The Rxn-10 probe is connected to a Raman Rxn analyzer. Raman Rxn analyzers use Class 3B lasers as defined in the following:

- [American National Standards Institute](#) (ANSI) Z136.1, American National Standard for Safe Use of Lasers
- [International Electrotechnical Commission](#) (IEC) 60825-1, Safety of Laser Products – Part 1

⚠ WARNING

Laser radiation

- ▶ Avoid exposure to beam
- ▶ Class 3B laser product

⚠ CAUTION

Laser beams can cause ignition of certain substances such as volatile organic compounds.

The two possible mechanisms for ignition are direct heating of the sample to a point causing ignition and the heating of a contaminant (such as dusts) to a critical point leading to ignition of the sample.

The laser configuration presents further safety concerns because the radiation is nearly invisible. Always be aware of the initial direction and possible scattering paths of the laser. The use of laser glasses with OD3 or greater is highly recommended for 532 nm and 785 nm excitation wavelengths and OD4 or greater for a 993 nm excitation wavelength.

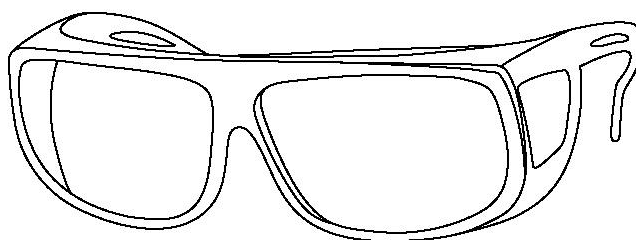

A0048421

Figure 1. Laser safety glasses

For more assistance with taking appropriate precautions and setting the proper controls when dealing with lasers and their hazards, refer to the most current version of ANSI Z136.1 or IEC 60825-14. See Section 12 →  of this document for relevant parameters to enable calculation of maximum permissible exposure (MPE).

2.6 Service safety

Follow your company's safety instructions when removing a process probe from the process interface for service. Always wear proper protective equipment when servicing the equipment.

2.7 Important safeguards

- Do not use the Rxn-10 probe for anything other than its intended use.
- Do not look directly into the laser beam.
- Do not point the laser at a mirrored/shiny surface or a surface that may cause diffuse reflections. The reflected beam is as harmful as the direct beam.
- Do not leave attached and unused probes uncapped or unblocked.
- Always use a laser beam block to avoid inadvertent scatter of laser radiation.

2.8 Product safety

This product is designed to meet all current safety requirements, has been tested, and shipped from the factory in a safe operating condition. The relevant regulations and international standards have been observed. Devices connected to an analyzer must also comply with the applicable analyzer safety standards.

Endress+Hauser Raman spectroscopy systems incorporate the following safety features to conform to the United States Government requirements 21 [Code of Federal Regulations](#) (CFR) Chapter 1, Subchapter J as administered by the [Center for Devices and Radiological Health](#) (CDRH) and IEC 60825-1 as administered by the [International Electrotechnical Commission](#).

2.8.1 CDRH and IEC compliance

Endress+Hauser Raman analyzers are certified by Endress+Hauser to meet CDRH requirements, as well as IEC 60825-1 safety standards for international use.

Endress+Hauser Raman analyzers have been registered with the CDRH. Any unauthorized modifications to an existing Raman Rxn analyzer or accessory may result in hazardous radiation exposure. Such modifications may result in the system being no longer in conformance with federal requirements as certified by Endress+Hauser.

2.8.2 Laser safety interlock

The Rxn-10 probe, as installed, forms part of the interlock circuit. If the fiber cable is severed, the laser will turn off within milliseconds of the breakage.

NOTICE

Handle probes and cables with care.

Fiber cables should NOT be kinked and should be routed to maintain the minimum bend radius of 152.4 mm (6 in.).

- ▶ Permanent damage may result if cables are not routed appropriately.

2.8.3 Laser radiation emission indicator and laser beam shutter

In addition to the CDRH-compliant indicators on the base unit of a Raman Rxn analyzer, the Rxn-10 probe has an electrically powered CRDH-compliant laser emission indicator.

The Rxn-10 probe incorporates a laser beam shutter that can be closed to prevent laser emission. Position “I” indicates emission potential. Moving the lever passed position “O” indicates emission is shuttered.

WARNING

The shutter lever must be moved beyond the “O” to the detent to completely shutter the emission.

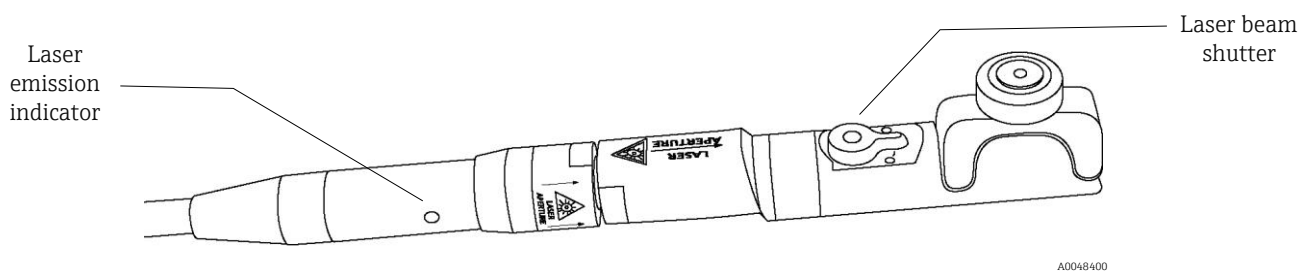

Figure 2. Location of the laser emission indicator and laser beam shutter

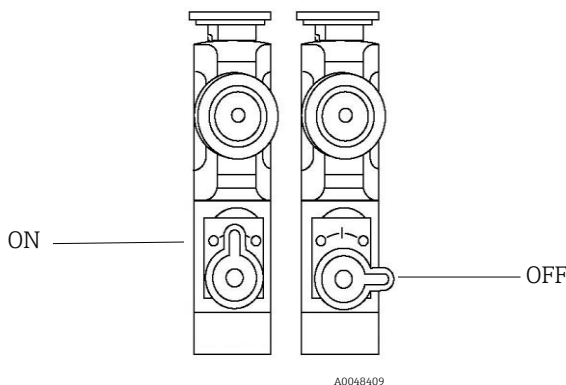

Figure 3. ON and OFF positions of the laser beam shutter

3 Product description

3.1 The Rxn-10 probe

The Rxn-10 Raman spectroscopic probe, powered by Kaiser Raman technology, offers multi-purpose convenience for both solids and liquids analysis in the laboratory environment. It is designed to be compatible with Endress+Hauser Raman Rxn analyzers operating at 532 nm, 785 nm, or 993 nm. Each Rxn-10 probe is designed specifically for a single laser excitation wavelength.

The fiber cable is not removable from the body of the Rxn-10 probe.

3.2 Rxn-10 probe and accessory optics

The probe head is compatible with the following accessory optics to meet the requirements of different applications. Refer to the *Accessory optics for the Rxn-10 probe Operating Instructions* for additional details.

	Optics	Applications
Non-contact optics	 <p style="text-align: center;">A0048410 A0048676</p>	For use with solids or turbid media; also well-suited for delicate or corrosive liquids when sample contamination or damage to optical components is a concern.
Immersion optics (IO)	 <p style="text-align: right;">A0048411</p>	For use in reaction vessels, laboratory reactors, or process streams.
bIO-Optic	 <p style="text-align: right;">A0048412</p>	For use with continuous inline measurement in benchtop bioreactor/fermenter applications requiring headplate entry.
Raman optic system for single use	 <p style="text-align: right;">A0048413</p>	For use with disposable fittings for single-use applications.

Table 4. Optics and applications

4 Incoming product acceptance and product identification

4.1 Incoming acceptance

1. Verify that the packaging is undamaged. Notify the supplier of any damage to the packaging. Keep the damaged packaging until the issue has been resolved.
2. Verify that the contents are undamaged. Notify the supplier of any damage to the delivery contents. Keep the damaged goods until the issue has been resolved.
3. Check that the delivery is complete and nothing is missing. Compare the shipping documents with your order.
4. Pack the product for storage and transportation in such a way that it is protected against impact and moisture. The original packaging offers the best protection. Make sure to comply with the permitted ambient conditions.

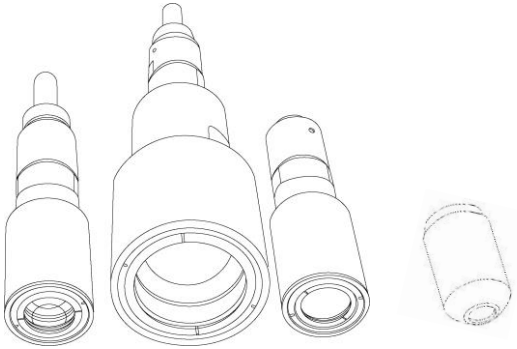
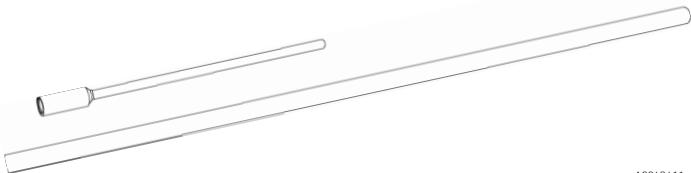
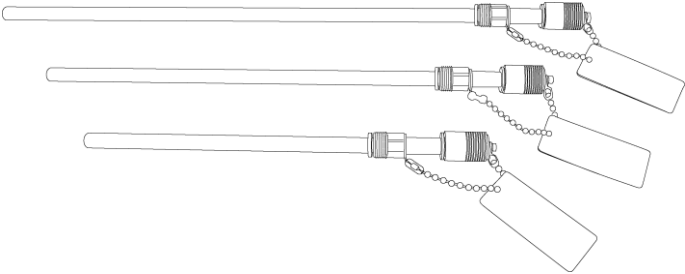
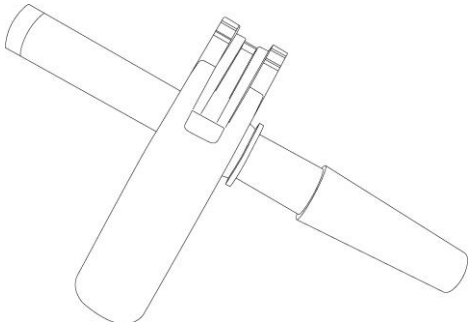
If you have any questions, please contact your supplier or your local sales center.

NOTICE

Probe may be damaged during transport if packaged inadequately.

4.2 Product identification

4.2.1 Label

At a minimum, the probe/tag is labeled with the following information:

- Endress+Hauser branding
- Serial number

Where size allows, the following information is also included:

- Product identification (e.g., Rxn-10)
- Extended order code
- Manufacturer information
- Key functional aspects of the probe (e.g., material, wavelength, focal depth)
- Safety warnings and certification information, as applicable

Compare the information on the label/tag with the order.

4.2.2 Manufacturer address

Endress+Hauser
371 Parkland Plaza
Ann Arbor, MI 48103 USA

4.3 Scope of delivery

The scope of delivery comprises:

- Rxn-10 probe
- *Rxn-10 Raman spectroscopic probe Operating Instructions* manual
- Certificate of Product Performance
- Local declarations of conformity, if applicable
- Rxn-10 probe optional accessories, if applicable
- Material certificates, if applicable

If you have any queries, please contact your supplier or local sales center.

5 Probe and fiber optic connection

The Rxn-10 probe is compatible with the complete line of Endress+Hauser Raman Rxn analyzers.

The Rxn-10 probe connects to the Raman Rxn analyzer via one of the following:

- Fiber channel (FC) cable assembly for use with Raman Rxn analyzers built before September 2019
- Electro-optical (EO) fiber cable for use with Raman Rxn analyzers built during or after September 2019

The fiber cable is not removable from the body of the Rxn-10 probe. Optional extension fiber cables are available.

Refer to the applicable Raman Rxn analyzer operating instructions for analyzer connection details.

NOTICE

Connection of the probe to the FC cable assembly or the EO fiber cable must be conducted by a qualified Endress+Hauser engineer or specially trained technical personnel.

- ▶ Unless trained by qualified personnel, customer attempts to connect the probe to the fiber optic cable can result in damage and may void the warranty.
- ▶ Contact your local Endress+Hauser service representative for additional support regarding the probe and fiber cable connection.

5.1 FC cable assembly

The FC cable assembly connects the Rxn-10 probe to the analyzer via the following:

- Electrical interlock connector
- Yellow (YE) excitation fiber for laser output
- Red (RD) collection fiber for spectrograph input

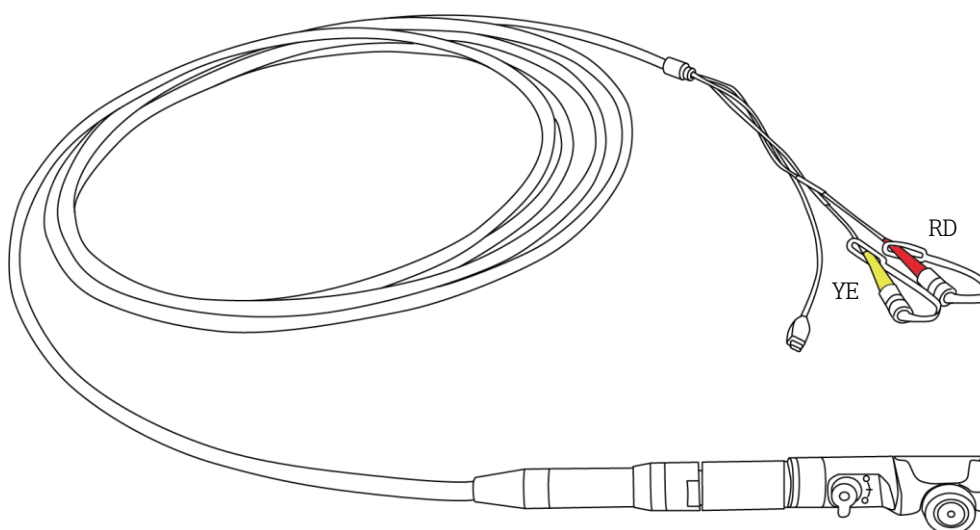

A0048414

Figure 4. Rxn-10 probe with FC cable assembly

5.2 EO fiber cable

The EO fiber cable connects the Rxn-10 probe to the analyzer with a single, robust connector that contains the excitation and collection fiber-optics as well as an electrical laser interlock.

An EO extension cable is available for longer cable runs or installation in conduit.

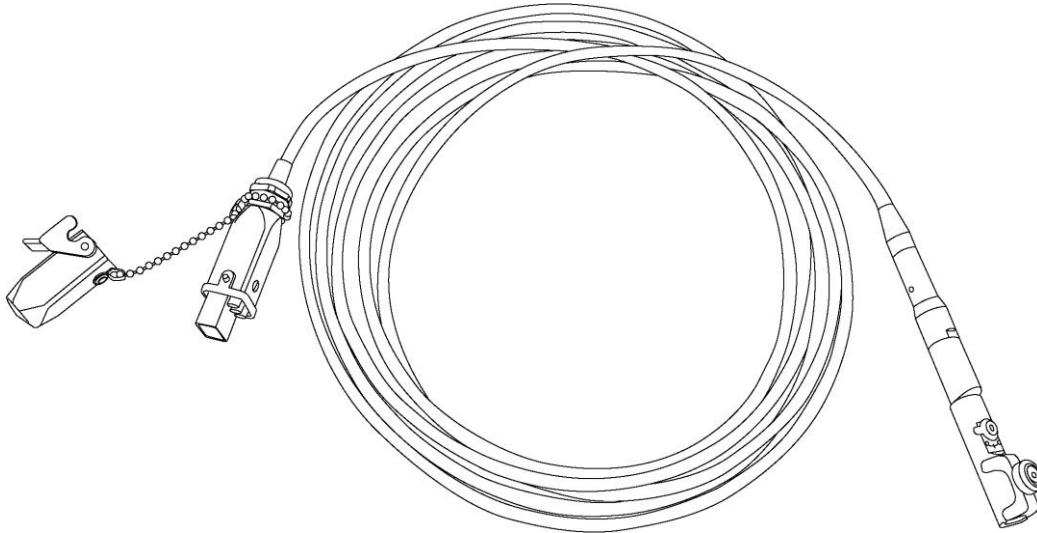

A0048415

Figure 5. Rxn-10 probe with EO fiber cable

5.3 Changing optics

The Rxn-10 probe is compatible with a variety of immersion optics and non-contact optics. The probe head has a compression clamp that secures the immersion optics. The clamp also holds the adapter for non-contact optics.

When replacing an optic on a probe head, use the Raman Calibration Accessory (or HCA) to perform an intensity calibration for that probe head with the new optic.

5.3.1 Changing immersion optics and bIO-Optics

Endress+Hauser immersion optics and bIO-Optics are not threaded. They slip into the Rxn-10 probe and are secured by a thumb screw-based clamp.

⚠ WARNING

When installing or removing immersion optics, ensure the laser and emission shutter are in the closed position.

To install an immersion optic:

1. Loosen the torque limiting thumb screw on the Rxn-10 probe by turning the screw approximately one turn (do not remove). Then find the probe end of the optic, which is the end that includes the product markings.
2. Insert the probe end of the optic through the end optic clamp.
3. Push the optic back until it stops.
4. Tighten the thumb screw to hold the optic in place. Failure to tighten the screw will result in the optic coming loose, potentially damaging the optic.
5. After installing an optic on a probe head, use the Raman Calibration Accessory to perform an intensity calibration for the probe head with the new optic before use.

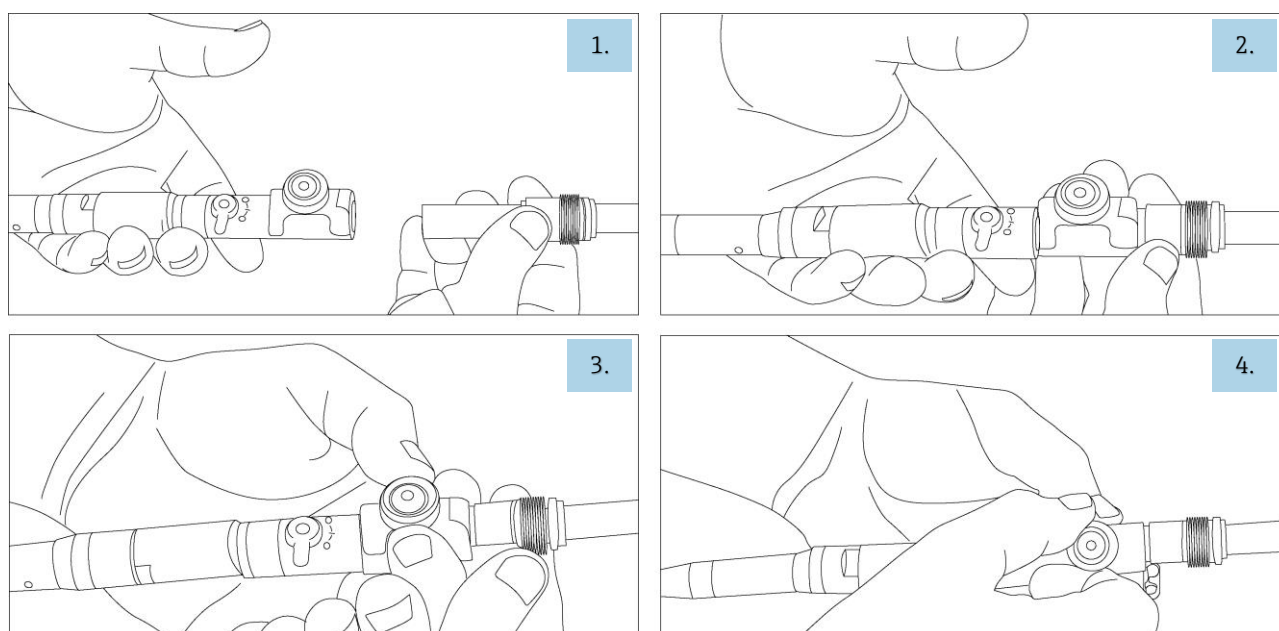

A0048416

Figure 6. Installing an immersion optic (IO) or bIO-Optic on an Rxn-10 probe

To remove an immersion optic:

1. Loosen the torque limiting thumb screw by turning it approximately one turn so that the immersion optic is released from its clamp. Do not remove the screw.
2. Slide the immersion optic out.

5.3.2 Changing the Raman optic system for single use

The Endress+Hauser Raman optic system for single use is not threaded. It slips into the Rxn-10 probe and is secured by a thumb screw-based clamp.

⚠ WARNING

When installing or removing optics, ensure the laser and emission shutter are in the closed position.

To install the Raman optic system for single use:

1. Loosen the torque limiting thumb screw on the Rxn-10 probe by turning the screw approximately one turn (do not remove). Then insert the optic through the end optic clamp.
2. Push the optic back until it stops.
3. Tighten the torque limiting thumb screw to hold the optic in place. Failure to tighten the screw will result in the optic coming loose, potentially damaging the optic.
4. After installing an optic on a probe head, use the Raman Calibration Accessory to perform an intensity calibration for the probe head with the new optic and single use calibration adapter.

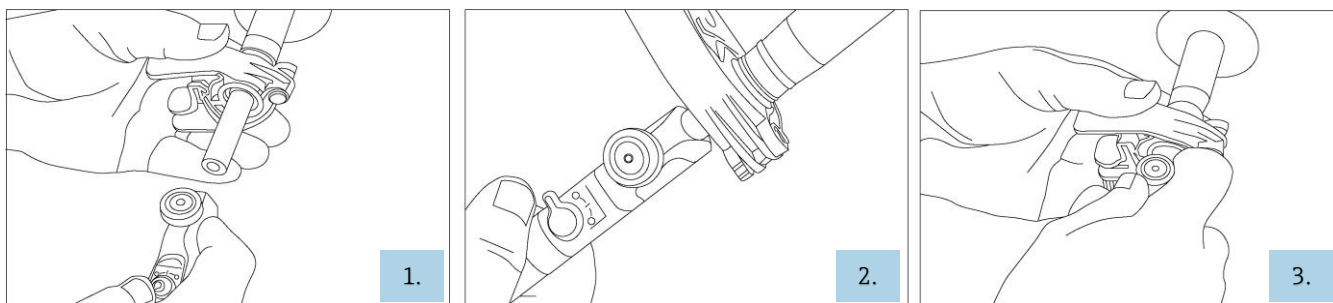

A0048417

Figure 7. Installing the Raman optic system for single use on an Rxn-10 probe

To remove the Raman optic system for single use:

1. Loosen the torque limiting thumb screw by turning it approximately one turn so that the optic is released from its clamp. Do not remove the screw.
2. Slide the optic out.

5.3.3 Changing non-contact optics

The non-contact optics offered with the Rxn-10 probe are threaded, so a threaded adapter is required to attach the optic to the Rxn-10 probe.

⚠ WARNING

When installing or removing non-contact optics, ensure the laser and emission shutter are in the closed position.

To install a non-contact optic:

1. Loosen the torque limiting thumb screw on the Rxn-10 probe by turning the screw approximately one turn (do not remove). Then find the narrow, non-threaded end of the adapter.
2. Insert the narrow end of the adapter through the clamp. Push the adapter back until it stops.
3. Tighten the torque limiting thumb screw to hold the adapter in place.
4. Find the male threaded end of the non-contact optic.
5. Screw a non-contact optic onto the threaded end of the adapter.
6. After installing an optic on a probe head, use the Raman Calibration Accessory to perform an intensity calibration for the probe head with the new optic before use.

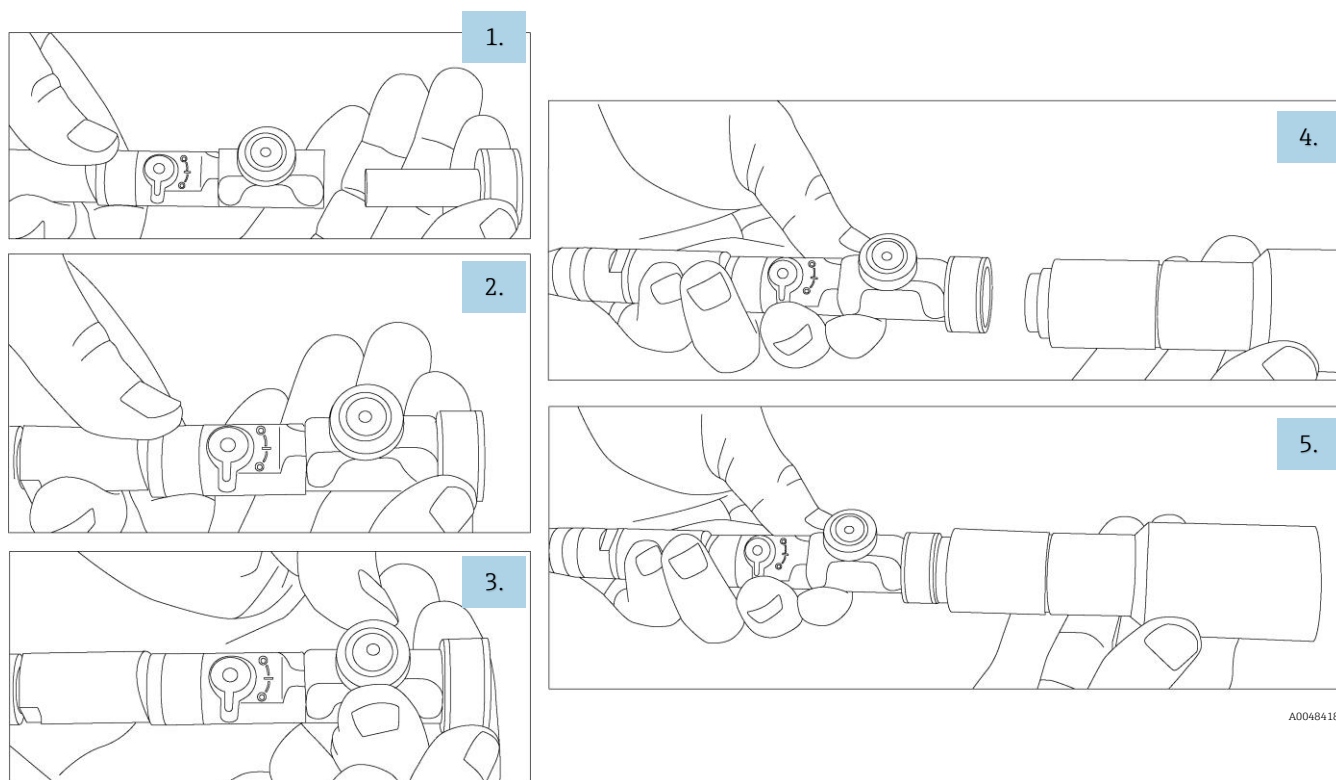

Figure 8. Installing an adapter and non-contact optic on an Rxn-10 probe

To remove a non-contact optic:

1. Unscrew the non-contact optic from the adapter.
2. If an immersion optic will be used, remove the adapter by turning the torque limiting thumb screw approximately one turn until the adapter is released from the clamp. Slide the adapter out.

6 Installation

During installation, standard eye and skin safety precautions for Class 3B laser products (as per EN 60825/IEC 60825-14) should be observed. Additionally, observe the following:

⚠ WARNING	Standard precautions for laser products should be observed. <ul style="list-style-type: none">▶ Probes should always be capped or pointed away from people toward a diffuse target if not installed in a sample chamber.
⚠ CAUTION	The laser input into the Rxn-10 probe must not exceed 499 mW. If stray light is allowed to enter an unused probe, it will interfere with data collected from a used probe and may cause calibration failure or measurement errors. <ul style="list-style-type: none">▶ Unused probes should ALWAYS be capped to prevent stray light from entering the probe.
NOTICE	When installing the probe <i>in situ</i>, the user must provide the strain relief to the fiber optic cable at the probe installation location.

7 Commissioning

The Rxn-10 probe is delivered ready to connect to the Raman Rxn analyzer. No additional alignment or adjustment to the probe is required. Follow the instructions below to commission the probe for use.

7.1 Receipt of probe

Perform the steps for incoming product acceptance described in Section 4.1 → .

7.2 Probe calibration and verification

The probe and the analyzer must be calibrated before use.

After installing an optic on the probe head, use the Raman Calibration Accessory (HCA) to perform an intensity calibration for the probe head with the new optic.

Refer to the applicable Raman Rxn analyzer operating instructions for steps to:

- Perform internal analyzer calibration; may include alignment calibration, full wavelength calibration or full laser wavelength calibration depending on status of analyzer
- Perform probe calibration; requires HCA with an appropriate optic adapter
- Perform probe verification; verifies the calibration results using a standard reference sample
- View calibration and verification reports

The Raman RunTime software will not allow spectra to be collected without passing internal and probe calibrations. Passing the probe verification step is not required but highly recommended.

Raman Rxn analyzer operating instructions are available by searching the Downloads area of the Endress+Hauser web site: <https://endress.com/downloads>

8 Operation

The Endress+Hauser Rxn-10 probe is a versatile probe designed for product and process development. The probe variants are designed to be compatible with Endress+Hauser Raman Rxn analyzers operating at 532 nm, 785 nm, or 993 nm. The Rxn-10 probe accepts a variety of interchangeable optics.

Refer to the applicable Raman Rxn analyzer operating instructions and optics operating instructions for additional instructions for use.

9 Diagnostics and troubleshooting

Refer to the table below when troubleshooting issues with the Rxn-10 probe. When an attached probe is not in use, ensure the laser beam shutter on the probe is in the OFF position (O) and any attached optic is capped to prevent stray light from entering the system.

If the probe is damaged, isolate the probe from the process stream and turn off the laser prior to evaluation. Contact your service representative as needed for assistance.

Symptom		Possible cause	Action
1	Substantial reduction in signal or signal-to-noise ratio	Window fouling of attached optic	<ol style="list-style-type: none"> Carefully remove optic attached to the probe from the sampling environment, decontaminate, and inspect optical window. If necessary, clean the window before returning the optic to service.
		Cracked but intact fiber	Verify condition of fiber and contact your service representative for replacement.
2	Complete loss of signal while laser is powered and laser emission indicator is lit	Broken fiber without interlock wire breakage	Ensure all fiber connections are secure.
		Laser beam shutter is in the closed (O) position	Ensure the laser beam shutter is in the open (I) position.
3	Laser emission indicator on probe is not lit	Damaged fiber assembly	Look for signs of breakage in fiber. Contact your service representative for replacement.
		Fiber cable EO connector not secured/latched	Ensure EO connector is properly connected and latched at the probe (if applicable) and at the analyzer.
		Remote interlock connector disconnected	Ensure the twist-lock remote interlock connector at the rear of analyzer (next to fiber EO connector) is connected for the specific channel.
4	Unstable signal and contamination visible behind optic window	Window seal failure of attached optic	<ol style="list-style-type: none"> Examine the area inside the window of attached optic for moisture or condensation. Examine the attached optic for fluid penetration or signs of sample fluid in the optic body (e.g., corrosion, residue). Look for any sign of spectral deviation. If any of the above are noted, contact your service representative to return the probe to the manufacturer.
5	Decreased laser power or collection efficiency	Contaminated fiber connection	Carefully clean the fiber ends at the probe. Refer to the applicable Raman Rxn analyzer operating instructions for cleaning instructions and steps for starting up a new probe.
6	Laser interlock on analyzer causes laser to shut down	Laser interlock activated	Check for fiber breakage on all connected fiber optic cable channels and ensure remote interlock connectors are in place on each channel.
7	Unrecognized bands or patterns in the spectra	Cracked but intact fiber	Verify possible causes and contact your service representative to return the damaged product.
		Contaminated tip of attached optic	
		Contaminated internal optics of probe	
8	Other unexplained negative performance of the probe	Optic is not seated properly	Reseat the optic and perform a probe calibration. Refer to the applicable Raman Rxn analyzer operating instructions for probe calibration steps.
		Thumb screw is not properly secured to the probe	Tighten the nut in the center of the thumb screw using a hex key.
		Physical damage to probe head or optics	Contact your service representative to return the damaged product.

Table 5. Troubleshooting

10 Maintenance

10.1 Inspecting and cleaning the optical fibers

The optical fiber connectors (FC or EO) must be clean and free of debris and oil to achieve optimal performance. If cleaning is required, refer to the applicable Raman Rxn analyzer or fiber optic cables operating instructions.

11 Repair

Repairs not described in this document must be carried out only directly at the manufacturer's site or by the service organization. For Technical Service, refer to our website (<https://endress.com/contact>) for the list of local sales channels in your area.

If a product must be returned for repair or replacement, follow all decontamination procedures indicated by your service provider.

⚠ WARNING

Failure to properly decontaminate wetted parts before return can result in a fatal or serious injury.

To ensure swift, safe, and professional product returns, please contact your service organization.

For additional product return information, refer to the following site and select the applicable market/region:
<https://www.endress.com/en/instrumentation-services/instrumentation-repair>

12 Technical data

12.1 Specifications

Item		Description
Laser wavelength	With non-contact optic or immersion optic	532 nm, 785 nm, or 993 nm
	With bIO-Optic or Raman optic system for single use	785 nm or 993 nm
Maximum laser power into probe head		< 499 mW
Working distance		Based on the sampling optic selected
Sample interface		Based on the sampling optic selected
Polarization at sample		Unpolarized
Probe temperature		-10 to 70 °C (14 to 158 °F)
Temperature ramp		≤ 30 °C/min (≤ 54 °F/min)
Probe relative humidity		20 to 60 %, non-condensing
Probe spectral coverage		Probe spectral coverage is limited by the coverage of the analyzer being used
Laser power at sample	532 nm (with standard 120-mW laser)	> 45 mW
	785 nm (with standard 400-mW laser)	> 150 mW
	993 nm (with standard 400-mW laser)	> 150 mW
Materials of construction	Probe body	6061 aluminum, 316L stainless steel, and 303 stainless steel
	Fiber optic cable	Design: PVC jacketed, proprietary construction Connections: proprietary electro-optic or FC to EO fiber converter(s) for non-embedded systems
Probe	Length (not including fiber cable bend radius)	203 mm (8 in.)
	Length (including fiber cable bend radius)	356 mm (14.02 in.)
	Diameter (not including cable)	19 mm (0.75 in.)
	Weight (including cable)	0.5 kg (approximately 1 lb.)
Fiber optic cable	Temperature*	-40 to 70 °C (-40 to 158 °F)
	Length	5 to 25 m (16.4 to 82.0 ft.) lengths standard in 5 m (16.4 ft.) increments EO male to EO female extensions are also available in lengths from 5 to 200 m (16.4 to 656.2 ft.) in 5 m (16.4 ft.) increments (limited by application)
	Minimum bend radius	152.4 mm (6 in.)
	Flame resistance	Certified: CSA-C/US AWM I/II, A/B, 80C, 30V, FT1, FT2, VW-1, FT4 Rated: AWM I/II A/B 80C 30V FT4

* While the fiber optic cable can withstand temperatures up to 80 °C (176 °F), the interface of the cable to the probe head is limited to 70 °C (158 °F).

Table 6. Specifications

12.2 Maximum permissible exposure

The maximum permissible exposure (MPE) is the maximum level of laser radiation exposure that can occur before causing ocular or skin damage. The MPE is calculated using the laser wavelength (λ) in nanometers, the duration of the exposure in seconds (t), and the energy involved ($\text{J}\cdot\text{cm}^{-2}$ or $\text{W}\cdot\text{cm}^{-2}$).

A correction factor (C_A) may also be required and can be determined below.

Wavelength λ (nm)	Correction factor C_A
400 to 700	1
700 to 1050	$10^{0.002(\lambda-700)}$
1050 to 1400	5

Table 7. Wavelength dependent correction factor C_A

12.2.1 MPE for ocular exposure

The ANSI Z136.1 standard provides means to perform MPE for ocular exposure. Please refer to the standard to calculate the relevant MPE levels for the case of laser exposure from the Rxn-10 probe and from the unlikely occurrence of laser exposure from a broken optical fiber.

Maximum permissible exposure (MPE) for point source ocular exposure to a laser beam			
Wavelength λ (nm)	Exposure duration t (s)	MPE calculation	
		($\text{J}\cdot\text{cm}^{-2}$)	($\text{W}\cdot\text{cm}^{-2}$)
532	10^{-13} to 10^{-11}	1.0×10^{-7}	-
	10^{-11} to 5×10^{-6}	2.0×10^{-7}	-
	5×10^{-6} to 10	$1.8 t^{0.75} \times 10^{-3}$	-
	10 to 30,000	-	1×10^{-3}

Table 8. MPE for ocular exposure with 532 nm laser emission

Maximum permissible exposure (MPE) for point source ocular exposure to a laser beam				
Wavelength λ (nm)	Exposure duration t (s)	MPE calculation		MPE where $C_A = 1.4791$
		($\text{J}\cdot\text{cm}^{-2}$)	($\text{W}\cdot\text{cm}^{-2}$)	
785 and 993	10^{-13} to 10^{-11}	$1.5 C_A \times 10^{-8}$	-	2.2×10^{-8} ($\text{J}\cdot\text{cm}^{-2}$)
	10^{-11} to 10^{-9}	$2.7 C_A t^{0.75}$	-	Insert time (t) and calculate
	10^{-9} to 18×10^{-6}	$5.0 C_A \times 10^{-7}$	-	7.40×10^{-7} ($\text{J}\cdot\text{cm}^{-2}$)
	18×10^{-6} to 10	$1.8 C_A t^{0.75} \times 10^{-3}$	-	Insert time (t) and calculate
	10 to 3×10^4	-	$C_A \times 10^{-3}$	1.4971×10^{-3} ($\text{W}\cdot\text{cm}^{-2}$)

Table 9. MPE for ocular exposure with 785 nm or 993 nm laser emission

12.2.2 MPE for skin exposure

The ANSI Z136.1 standard provides means to perform MPE for skin exposure. Please refer to the standard to calculate the relevant MPE levels for the case of laser exposure from the Rxn-10 probe and from the unlikely occurrence of laser exposure from a broken optical fiber.

Maximum permissible exposure (MPE) for skin exposure to a laser beam				
Wavelength λ (nm)	Exposure duration t (s)	MPE calculation		MPE where $C_A = 1.4791$
		(J·cm ⁻²)	(W·cm ⁻²)	
532, 785 and 993	10 ⁻⁹ to 10 ⁻⁷	2 $C_A \times 10^{-2}$	-	2.9582 × 10 ⁻² (J·cm ⁻²)
	10 ⁻⁷ to 10	1.1 $C_A t^{0.25}$	-	Insert time (t) and calculate
	10 to 3 × 10 ⁴	-	0.2 C_A	2.9582 × 10 ⁻¹ (W·cm ⁻²)

Table 10. MPE for skin exposure with 532 nm, 785 nm or 993 nm laser emission

13 Supplementary documentation

All documentation is available:

- On the Endress+Hauser Operations App for smartphone/tablet
- In the Downloads area of the Endress+Hauser website: <https://endress.com/downloads>

Part number	Document type	Document title
KA01546C	Brief Operating Instructions	Rxn-10 Raman spectroscopic probe Brief Operating Instructions
TI01629C	Technical Information	Rxn-10 Raman spectroscopic probe Technical Information

Table 11. Supplementary documentation

14 Index

- accessories, 5, 10, 13, 17
- adapters, 13, 15, 17
- CDRH compliance, 5, 8
- certification, 8
 - compliance, 5, 8
 - CSA, 5
- electrical connection, 6
- export compliance, 4
- fiber cable
 - cleaning, 20
 - EO, 5, 11, 12
 - FC, 5, 11
 - laser interlock, 11
 - minimum bend radius, 8, 22
- glossary, 5
- IEC compliance, 5, 7, 8, 16
- laser interlock, 8, 11, 12, 19
- MPE
 - ocular exposure, 23
 - skin exposure, 24
- probe
 - additional documents, 25
 - bIO-Optics, 9, 13
 - clamp, 13
 - designated use, 6
 - immersion optics, 9, 13
 - installation, 6, 16
 - materials of construction, 22
 - non-contact optics, 9, 13, 15
 - operation, 18
 - receipt, 10
 - single use system, 9, 14
 - troubleshooting, 19
 - verification, 17
- Raman RunTime, 17
- repair, 21
- safety, 7
 - basic, 6
 - eye, 16, 23
 - laser, 7, 8
 - operational, 6
 - product, 7
 - service, 7
 - skin, 16, 24
 - workplace, 6
- specifications, 22
 - diameter, 22
 - fiber cable
 - length, 22
 - humidity, 22
 - laser power, 19, 22
 - length, 22
 - temperature, 22
 - weight, 22
- symbols, 4
- technical data, 22

www.addresses.endress.com
