

# Safety Instructions

## Liquiphant FailSafe

### FTL80, FTL81, FTL85

II 1/2 G Ex db IIC T6 Ga/Gb





# Liquiphant FailSafe FTL80, FTL81, FTL85

## Table of contents

Associated documentation .....	4
Supplementary documentation .....	4
Manufacturer's certificates .....	4
Manufacturer address .....	4
Other standards .....	4
Extended order code .....	5
Safety instructions: General .....	8
Safety instructions: Special conditions .....	8
Safety instructions: Installation .....	9
Safety instructions: Ex d joints .....	10
Safety instructions: Zone 0 .....	11
Explosion protection with heat insulation .....	11
Temperature tables .....	12
Connection data .....	16

<b>Associated documentation</b>	<p>This document is an integral part of the following Operating Instructions: BA01037F/00</p>
<b>Supplementary documentation</b>	<p>Explosion-protection brochure: CP00021Z/11 The Explosion-protection brochure is available:</p> <ul style="list-style-type: none"><li>■ In the download area of the Endress+Hauser website: <a href="http://www.endress.com">www.endress.com</a> -&gt; Downloads -&gt; Brochures and Catalogs -&gt; Text Search: CP00021Z</li><li>■ On the CD for devices with CD-based documentation</li></ul>
<b>Manufacturer's certificates</b>	<p><b>UK Declaration of Conformity</b></p> <p>Declaration Number: UK_00254</p> <p>The UK Declaration of Conformity is available: In the download area of the Endress+Hauser website: <a href="http://www.endress.com">www.endress.com</a> -&gt; Downloads -&gt; Declaration -&gt; Type: UKCA Declaration -&gt; Product Code: ...</p> <p><b>UKCA type-examination certificate</b></p> <p>Certificate number: CML 21UKEX2637X</p> <p>List of applied standards: See UK Declaration of Conformity.</p>
<b>Manufacturer address</b>	<p>Endress+Hauser SE+Co. KG Hauptstraße 1 79689 Maulburg, Germany Address of the manufacturing plant: See nameplate.</p>
<b>Other standards</b>	<p>Among other things, the following standards shall be observed in their current version for proper installation:</p> <ul style="list-style-type: none"><li>■ IEC/EN 60079-14: "Explosive atmospheres - Part 14: Electrical installations design, selection and erection"</li><li>■ EN 1127-1: "Explosive atmospheres - Explosion prevention and protection - Part 1: Basic concepts and methodology"</li></ul>

## Extended order code

The extended order code is indicated on the nameplate, which is affixed to the device in such a way that it is clearly visible. Additional information about the nameplate is provided in the associated Operating Instructions.

### Structure of the extended order code

FTL8x	-	*****	+	A*B*C*D*E*F*G*..
<i>(Device type)</i>		<i>(Basic specifications)</i>		<i>(Optional specifications)</i>

\* = Placeholder

At this position, an option (number or letter) selected from the specification is displayed instead of the placeholders.

#### *Basic specifications*

The features that are absolutely essential for the device (mandatory features) are specified in the basic specifications. The number of positions depends on the number of features available. The selected option of a feature can consist of several positions.

#### *Optional specifications*

The optional specifications describe additional features for the device (optional features). The number of positions depends on the number of features available. The features have a 2-digit structure to aid identification (e.g. JA). The first digit (ID) stands for the feature group and consists of a number or a letter (e.g. J = Test, Certificate). The second digit constitutes the value that stands for the feature within the group (e.g. A = 3.1 material (wetted parts), inspection certificate).

More detailed information about the device is provided in the following tables. These tables describe the individual positions and IDs in the extended order code which are relevant to hazardous locations.

### Extended order code: Liquiphant FailSafe



The following specifications reproduce an extract from the product structure and are used to assign:

- This documentation to the device (using the extended order code on the nameplate).
- The device options cited in the document.

#### *Device type*

FTL80, FTL81, FTL85

*Basic specifications*

Position 1, 2 (Approval)		
Selected option	Description	
FTL8x	UC	UK Ex II 1/2 G Ex db IIC T6 Ga/Gb

Position 3 (Electronics, Output)		
Selected option	Description	
FTL8x	S	FEL85; 2-wire, 4-20 mA

Position 4 (Display, Operation)		
Selected option	Description	
FTL8x	A	LED; switch

Position 5 (Housing)		
Selected option	Description	
FTL8x	D	F13 Alu, IP66/68 NEPA Type 4X/6P Encl.
	E	T13 Alu, separate conn. compartment, IP66/68 NEPA Type 4X/6P Encl.
	I	F27 316L, IP66/68 NEPA Type 4X/6P Encl.

Position 6 (Electrical Connection)		
Selected option	Description	
FTL8x	B	Thread M20
	C	Thread G1/2
	D	Thread NPT1/2
	E	Thread NPT3/4

<b>Position 7 (Application)</b>		
<b>Selected option</b>		<b>Description</b>
FTL80	A	Process max. 150 °C/302 °F, 64 bar/928 psi
	C	Process max. 230 °C/446 °F, 100 bar/1450 psi; incl. gas-tight feed through
	D	Process max. 280 °C/536 °F, 100 bar/1450 psi; incl. gas-tight feed through
	Y	Process max. 300 °C/572 °F, 100 bar/1450 psi
FTL81	A	Process max. 150 °C/302 °F, 64 bar/928 psi
	B	Process max. 150 °C/302 °F, 100 bar/1450 psi
	C	Process max. 230 °C/446 °F, 100 bar/1450 psi; incl. gas-tight feed through
	D	Process max. 280 °C/536 °F, 100 bar/1450 psi; incl. gas-tight feed through
	Y	Process max. 300 °C/572 °F, 100 bar/1450 psi
FTL85	N	ECTFE, Process max. 120 °C/248 °F, 40 bar/580 psi
	P	PFA, Process max. 150 °C/302 °F, 40 bar/580 psi
	T	Enamel, Process max. 150 °C/302 °F, 25 bar/362 psi

<b>Position 9 (Surface Refinement)</b>		
<b>Selected option</b>		<b>Description</b>
FTL85	N	Coating ECTFE
	P	Coating PFA (Edlon)
	Q	Coating PFA (RubyRed)
	R	Coating PFA (conductive)
	T	Coating Enamel

### *Optional specifications*

<b>ID Mx (Sensor Design)</b>		
<b>Selected option</b>		<b>Description</b>
FTL8x	MP	Ambient temperature -50 °C/-58 °F
	MQ	Ambient temperature -60 °C/-76 °F
	MR	Temperature separator
	MS	Pressure tight feed through, incl. temperature separator

ID Nx (Accessory Mounted)		
Selected option		Description
FTL8x	ND	Cover, housing F13 Alu, window
	NE	Cover, housing T13 Alu, window

**Safety instructions:**  
**General**

- Staff must meet the following conditions for mounting, electrical installation, commissioning and maintenance of the device:
  - Be suitably qualified for their role and the tasks they perform
  - Be trained in explosion protection
  - Be familiar with national regulations
- Install the device according to the manufacturer's instructions and national regulations.
- Do not operate the device outside the specified electrical, thermal and mechanical parameters.
- Only use the device in media to which the wetted materials have sufficient durability.
- Avoid electrostatic charging:
  - Of plastic surfaces (e.g. enclosure, sensor element, special varnishing, attached additional plates, ..)
  - Of isolated capacities (e.g. isolated metallic plates)
- Refer to the temperature tables for the relationship between the permitted ambient temperature for the sensor and/or transmitter, depending on the range of application and the temperature class.
- Modifications to the device can affect the explosion protection and must be carried out by staff authorized to perform such work by Endress+Hauser.

**Safety instructions:**  
**Special conditions**

Permitted ambient temperature range at the electronics enclosure:  
 $-60\text{ °C} \leq T_a \leq +70\text{ °C}$

*Optional specifications Nx = ND, NE*

Restriction to  $-50\text{ °C} \leq T_a \leq +70\text{ °C}$ .

- Observe the information in the temperature tables.
- In the case of process connections made of polymeric material or with polymeric coatings, avoid electrostatic charging of the plastic surfaces.
- In the event of additional or alternative special varnishing on the enclosure or other metal parts:
  - Observe the danger of electrostatic charging and discharge.
  - Do not rub surfaces with a dry cloth.

*Basic specification, Position 5 = D, E*

Avoid sparks caused by impact and friction.



*Basic specification, Position 5 = I*  
Covers with glass window not permitted.

### Device group IIC

A probe coated with non-conductive material can be used if avoiding electrostatic charging (e.g. through friction, cleaning, maintenance, strong medium flow).

### Device group IIB

A probe coated with non-conductive material can be used.

## Safety instructions: Installation

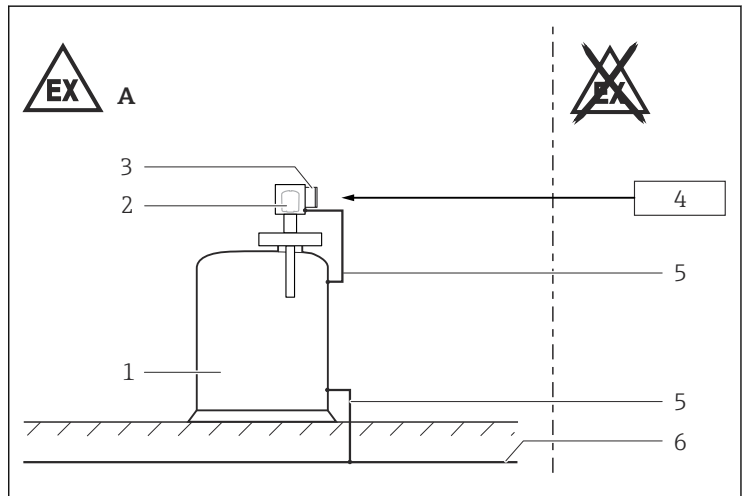

A0025537

### 1

- A Zone 1
- 1 Tank; Zone 0, Zone 1
- 2 Electronic insert, electronics compartment Ex d
- 3 Connection compartment Ex d (only Basic specification, Position 5 = E)
- 4 Power supply
- 5 Potential equalization line
- 6 Potential equalization

- At high medium temperatures, note flange pressure load capacity as a factor of temperature.
- Perform the following to achieve the degree of protection IP66/68:
  - Screw the cover tight.
  - Mount the cable entry correctly.
- Observe the maximum process conditions according to the manufacturer's Operating Instructions.

- Install the device to exclude any mechanical damage or friction during the application. Pay particular attention to flow conditions and tank fittings.
- Support extension tube of the device if a dynamic load is expected.
- Only use certified cable entries suitable for the application. Observe national regulations and standards. Accordingly, the connection terminal does not include any ignition sources.
- When operating the transmitter enclosure at an ambient temperature under  $-20\text{ }^{\circ}\text{C}$ , use appropriate cables and cable entries permitted for this application.
- When connecting through a conduit entry approved for this purpose, mount the associated sealing unit directly at the enclosure.
- Seal unused entry glands with approved sealing plugs that correspond to the type of protection. The plastic transport sealing plug does not meet this requirement and must therefore be replaced during installation.
- Continuous service temperature of the connecting cable:  
 $-40\text{ }^{\circ}\text{C}$  to  $\geq +85\text{ }^{\circ}\text{C}$ ; in accordance with the range of service temperature taking into account additional influences of the process conditions ( $T_{a,\text{min}}$ ), ( $T_{a,\text{max}} + 20\text{ K}$ ).
- In potentially explosive atmospheres:
  - Do not disconnect the electrical connection of the power supply circuit when energized.
  - Do not open the connection compartment cover and the electronics compartment cover when energized.
- Before operation:
  - Screw in the cover all the way.
  - Tighten the securing clamp on the cover.

### Accessory high pressure sliding sleeve

The high pressure sliding sleeve can be used for a continuous setting of the switch point and is suited for zone separation if mounted properly (see Operating Instructions).

### Non-sparking

In potentially explosive atmospheres: Do not disconnect electrical connections when energized.

### Potential equalization

Integrate the device into the local potential equalization.

### Safety instructions: Ex d joints

- If required or if in doubt: ask manufacturer for specifications.
- Flameproof joints are not intended to be repaired.

## Safety instructions:

### Zone 0

- In the event of potentially explosive vapor/air mixtures, only operate the device under atmospheric conditions.
  - Temperature:  $-20$  to  $+60$  °C
  - Pressure: 80 to 110 kPa (0.8 to 1.1 bar)
  - Air with normal oxygen content, usually 21 % (V/V)
- If no potentially explosive mixtures are present, or if additional protective measures have been taken, the device may also be operated under non-atmospheric conditions in accordance with the manufacturer's specifications.
- When using under non-atmospheric pressures and non-atmospheric temperatures: The sensor part of the device approved for Zone 0 does not cause any ignition hazards.
- Only use the device in media to which the wetted materials have sufficient durability (e.g. process connection seal).

## Explosion protection with heat insulation

Device type FTL80, FTL81, Basic specification, Position 7 = C, D, Y

- While observing the "temperature derating", the device is suitable for process temperatures up to 300 °C.
- When operating, ensure that you rule out contact between hot component surfaces and potentially explosive atmospheres beyond the limits of the corresponding temperature class. Suitable measures: e.g. thermal insulation at container and/or pipes.
- The temperature of 85 °C specified at the reference point may not be exceeded.
- To protect the electronics, observe the specified ambient temperature at the electronics enclosure.

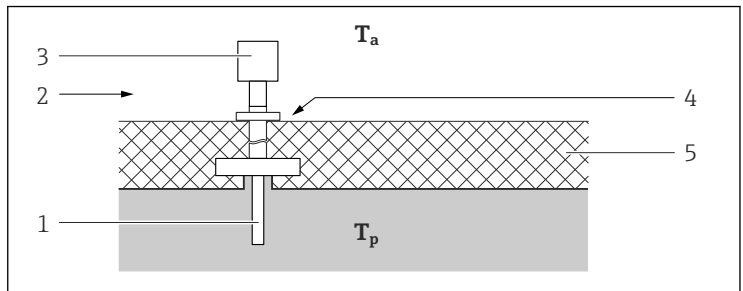

A0025541

2

$T_a$  Ambient temperature

$T_p$  Process temperature

1 Sensor

2 Temperature class, e.g. T6

3 Enclosure

4 Reference point: max.  $+85$  °C

5 E.g. thermal insulation

## Temperature tables

### Ambient temperature electronics

When used outside Zone 0
-60 to +70 °C <i>Optional specifications Nx = ND, NE: -50 to +70 °C</i>

### Process temperature sensor

When used in Zone 0
-20 to +60 °C

Device type FTL80, FTL81, Basic specification, Position 7 = A, B, C, D, Y



When used outside Zone 0
-50 to +150 °C (A, B)
-60 to +230 °C (C)
-60 to +280 °C (D)
-60 to +300 °C (Y)

Device type FTL85, Basic specification, Position 7 = N, P, T



When used outside Zone 0
-50 to +120 °C (N)
-50 to +150 °C (P, T)

The dependency of the ambient and process temperatures upon the temperature class:



Device type FTL80, FTL81, Basic specification, Position 7 = A, B

Temperature class	Process temperature $T_p$ (process): sensor	Ambient temperature $T_a$ (ambient): electronics
T6	-50 to +85 °C	-60 to +70 °C <i>Optional specifications Nx = ND, NE: -50 to +70 °C</i>
T5	-50 to +100 °C	-60 to +70 °C <i>Optional specifications Nx = ND, NE: -50 to +70 °C</i>
T4	-50 to +135 °C	Additional temperature range for sensors with Optional specifications Mx = MR, MS
T3	-50 to +150 °C	→  3,  14

*Device type FTL80, FTL81, Basic specification, Position 7 = C, D, Y*

Temperature class	Process temperature $T_p$ (process): sensor	Ambient temperature $T_a$ (ambient): electronics
T6	-60 to +85 °C	-60 to +70 °C <i>Optional specifications Nx = ND, NE:</i> -50 to +70 °C
T5	-60 to +100 °C	-60 to +70 °C <i>Optional specifications Nx = ND, NE:</i> -50 to +70 °C For restrictions →  4,  15
T4	-60 to +135 °C	
T3	-60 to +200 °C	
T2	-60 to +230 °C (C) -60 to +280 °C (D) -60 to +300 °C (Y)	

*Device type FTL85, Basic specification, Position 7 = N, P, T*

Temperature class	Process temperature $T_p$ (process): sensor	Ambient temperature $T_a$ (ambient): electronics
T6	-50 to +85 °C	-60 to +70 °C <i>Optional specifications Nx = ND, NE:</i> -50 to +70 °C
T5	-50 to +100 °C	-60 to +70 °C <i>Optional specifications Nx = ND, NE:</i> -50 to +70 °C Additional temperature range for sensors with <i>Optional specifications Mx = MR, MS</i> →  3,  14
T4	-50 to +120 °C (N)	
	-50 to +135 °C (P, T)	
T3	-50 to +150 °C (P, T)	

Device type FTL80, FTL81, Basic specification, Position 7 = A, B

Device type FTL85, Basic specification, Position 7 = N, P, T

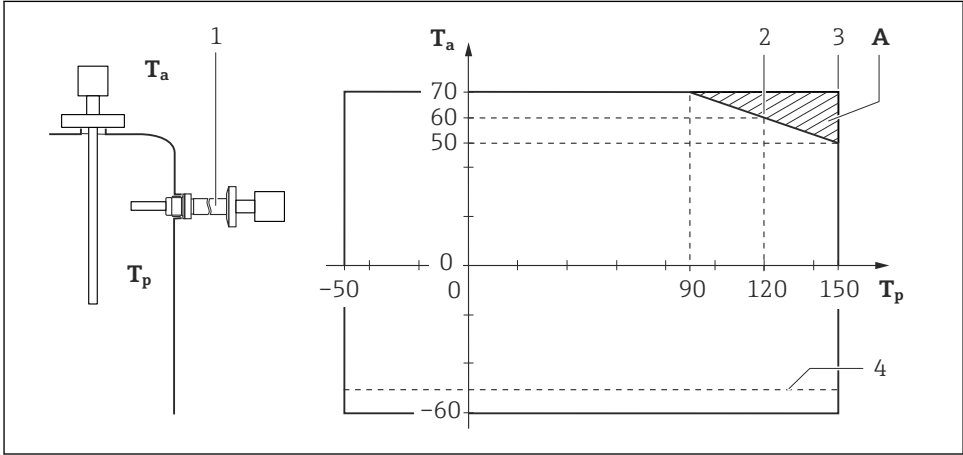

A0025554

3

$T_a$  Ambient temperature

$T_p$  Process temperature

A Additional temperature range for sensors with Optional specifications Mx = MR, MS

1 Temperature separator or pressure tight feed through

2 ECTFE

3 PFA, Enamel

4  $T_a$  for Optional specifications Nx = ND, NE: -50 to +70 °C

## Device type FTL80, FTL81, Basic specification, Position 7 = C, D, Y

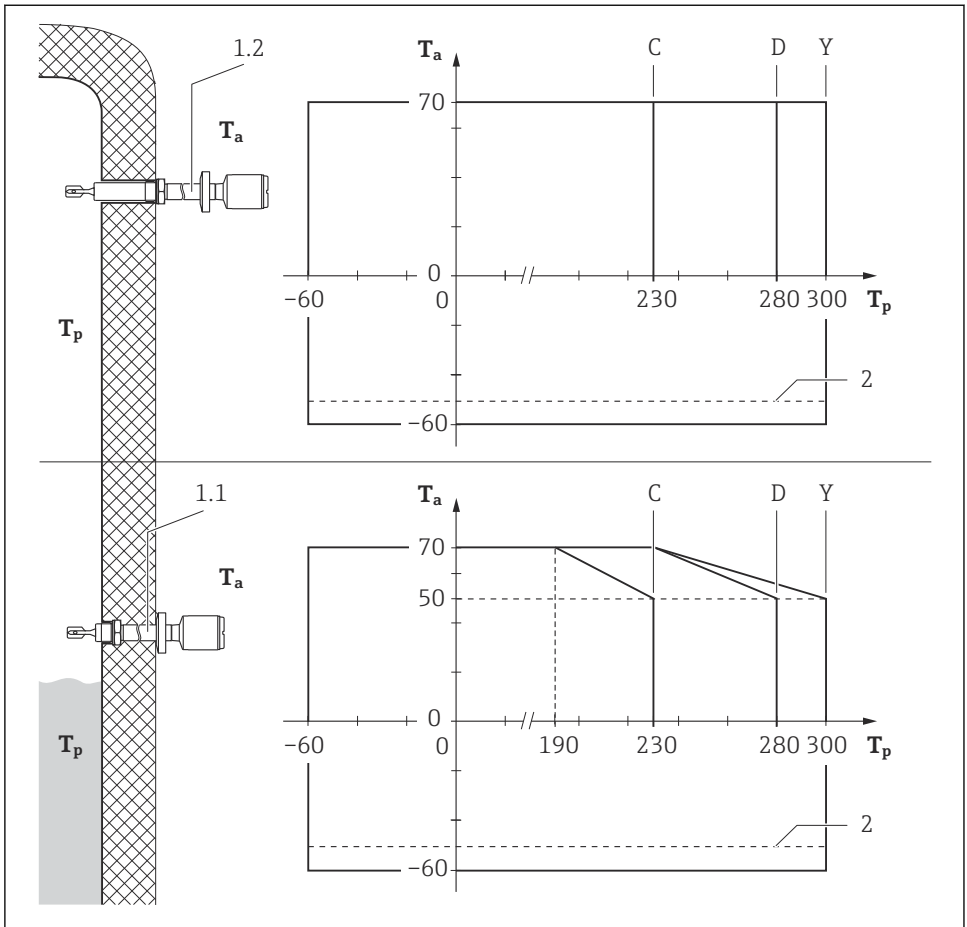

A0025634

4

$T_a$  Ambient temperature

$T_p$  Process temperature

1 Temperature separator:

1.1 insulated

1.2 free-standing

2  $T_a$  for Optional specifications Nx = ND, NE: -50 to +70 °C

## Connection data Ex db



Only connect the device to terminals 1 and 2 or terminals 2 and 3, respectively.

Terminal 1 (-) (MAX safety) Terminal 2 (+) Terminal 3 (-) (MIN safety)
Power supply  $U_e = 30 V_{DC}$ $U_m = 250 V_{AC}$ $I_{Nom} = 4 \text{ to } 20 \text{ mA}$ $P_{max} \leq 660 \text{ mW}$

### Cable entry

Cable gland: *Basic specification, Position 6 = B*

Thread	Clamping range	Material	Sealing insert	O-ring
M20x1,5	$\varnothing 8 \text{ to } 10.5 \text{ mm}^{1)}$ ( $\varnothing 6.5 \text{ to } 13 \text{ mm}^{2)}$	Ms, nickel-plated	LSR (Silicone)	EPDM ( $\varnothing 17 \times 2$ )

- 1) Standard
- 2) Separate clamping inserts available



- The tightening torque refers to cable glands installed by the manufacturer:
  - Recommended torque to connect the cable gland into the enclosure: 3.75 Nm
  - Recommended torque to tighten the cable into the cable gland: 3.5 Nm
  - Maximum torque to tighten the cable into the cable gland: 10 Nm
  - This value may be different depending on the type of cable. However, the maximum value must not be exceeded.
- Only suitable for fixed installation. The operator must pay attention to a suitable strain relief of the cable.
- The cable glands are suitable for a low risk of mechanical danger (4 Joule) and must be mounted in a protected position if larger impact energy levels are expected.
- To maintain the ingress protection of the enclosure: Install the enclosure cover, cable glands and blind plugs correctly.











71540200

[www.addresses.endress.com](http://www.addresses.endress.com)

---