



# Brief Operating Instructions iTEMP TMT31

Temperature transmitter

These Instructions are Brief Operating Instructions; they are not a substitute for the Operating Instructions pertaining to the device.  
For detailed information, refer to the Operating Instructions and other documentation.

Available for all device versions via:

- Internet: [www.endress.com/deviceviewer](http://www.endress.com/deviceviewer)
- Smart phone/Tablet: Endress+Hauser Operations App

## Basic safety instructions

### Requirements for the personnel

The personnel performing installation, commissioning, diagnostics and maintenance must satisfy the following requirements:

- ▶ Trained, qualified specialists must be suitably qualified to perform this function and task
- ▶ Are authorized by the plant owner/operator
- ▶ Are familiar with federal/national regulations
- ▶ They must have read and understood the instructions in the manual, supplementary documentation and certificates (depending on the application) prior to starting work
- ▶ They must follow instructions and comply with basic conditions

The operating personnel must satisfy the following requirements:

- ▶ They must be suitably trained and authorized by the plant operator to meet the requirements of the task
- ▶ They must follow the instructions in this manual

### Intended use

The device is a universal and configurable temperature transmitter with a sensor input for resistance thermometers (RTD). The head transmitter version of the device is intended for mounting in a terminal head (flat face) as per DIN EN 50446. It is also possible to mount the device on a DIN rail using the optional DIN rail clip.

### Operational safety

- ▶ Operate the device only if it is in proper technical condition, free from errors and faults.
- ▶ The operator is responsible for interference-free operation of the device.

### Hazardous area

To eliminate a danger for persons or for the facility when the device is used in the hazardous area (e.g. explosion protection or safety equipment):

- ▶ Based on the technical data on the nameplate, check whether the ordered device is permitted for the intended use in the hazardous area. The nameplate can be found on the side of the transmitter housing.
- ▶ Observe the specifications in the separate supplementary documentation that is an integral part of these instructions.

### NOTICE

- ▶ The device must be powered only by a power unit that operates using a limited-energy circuit in accordance with UL/EN/IEC 61010-1, Section 9.4 and the requirements in Table 18.

## Mounting

### Mounting requirements

#### Dimensions

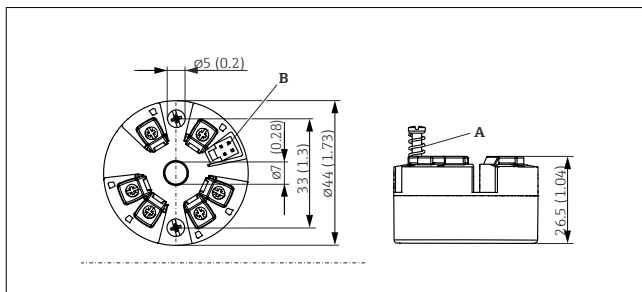

1 Head transmitter version with screw terminals. Dimensions in mm (in)

- A Spring travel  $L \geq 5$  mm (not for US - M4 securing screws)
- B CDI interface for connecting a configuration tool



The same dimensions apply to the version with push-in terminals.  
Exception: housing height  $H = 30$  mm (1.18 in).

### Mounting location

- ▶ In the terminal head, flat face, as per DIN EN 50446, direct mounting on insert with cable entry (middle hole 7 mm)
- ▶ With DIN rail clip on DIN rail as per IEC 60715, TH35



When installing the device in a terminal head, make sure there is enough space in the terminal head!

### Important ambient conditions

- ▶ Ambient temperature:  $-40$  to  $+85$  °C ( $-40$  to  $185$  °F)
- ▶ Head transmitter in accordance with climate class C1, DIN rail transmitter in accordance with B2 as per EN 60654-1
- ▶ Condensation as per IEC 60068-2-33 permitted for head transmitter, not permitted for DIN rail transmitter
- ▶ Max. rel. humidity: 95% as per IEC 60068-2-30
- ▶ Degree of protection:  
Head transmitter with screw terminals: IP 00, with push-in terminals: IP 30.  
In installed state, depends on the terminal head or field housing used.

## Mounting the device

A Phillips head screwdriver is required to mount the head transmitter:

- Maximum torque for securing screws = 1 Nm (¾ foot-pound), screwdriver: Pozidriv Z2
- Maximum torque for screw terminals = 0.35 Nm (¼ foot-pound), screwdriver: Pozidriv Z1

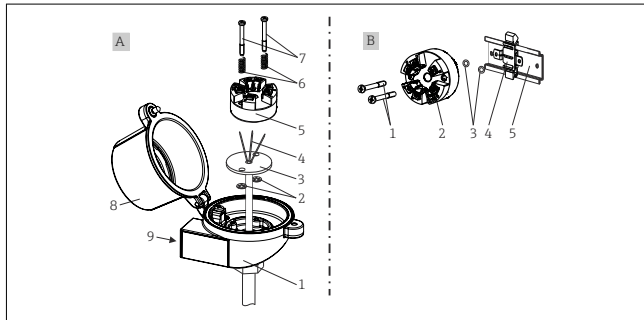

2 Head transmitter mounting

Procedure for mounting in a terminal head, item A:

1. Open the terminal head cover (8) on the terminal head.
2. Guide the connection wires (4) of the insert (3) through the center hole in the head transmitter (5).
3. Fit the mounting springs (6) on the mounting screws (7).
4. Guide the mounting screws (7) through the side boreholes of the head transmitter and the insert (3). Then fix both mounting screws with the snap rings (2).
5. Then tighten the head transmitter (5) along with the insert (3) in the terminal head.
6. After wiring, close the terminal head cover (8) tightly again.

## Electrical connection

### CAUTION

- ▶ Switch off the power supply before installing or connecting the device. Non-compliance may result in the destruction of parts of the electronics.
- ▶ Do not occupy the CDI connection. An incorrect connection can destroy the electronics.

### Quick wiring guide

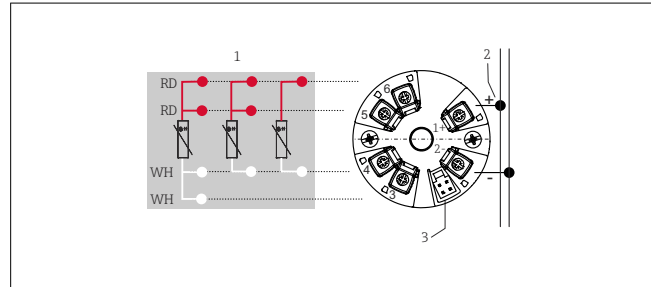

3 Terminal assignment of head transmitter

- 1 RTD sensor input: 4-, 3- and 2-wire
- 2 Power supply
- 3 CDI interface

### NOTICE

- ▶ ⚡ ESD - Electrostatic discharge. Protect the terminals from electrostatic discharge. Non-compliance may result in the destruction or malfunction of parts of the electronics.

Maximum torque for screw terminals = 0.35 Nm (¼ lbf ft), screwdriver: Pozidriv Z1