

Technical Information

Solitrend MMP60

Material moisture measurement



Continuous measurement in low-density media

Application

Moisture measurement in bulk solids with low density from 0.1 to 1 g/cm³ (0.004 to 0.036 lb/in³), such as sawdust, woodchips, biomass, pellets, granules

Your benefits

- Deep material penetration to 85 mm (3.35 in)
- High resolution even with low moisture content
- Precise in bulk densities down to 0.1 g/cm³ (0.004 lb/in³)
- Optional high-temperature version up to 120 °C (248 °F) thanks to remote electronics module
- Integrated transmitter for simple system integration
- Surface and capillary moisture measurement

Table of contents

About this document	3	Documentation	12
Symbols	3	Brief Operating Instructions (KA)	12
Function and system design	3	Operating Instructions (BA)	12
Measuring principle	3	Safety Instructions (XA)	12
Calibration	4		
Operating mode	4		
Communication	4		
Input	4		
Measured variable	4		
Measuring range	4		
Output	5		
Analog	5		
Digital	5		
Linearization	5		
Power supply	5		
Terminal assignment	5		
Supply voltage	5		
Power consumption	5		
Power supply failure	5		
Electrical connection	6		
Potential equalization	6		
Cable specification	6		
Performance characteristics	7		
Reference operating conditions	7		
Measured value resolution	7		
Mounting	8		
Mounting location	8		
Installation instructions	8		
Environment	9		
Ambient temperature range	9		
Storage temperature	9		
Operating altitude	9		
Degree of protection	9		
Process	9		
Process temperature range	9		
Mechanical construction	9		
Design	9		
Dimensions	10		
Weight	11		
Materials	11		
Certificates and approvals	11		
Ordering information	12		

About this document

Symbols

Safety symbols

DANGER

This symbol alerts you to a dangerous situation. Failure to avoid this situation will result in serious or fatal injury.

WARNING

This symbol alerts you to a dangerous situation. Failure to avoid this situation can result in serious or fatal injury.

CAUTION

This symbol alerts you to a dangerous situation. Failure to avoid this situation can result in minor or medium injury.

NOTICE

This symbol contains information on procedures and other facts which do not result in personal injury.

Symbols for certain types of information and graphics

Tip

Indicates additional information



Reference to graphic

Symbols in graphics

1, 2, 3, ...

Item numbers

A, B, C, ...

Views

Function and system design

Measuring principle

Time-domain reflectometry (TDR) is a radar-based dielectric measurement method where the transit time of electromagnetic pulses is determined to measure the water content. The devices consist of an aluminum housing with a stainless steel measuring cell. A transmitter is integrated in the housing. The high-frequency TDR pulse generated in the transmitter runs along a conductor and generates an electromagnetic field around this conductor and therefore in the material on the measurement surface. Using a patented measurement method, the transit time of this pulse is measured with a resolution of one picosecond (1×10^{-12}) in order to determine the moisture.

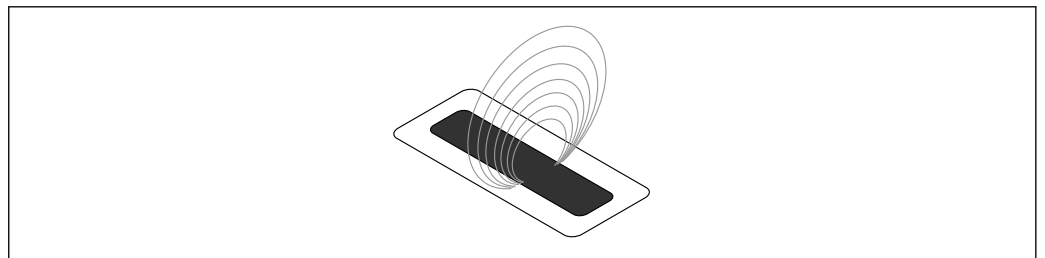

A0040293

 1 Wave guide; continuous, wide

The TDR method operates in the ideal frequency range between 600 MHz and 1.2 GHz.

The modular TDR technology enables moisture measurement in special applications, particularly in materials with a low bulk density, and can be adapted to individual applications due to the variable device design and accessories.

Calibration	The device is delivered with an appropriate calibration to suit the measuring task. A maximum of 15 different calibrations can be saved in the device and can be activated and adjusted via the remote display.
Operating mode	<p>The device is supplied from the factory with the CH mode for applications in the construction industry, and with the CA mode for general process applications. 6 different operating modes are available in the C measuring mode, depending on the application.</p> <ul style="list-style-type: none"> ▪ CS mode (Cyclic-Successive) For very short measurement cycles in the seconds range (e.g. 1 to 10 s) without averaging and without filter functions, and with up to 100 measurements per second internally and a cycle time of 250 ms at the analog output. ▪ CA mode (Cyclic Average Filter) Standard averaging for relatively fast but continuous measurement processes, with simple filtering and an accuracy of up to 0.1 %. The CA operating mode is also used to record raw values, without averaging and filtering, to be able to subsequently analyze the measured data and determine the optimum operating mode. ▪ CF mode (Cyclic Floating Average with Filter) Floating average for very slow and continuous measurement processes, with simple filtering and an accuracy of up to 0.1 %. Suitable for applications on a conveyor belt etc. ▪ CK mode (Cyclic with Boost Filter) For complex applications in mixers and dryers ▪ CC mode (Cyclic Cumulated) With automatic totalization of moisture quantity measurements in one batch process if no PLC controller is used ▪ CH mode (Cyclic Hold) Standard operating mode for applications in the construction industry. Similar to the CC mode, but with filtering and without totalization. The CH mode is ideal for very short batch times down to 2 s if the sensor has been installed under the silo discharge hatch. The CH mode performs filtering automatically. This allows drip water that forms in the silo to be filtered out of the measured value, for example.
Communication	The serial interface enables network operation of the device. A data bus protocol for the connection of multiple devices is implemented by default.

Input

Measured variable	<ul style="list-style-type: none"> ▪ Channel 1 Material moisture in % (variable setting) ▪ Channel 2 Conductivity 0 to 1 mS/cm or temperature 0 to 100 °C (32 to 212 °F), this also applies for the high-temperature version.
Measuring range	<ul style="list-style-type: none"> ▪ Material moisture The material moisture can be determined with a water content ranging from 0 to 100 %, in relation to the total mass ▪ Temperature sensor The temperature can be determined in the range from 0 to 100 °C (32 to 212 °F), this also applies for the high-temperature version. ▪ Material conductivity Material conductivity can be determined up to a maximum value of 1 mS/cm

Output

Analog

- Channel 1 (material moisture):
0 to 20 mA / 4 to 20 mA
- Channel 2 (material conductivity or material temperature):
0 to 20 mA / 4 to 20 mA



The analog outputs can be set differently to the following possible options:

Moisture, temperature

Analog output 1 for moisture, output 2 for material temperature.

Moisture, conductivity

Analog output 1 for moisture, output 2 for conductivity from 0 to 20 mS/cm.

Moisture, temperature/conductivity

Analog output 1 for moisture, output 2 for material temperature and conductivity with automatic window switching.

Starting time

The first stable measured value is present at the analog output after approx. 1 s.

Digital

- Serial interface, RS485 standard
- IMP-Bus
 - Signal cable and operating voltage are galvanically isolated
 - Data transmission rate 9 600 Bit/s

Linearization

15 different calibration curves can be selected and saved via the remote display (optional).

Customer-specific calibrations can also be created and saved via the display.

Power supply

Terminal assignment

The device is supplied as standard with a 10-pin plug, series 26482, with IP67 protection.

Supply voltage

12 to 24 V_{DC}



Overvoltage

- ▶ Only use stabilized power units

Power consumption

<3 W

Power supply failure

The configuration is retained in the device.

Electrical connection

Connection example of 10-pin socket

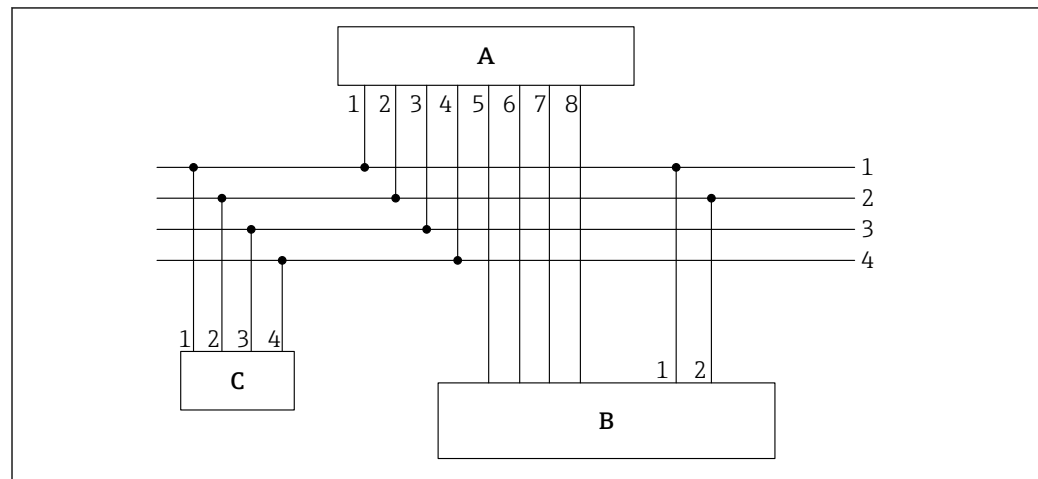

A0037418

2 Connection example, cable with 10-pin socket (on device side) and wire end ferrules at the cable end

- A Transmitter
 B PLC / distribution box
 C Remote display (optional)
- 1 0 V_{DC} power supply
 Wire color: blue (BU)
- 2 12 to 24 V_{DC} stabilized power supply
 Wire color: red (RD)
- 3 IMP-Bus RT
 Wire color: gray (GY) / pink (PK)
- 4 IMP-Bus COM
 Wire color: blue (BU) / red (RD)
- 5 1st current output (+), analog
 Wire color: green (GN)
- 6 1st current output (-), analog
 Wire color: yellow (YE)
- 7 2nd current output (+), analog
 Wire color: pink (PK)
- 8 2nd current output (-), analog
 Wire color: gray (GY)

i The moisture content determined and the conductivity / temperature can either be fed directly into a PLC via analog outputs 0 to 20 mA / 4 to 20 mA or queried via the serial interface (IMP-Bus).

Potential equalization

The shield is grounded at the device.

Cable specification

Connecting cables with a pre-assembled 10-pin socket on the device side are available in different standard lengths:

- 4 m (13 ft)
- 10 m (32 ft)
- 25 m (82 ft)

Shielded cable **UNITRONIC PUR CP**, twisted pairs $6 \times 2 \times 0.25 \text{ mm}^2$, PUR sheath resistant to oils and chemicals.

On request: Shielded cable **UNITRONIC ROBUST CP** $10 \times 0.25 \text{ mm}^2$, PUR sheath resistant to oils and chemicals.

Performance characteristics

Reference operating conditions

The following reference conditions apply to the performance characteristics:

- Ambient temperature: 24 °C (75 °F) ±5 °C (±9 °F)
- Ideal installation conditions:
 - Constant bulk density
 - Sufficient volume flow through the measuring field
 - No buildup

Measured value resolution

Measurement surface coverage / material height

A sufficient level (height) of material is needed over the measurement surface to ensure a precise measurement.

Minimum measurement surface coverage: 85 mm (3.35 in) (moisture-dependent)

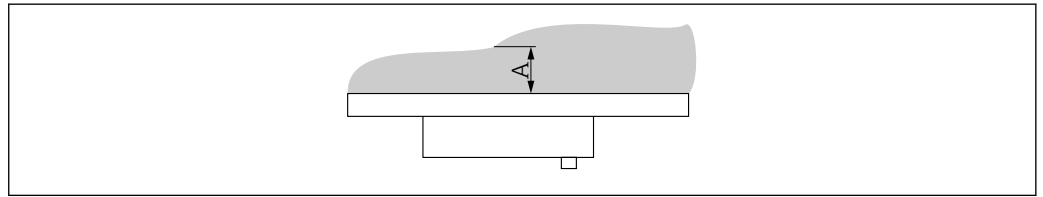

A0047910

3 Material height over the measurement surface

A Minimum measurement surface coverage

Measuring field propagation

≥ 85 mm (3.15 in) depending on material and moisture

Material moisture

Measuring range up to 100 % vol.

Conductivity

- The device delivers a characteristic value depending on the mineral concentration
- The conductivity range is reduced in material moisture measurement ranges > 50 %
- The conductivity value determined is uncalibrated and is primarily used to characterize the material being measured

Material temperature

Measuring range: 0 to 100 °C (32 to 212 °F)

The temperature is measured 3 mm below the measuring cell surface in the housing and can be output at analog output 2. Due to the internal heating of the electronics, the precise measurement of the material temperature is only possible to a limited extent.

Maximum measured error

Accuracy up to ±0.1 % under ideal, constant installation and material conditions.

The measured error depends on the operating mode and on the flow of material over the measurement surface. The longer the averaging time and the more stable the material density over the measurement surface, the lower the measured error.

Mounting

Mounting location

- The device must be installed at a point in the process in such a way that ensures a constant bulk density, as the bulk density directly affects the calculation of the water content. Where necessary, a bypass should be created or structural measures may be needed at the place of installation to ensure that the material flow, and therefore the bulk density, over the measurement surface is constant.
- The measuring field of the device must be completely covered by material and the material height must exceed the minimum layer of material covering on the measurement surface (depends on the device type and moisture).
- The flow of material over the measurement surface must be continuous. With the software, it is possible to automatically detect and bridge gaps in material flow in intervals of seconds.
- No material deposits or buildup may form on the measuring cell surface, as this would falsify the readings.



Longer averaging times increase the stability of the measured value.

Installation instructions

Installation in a screw conveyor

As the material in the screw conveyor is constantly compacted, the conveyor offers optimum conditions with regard to material flow and bulk density.

Installation at an installation angle of 30 ° in the rotation direction of the screw spiral ensures that there is sufficient material over the measurement surface.

As an option, part of the conveyor screw can be cut out so that a type of plug is formed and the material is compacted further.

The device can also be installed at the end of the screw conveyor, where material builds up, in an area where part of the screw of the conveyor is cut out.

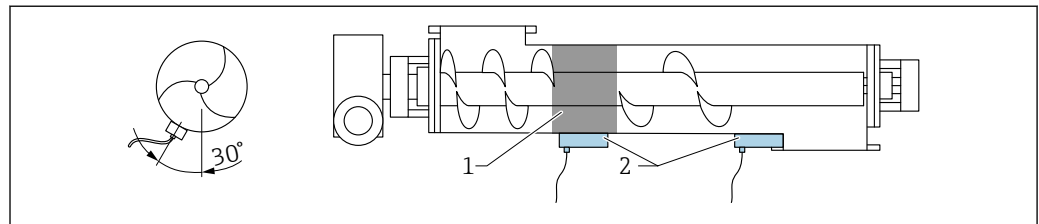

A0039404

4 Mounting in a screw conveyor

- 1 Cut-out from the spiral
- 2 Device installation position

Installation under a conveyor belt

Installation directly under a conveyor belt enables the moisture measurement of very hard-to-measure materials, or products that tend to stick and cake, such as ceramic powder, detergents and sand-lime.

Prerequisite:

- The conveyor belt must be made from plastic and must not have any metal parts.
- The thickness of the conveyor belt may not exceed 8 mm (0.31 in).
- The sliding plate (not included in the delivery) must be individually fitted and secured depending on the conveyor belt.
- The thickness of the conveyor belt must be taken into consideration with a basic calibration or a material calibration.



Discuss the specific application in advance with the responsible Support Agent!

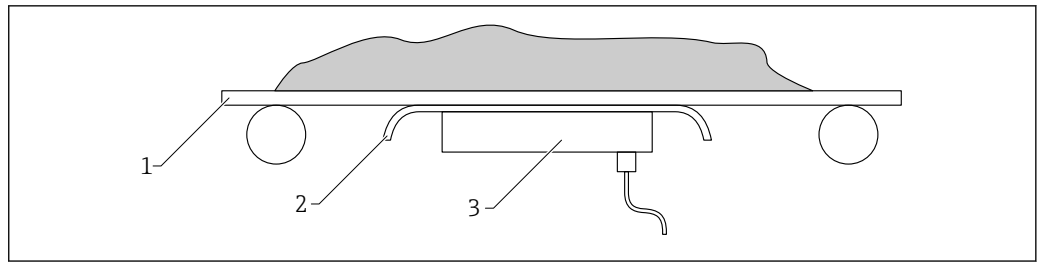

A0037466

5 Mounting under a conveyor belt

- 1 Conveyor belt
- 2 Sliding plate (not included in the delivery)
- 3 Device installation position

Environment

Ambient temperature range	At the housing: -40 to +70 °C (-40 to +158 °F)
Storage temperature	-40 to +70 °C (-40 to +158 °F)
Operating altitude	Up to 2 000 m (6 600 ft) above sea level
Degree of protection	IP67

Process

Process temperature range	<ul style="list-style-type: none"> ■ Standard, 0 to 70 °C (32 to 158 °F) ■ High-temperature version (electronics module located remotely in separate housing), 0 to 120 °C (32 to 248 °F)
	<p>i Moisture measurement below 0 °C (32 °F) is not possible. Frozen water (ice) cannot be detected.</p>

Mechanical construction

Design

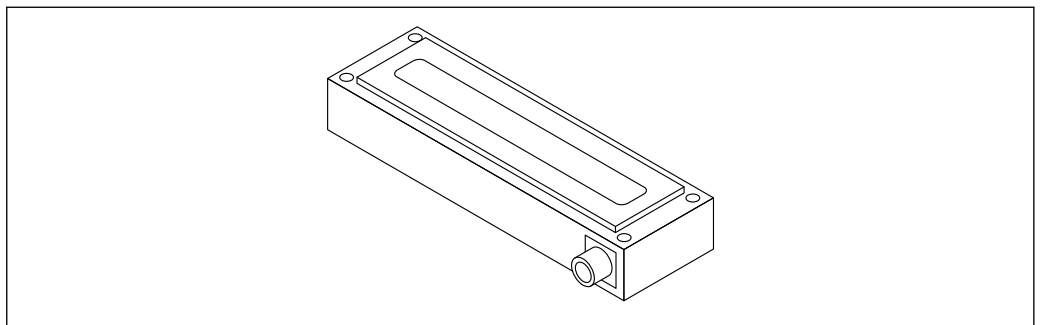

A0040363

6 Rectangular version

Remote electronics (accessories)

In the case of the order option **Accessories mounted: remote electronics 120 °C (248 °F)**, the electronics module is located in a separate housing and is connected using the HF cable that is permanently connected to the sensor.

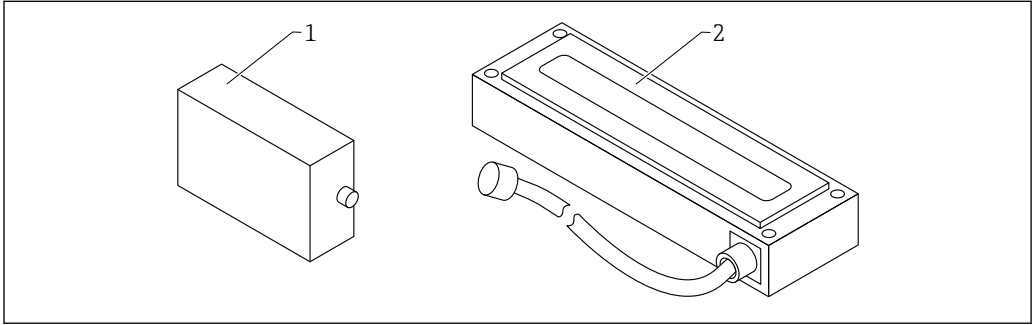

A0046896

- 1 Electronics housing
- 2 Rectangular sensor with HF cable 2.5 m (8.2 ft)

Dimensions

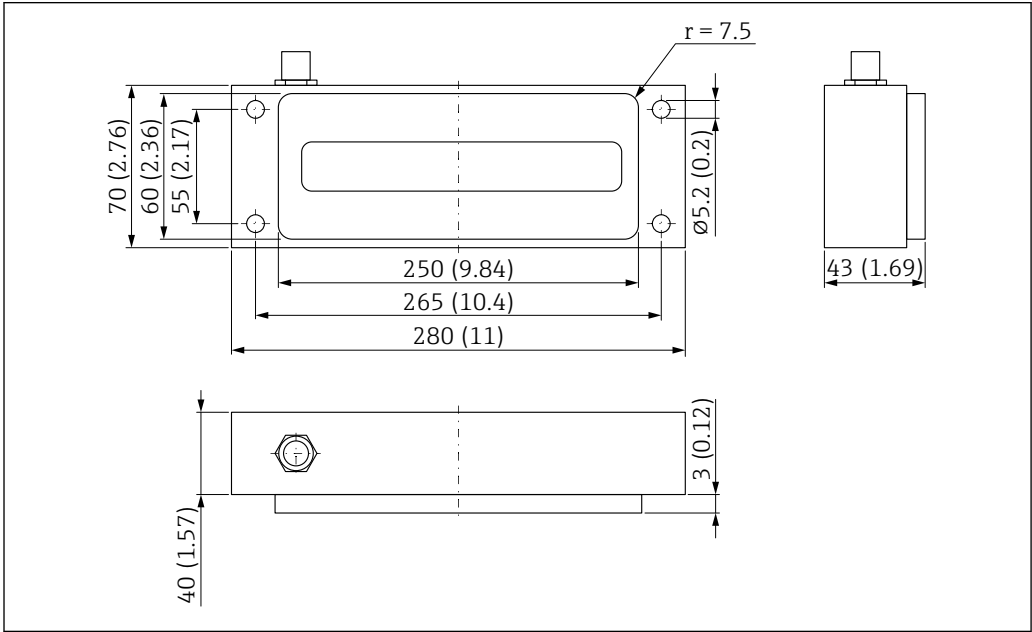

A0038452

7 Device dimensions. Unit of measurement mm (in)

Housing for remote electronics module

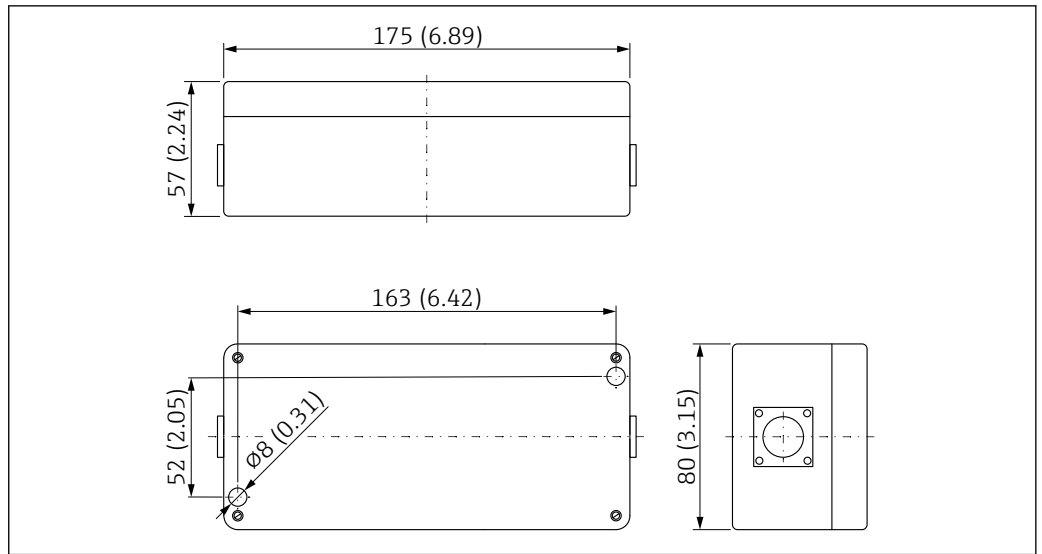

8 Dimensions of housing for remote electronics module. Unit of measurement mm (in)

A004492

Weight

Weight without packaging and accessories:
1.3 kg (2.87 lb)

Materials

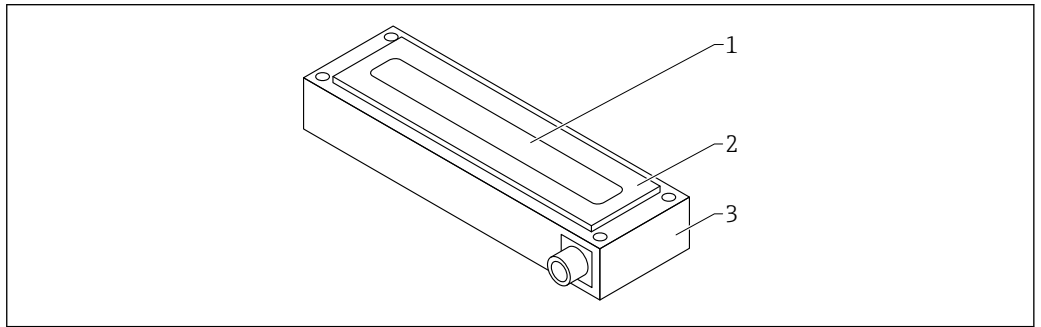

9 Materials

- 1 Wave guide; 1.4301 (V2A)
- 2 Measuring cell; TECAPEEK
- 3 Housing; aluminum

A0040364

Certificates and approvals

Current certificates for the product are available on the product page at www.endress.com.

1. Select the product using the filters and search field.
2. Open the product page.
3. Select **Downloads**.
4. Select **Technical Documentation**.
5. Select **ZE (Certificates)** as the filter

A list of all the certificates appears.

Current approvals for the product are available on the product page at www.endress.com.

1. Select the product using the filters and search field.
2. Open the product page.
3. Select **Downloads**.
4. Select **Approvals**.

A list of all the approvals appears.

Ordering information

Detailed ordering information is available from the nearest sales organization www.addresses.endress.com or in the Product Configurator under www.endress.com:

1. Select the product using the filters and search field.
2. Open the product page.

The **Configuration** button opens the Product Configurator.

Product Configurator - the tool for individual product configuration

- Up-to-the-minute configuration data
- Depending on the device: Direct input of measuring point-specific information such as measuring range or operating language
- Automatic verification of exclusion criteria
- Automatic creation of the order code and its breakdown in PDF or Excel output format
- Ability to order directly in the Endress+Hauser Online Shop

Documentation

The following types of documentation are available in the Download Area of the Endress+Hauser website (www.endress.com/downloads):

-  For an overview of the scope of the associated Technical Documentation, refer to the following:
 - *W@M Device Viewer* (www.endress.com/deviceviewer): Enter the serial number from the nameplate
 - *Endress+Hauser Operations App*: Enter the serial number from the nameplate or scan the matrix code on the nameplate

Brief Operating Instructions (KA)

Guide that takes you quickly to the 1st measured value

The Brief Operating Instructions contain all the essential information from incoming acceptance to initial commissioning.

Operating Instructions (BA)

Your reference guide

These Operating Instructions contain all the information that is required in various phases of the life cycle of the device: from product identification, incoming acceptance and storage, to mounting, connection, operation and commissioning through to troubleshooting, maintenance and disposal.

Safety Instructions (XA)

Depending on the approval, the following Safety Instructions (XA) are supplied with the device. They are an integral part of the Operating Instructions.

-  The nameplate indicates the Safety Instructions (XA) that are relevant to the device.



71550112

www.addresses.endress.com
