

# Technical Information

## Cleanfit CUA451

Manually operated retractable assembly for water, wastewater and process media

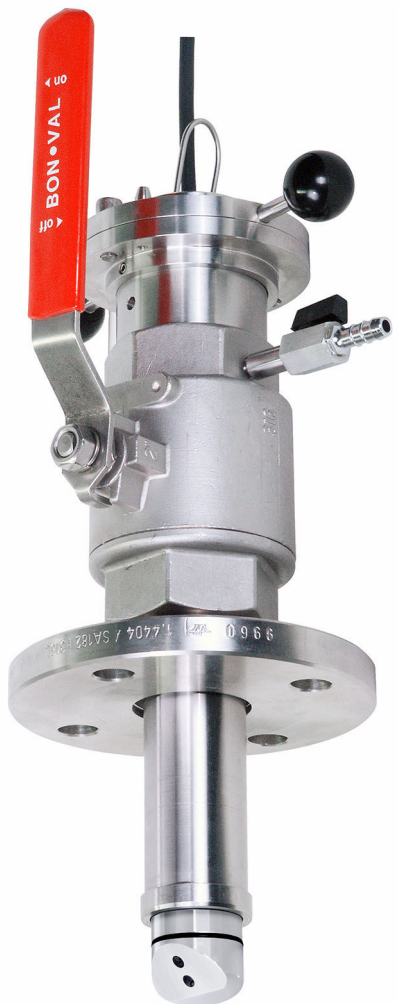

### Application

Drinking water and process water:

- Filter monitoring and filter backflushing
- Monitoring of phase separation processes
- Raw water monitoring
- Sludge treatment in water works

Wastewater treatment plants:

- Sludge in recirculation line
- Sludge centrifuge monitoring
- Primary sludge and sludge treatment

Process media from all kinds of industry:

- Raw water and process water monitoring
- Cooling water monitoring
- Recirculation lines
- Sludge treatment in water works

### Your benefits

- One assembly for all applications
- Sensor cleaned without interrupting the process
- Robust design: process pressure up to 10 bar (145 psi), manually operable up to 2 bar (29 psi)
- Process adaptation with 2" threaded adapter or flange

---

## Table of contents

<b>Function and system design</b> .....	<b>3</b>
Structure of the assembly .....	3
Structure of the sensor holder .....	3
Measuring system .....	5
<b>Installation</b> .....	<b>5</b>
Orientation .....	5
Installation instructions .....	6
<b>Environment</b> .....	<b>6</b>
Ambient temperature .....	6
<b>Process</b> .....	<b>6</b>
Medium temperature .....	6
Medium pressure .....	6
Pressure/temperature ratings .....	6
<b>Mechanical construction</b> .....	<b>7</b>
Dimensions .....	7
<b>Certificates and approvals</b> .....	<b>11</b>
CE/PED .....	11
<b>Ordering information</b> .....	<b>11</b>
Product page .....	11
Product Configurator .....	11
Scope of delivery .....	12
<b>Accessories</b> .....	<b>13</b>
Device-specific accessories .....	13
Service-specific accessories .....	14

## Function and system design

The assembly is operated manually.

**i** The vent cock or the the rinse connections (if used) are in open contact with the medium in the measuring position and when the assembly is retracted/inserted, and are therefore exposed to the process pressure.

The vent cock or the rinse connections (if used) must be closed when inserting/retracting the assembly.

In the service position (sensor moved back into the assembly as far as possible and ball valve closed), the assembly is sealed from the process by the ball valve.

This means that cleaning, calibration or sensor replacement can be performed without interrupting the process.

The assembly can be inserted/retracted manually at process conditions up to a process pressure of approx. 2 bar (29 psi).

### Structure of the assembly

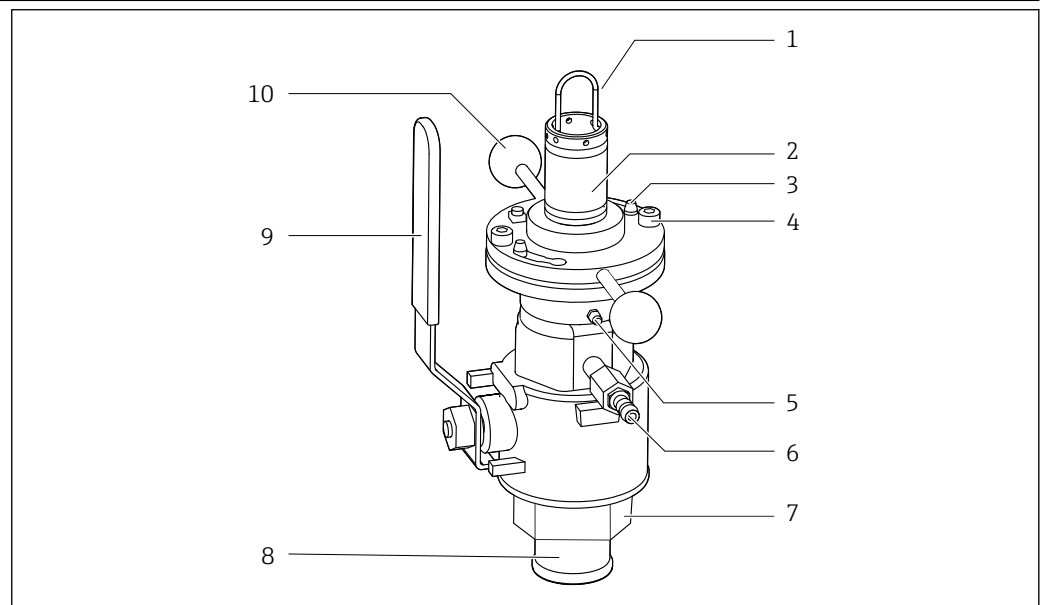

**i** 1 Assembly in operational state (ball valve open)

- 1 Bracket for sensor holder
- 2 Sensor holder
- 3 Bayonet lock
- 4 Securing screws
- 5 Grease nipple
- 6 Ball valve/valve for venting or rinse connection
- 7 Process connection
- 8 Retraction pipe
- 9 Hand lever for opening/closing the ball valve
- 10 Handles

**i** An additional rinse chamber valve can be mounted in the locking screw opposite the vent valve.

### Structure of the sensor holder

The sensor holder is used to position the sensor correctly in order to ensure correct measuring accuracy.

If the sensor is not positioned correctly, the ball valve may be blocked or the sensor may be located in the dead space as a result.

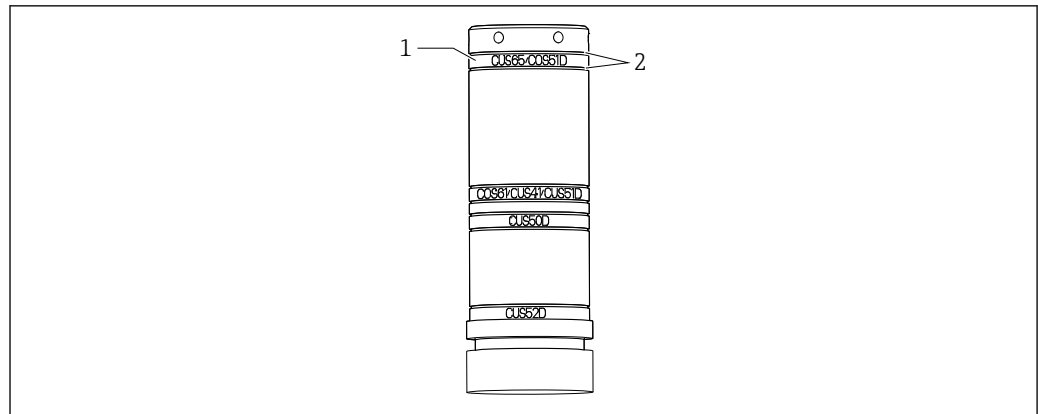

A0038451

**2** Short sensor holder

- 1 Mounting position of the bayonet nut to hold the relevant sensor  
 2 Grooves of the safety rings to mount the bayonet nut

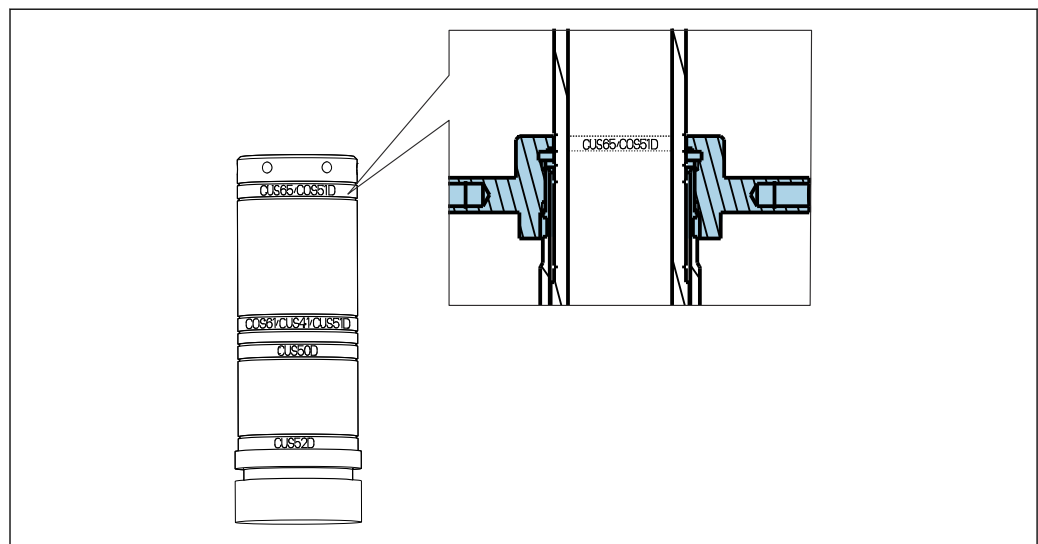

A0038479

**3** Mounting position of bayonet nut for CUS65D or COS51D

**i** The name indicated on the holder serves as a mounting aid. The bayonet nut covers over the marking for the selected sensor position.

## Measuring system

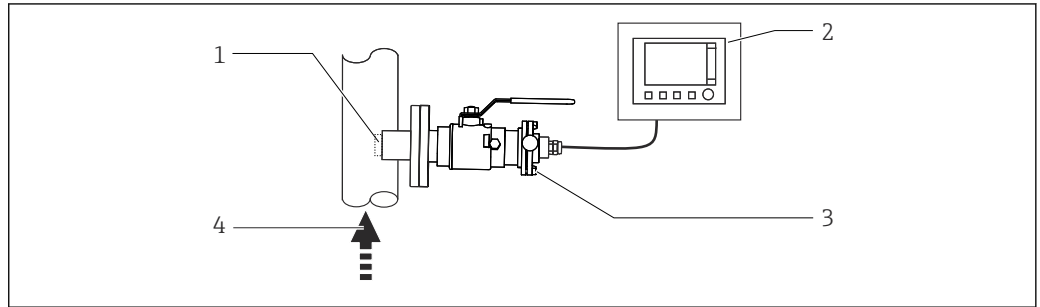

A0038660

### 4 Orientations, schematic

- 1 Sensor (see Accessories)
- 2 Transmitter
- 3 Retractable assembly
- 4 Direction of flow

**i** The orientation depends on the sensor head. Pay attention to the Operating Instructions for the relevant sensor. An inclination of at least 15° is recommended for amperometric sensors

- Make sure to avoid a siphon effect at the rinse chamber outlet. The inflow to the rinse chamber is always from below.

## Installation

### Orientation

The following diagram shows different installation positions in pipes, and indicates whether they are permitted or not.

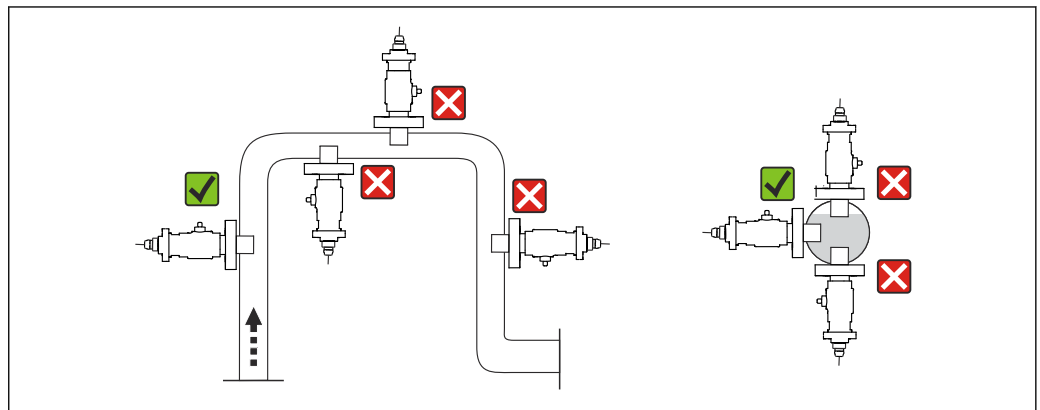

A0038661

### 5 Schematic of installation positions and orientations

- Ideally, the assembly should be mounted in an ascending pipe. Installation in a horizontal pipe is also possible.
- When using reflective materials (e.g. stainless steel), the pipe diameter must be at least 100 mm (4"). An onsite calibration is recommended.
- Install the sensor in places with uniform flow conditions.
- Do not install the sensor in places where air may collect or foam bubbles form or where suspended particles may settle.
- Avoid installation in the down pipe.
- Avoid fittings downstream from pressure reduction stages which can lead to outgassing.

**Installation instructions**

- ▶ Install the assembly in places with uniform flow conditions. The minimum pipe diameter is DN 80.



The installation instructions depend on the sensor used.

Detailed installation instructions are provided in both the Technical Information and in the Operating Instructions for the particular sensor.

## Environment

**Ambient temperature**

0 to 50 °C (32 to 122 °F)

## Process

**Medium temperature**

0 to 85 °C (32 to 185 °F)

**Medium pressure**

Max. 10 bar (145 psi)

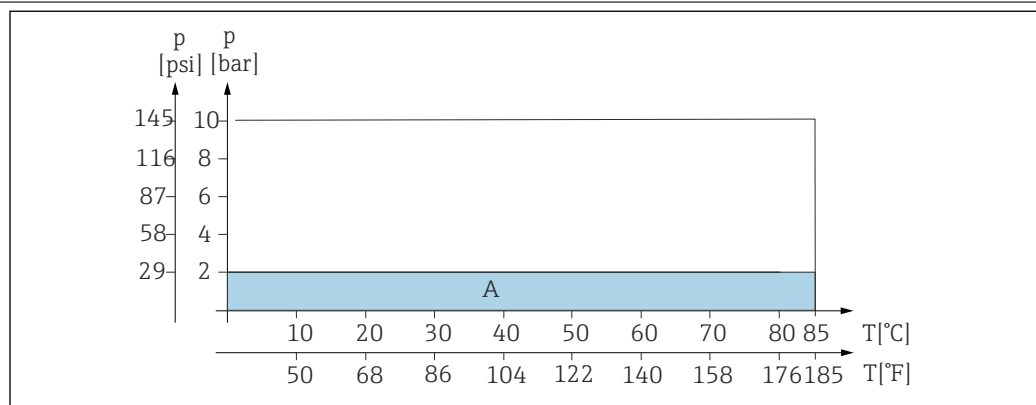

For manual insertion/retraction of the assembly, the medium pressure must not exceed 2 bar (29 psi)! Also take the process conditions of the sensor used into consideration!

**Pressure/temperature ratings**

A0038761

6 Pressure/temperature ratings

A Range in which the assembly can be operated manually

## Mechanical construction

### Dimensions

### Assembly with G2 thread and weld-in adapter in measuring position (long and short stroke)

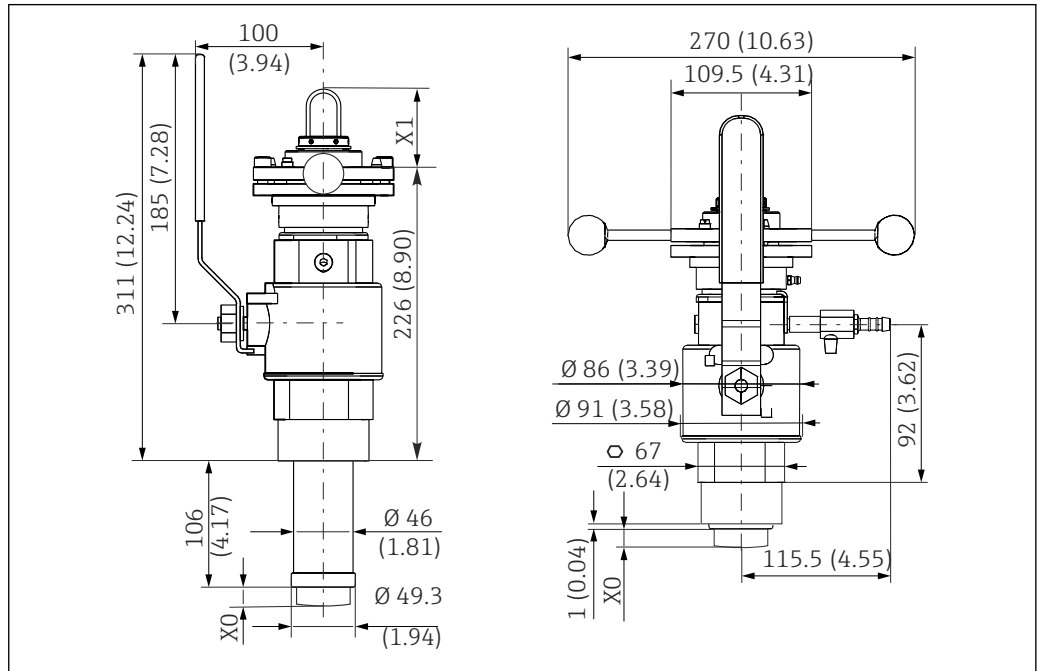

A0038481

7 Dimensions in mm (in)

X0, Dimensions depend on the sensor

X1,

X2

## Assembly with G2 thread and weld-in adapter in service position (long and short stroke)

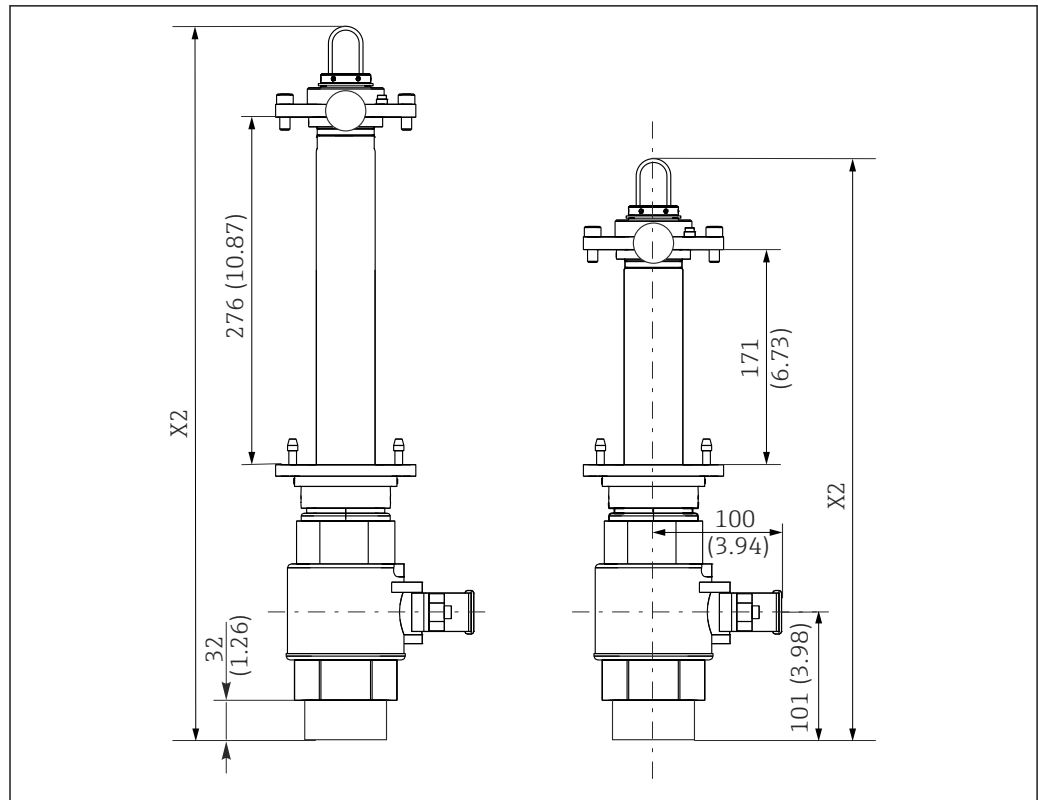

8 Dimensions in mm (in)

X2 Dimensions depend on the sensor



Assembly with flange connection

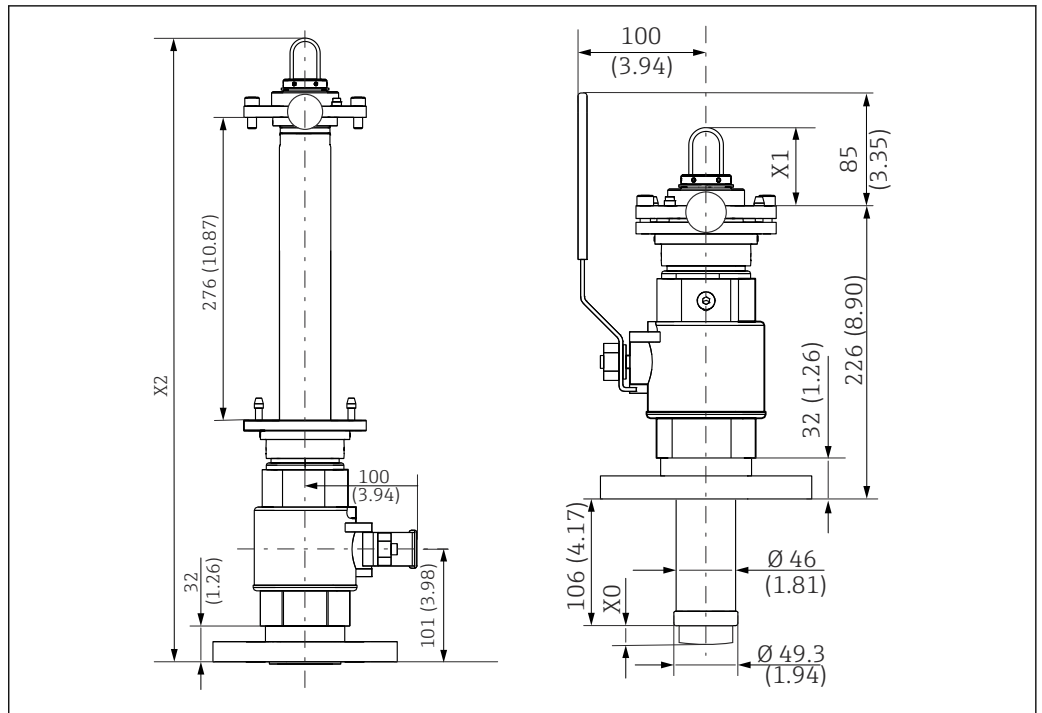

A0038651

9 Dimensions in mm (in)

X0, Dimensions depend on the sensor  
X2

Sensor	X0
CUS52D	25 (0.98)
CUS50D	26 (1)
CUS41/	16 (0.63)
CUS51D	5 (0.2)
COS61D	12 (0.47)
CUS65	21 (0.83)
COS51D	12 (0.47)

Sensor measuring position	X1
CUS52D	139 (5.47)
CUS50D	110 (4.33)
CUS41/CUS51D, COS61D	101 (3.98)
CUS65, COS51D	59 (2.32)

Sensor service position, long	X2
CUS52D	638 (25.12)
CUS50D	609 (23.98)

Sensor service position, long	X2
CUS41/CUS51D, COS61D	600 (23.62)
CUS65, COS51D	558 (21.97)

Sensor service position, short	X2
CUS52D	533 (20.98)
CUS50D	504 (19.84)
CUS41/CUS51D, COS61D	495 (19.49)
CUS65, COS51D	453 (17.83)

### Sensor holder with sensors

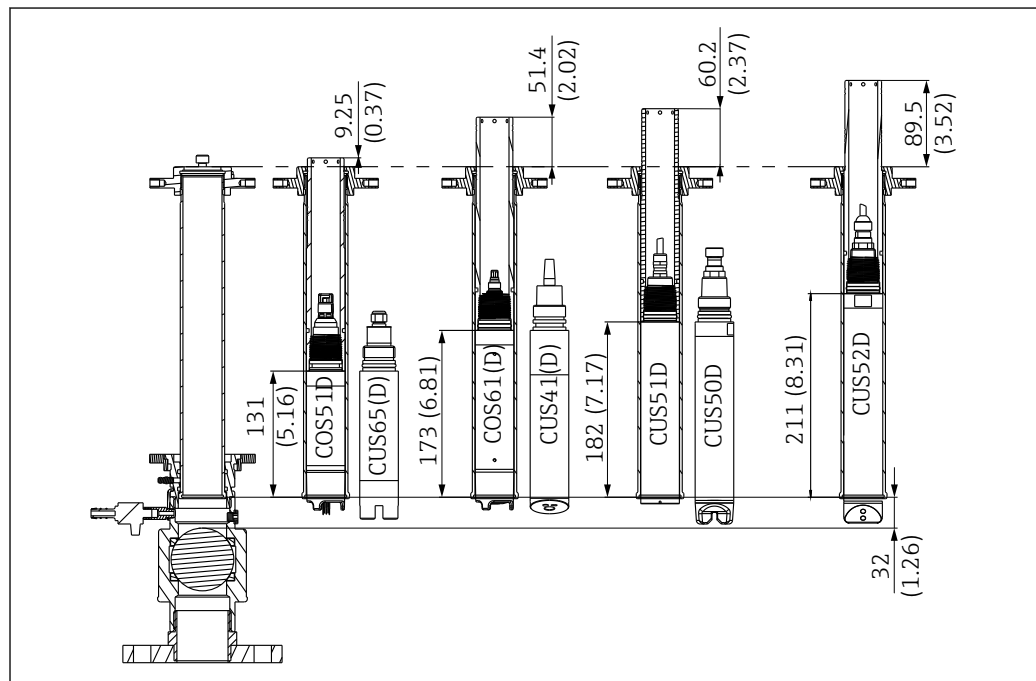

A0038478

10 Dimensions of sensor holder with sensors in mm (in)

## Process connections

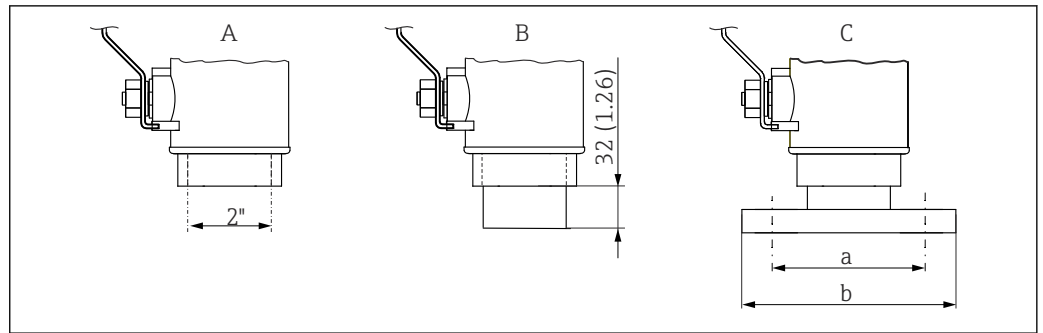

A0038650

11 Dimensions of process connections in mm (in)

A G2" female thread

B G2" female thread with weld-in adapter

C Flange DN 50 / PN 16 (as per EN 1092-1) and flange ANSI 2" / 150 lbs

a DN 50:  $\varnothing$  125 (4.92), ANSI 2":  $\varnothing$  120.7 (4.75)

b DN 50:  $\varnothing$  165 (6.50), ANSI 2":  $\varnothing$  152.4 (6.00)

## Rinse connection and vent cock

### Rinse connection nozzles

Connection options:

- 2 x ball valve with hose connection OD 9mm (see "Accessories"). (A ball valve is included in the delivery for the assembly. On its own it acts as a vent cock.)
- Customer's own rinse connections with G1/8 external thread
- 2 x G1/8 (internal)

### Vent cock

Ball valve with hose connection OD 9 mm

## Weight

Depending on version: 8 to 11 kg (17.6 to 24.3 lbs)

## Materials

Wetted:	Viton (seals)
	Stainless steel 1.4404 (AISI 316 L)
	Nickel-plated brass (vent cock or rinse connection)
Not wetted:	Stainless steel 1.4404 (AISI 316 L)

## Certificates and approvals

### CE/PED

The assembly has been manufactured according to good engineering practice as per Article 4, Paragraph 3 of the Pressure Equipment Directive 2014/68/EU and is therefore not required to bear the CE label.

## Ordering information

### Product page

[www.endress.com/CUA451](http://www.endress.com/CUA451)

### Product Configurator

On the product page there is a **Configure** button to the right of the product image.

1. Click this button.

↳ The Configurator opens in a separate window.

2. Select all the options to configure the device in line with your requirements.
    - ↳ In this way, you receive a valid and complete order code for the device.
  3. Export the order code as a PDF or Excel file. To do so, click the appropriate button on the right above the selection window.
-  For many products you also have the option of downloading CAD or 2D drawings of the selected product version. Click the **CAD** tab for this and select the desired file type using picklists.

---

**Scope of delivery**

The delivery comprises:

- Assembly in the version ordered
- Operating Instructions

## Accessories

The following are the most important accessories available at the time this documentation was issued.

- ▶ For accessories not listed here, please contact your Service or Sales Center.

### Device-specific accessories

#### Sensors

##### Turbimax CUS50D

- For nephelometric measurements of turbidity and solids in wastewater
- 4-beam scattered light method
- With Memosens technology
- Product Configurator on the product page: [www.endress.com/cus50d](http://www.endress.com/cus50d)



Technical Information TI00461C

##### Turbimax CUS51D

- For nephelometric measurements of turbidity and solids in wastewater
- 4-beam scattered light method
- With Memosens technology
- Product Configurator on the product page: [www.endress.com/cus51d](http://www.endress.com/cus51d)



Technical Information TI00461C

##### Turbimax CUS52D

- Hygienic Memosens sensor for turbidity measurement in drinking water, process water and in utilities
- With Memosens technology
- Product Configurator on the product page: [www.endress.com/cus52d](http://www.endress.com/cus52d)



Technical Information TI01136C

#### Welding socket

##### Welding socket

- Welding socket for pipe diameter from 80 mm, with combination flange DN 50 / ANSI 2":
  - Bores for DN 50 flange: 4 x 90° Ø18 on bolt circle Ø125 (4.92)
  - Bores for ANSI 2" flange: 4 x 90° Ø19 on bolt circle Ø121 (4.75)
- Flange seal, 4 screws M16x60, 4 M16 nuts including washers,
- Stainless steel 1.4571 (AISI 316 Ti)
- Order No. 50080249

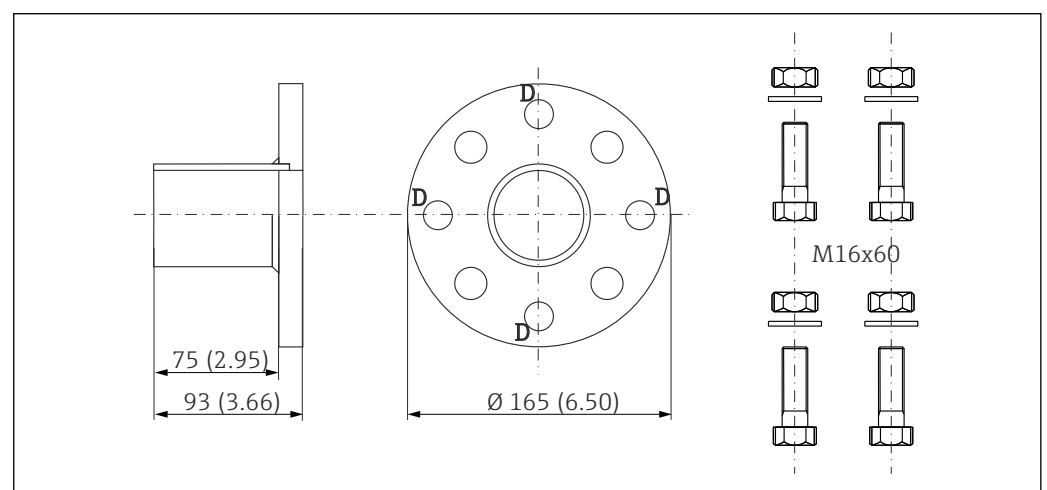

A0038764

12 Welding socket, dimensions in mm (in)

D Markings for bores, DN 50 flange

**Welding nipple**

- Welding nipple for 2" thread
- Stainless steel 1.4404 (AISI 316 L)
- Order No. 71448684

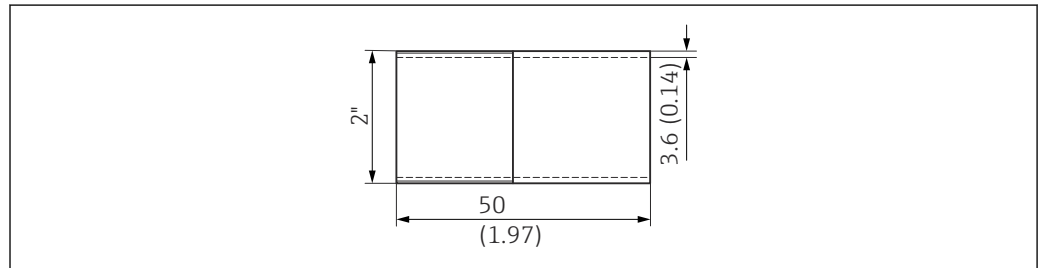

A0038763

13 Welding nipple, dimensions in mm (in)

**Welding rinse socket DN 65**

- For automatic spray cleaning of CUS51D/31/41 sensors in pipes and vessels:
  - Bores for DN 50 flange: 4 x 90° Ø18 on bolt circle Ø125
  - Bores for ANSI 2" flange: 4 x 90° Ø19 on bolt circle Ø121
- Rinse connection: male thread R $\frac{1}{4}$
- With removable rinse nozzle
- Up to 6 bar (87 psi), 80 °C (176 °F)
- Order No. 51500912

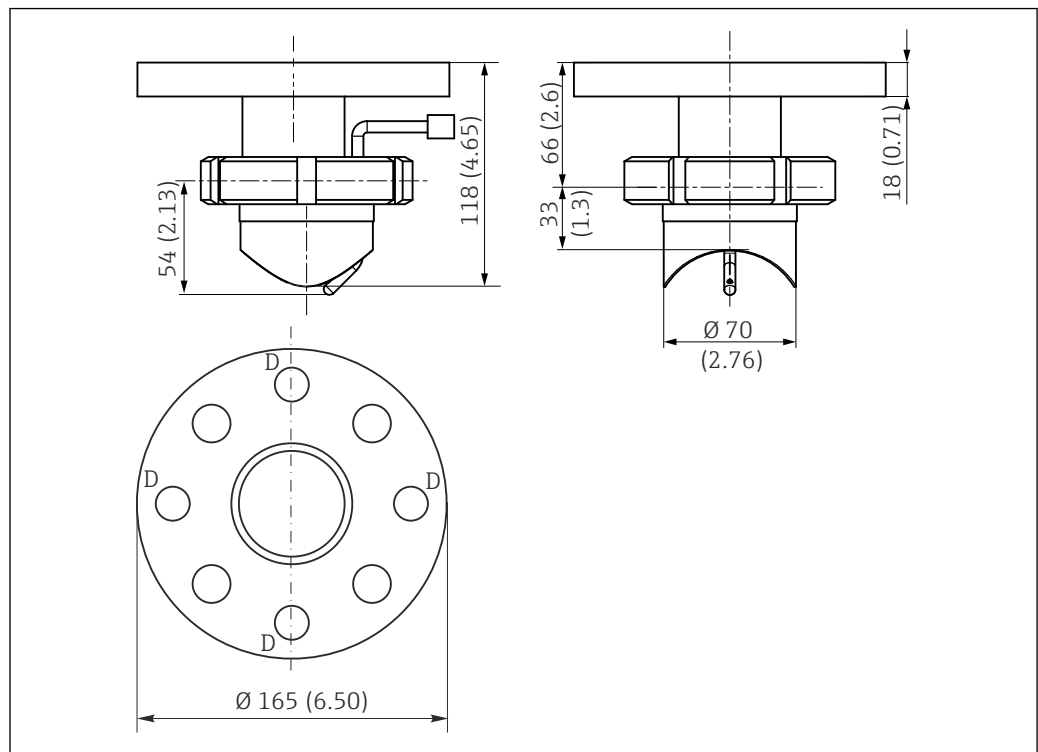

A0038762

14 Welding rinse socket, dimensions in mm (in)

D Markings for bores, DN 50 flange

**Service-specific accessories****Ball valve for rinse chamber**

- As rinse connection complementing or replacing the vent cock supplied;
- Order No. 51512982

**O-ring set**

- Viton + FPM
- Order No. 51512981





[www.addresses.endress.com](http://www.addresses.endress.com)

---