

# Brief Operating Instructions

## Liquitrend QMW43

Conductive and capacitive measurement of conductivity and thickness of buildup

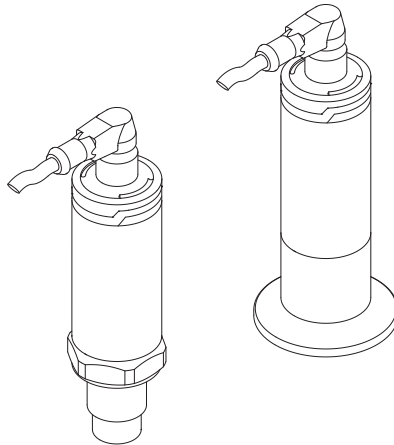

These Instructions are Brief Operating Instructions; they are not a substitute for the Operating Instructions pertaining to the device.

Detailed information about the device can be found in the Operating Instructions and the other documentation:

Available for all device versions via:

- Internet: [www.endress.com/deviceviewer](http://www.endress.com/deviceviewer)
- Smart phone/tablet: *Endress+Hauser Operations App*

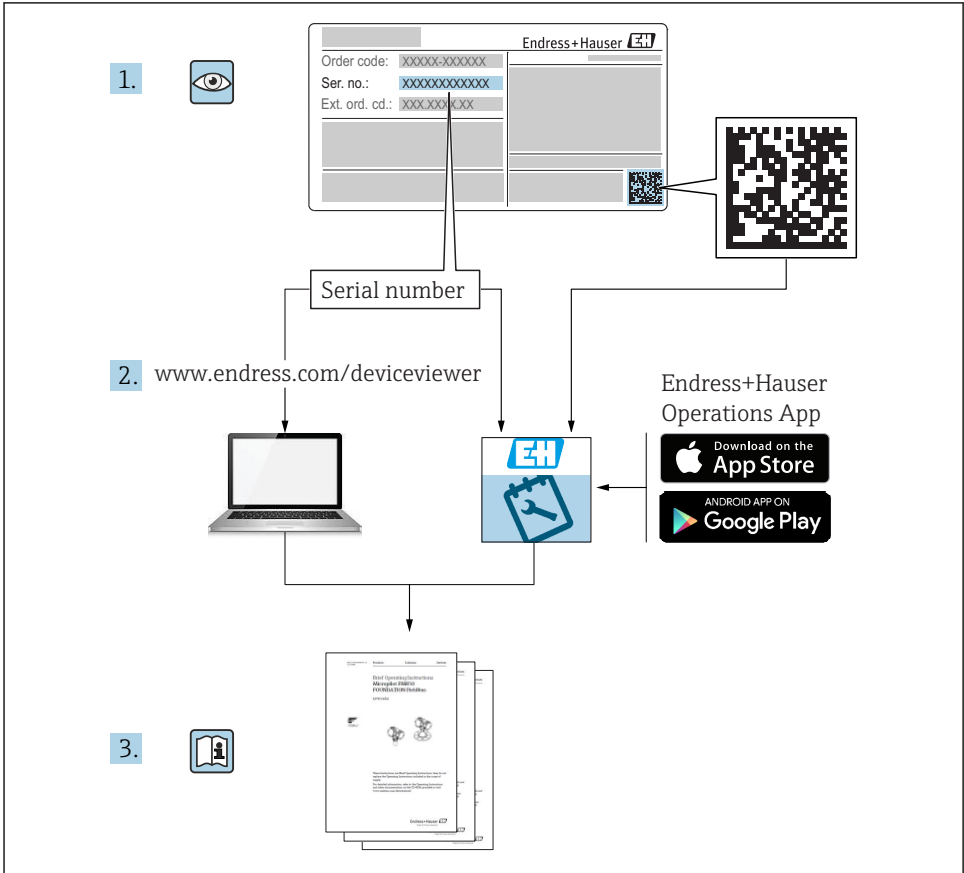

A0023555

# Table of contents

<b>1</b>	<b>About this document</b>	<b>4</b>
1.1	Symbols	4
1.2	Terms and abbreviations	5
1.3	Documentation	6
1.4	Registered trademarks	6
<b>2</b>	<b>Basic safety instructions</b>	<b>6</b>
2.1	Requirements for the personnel	6
2.2	Designated use	6
2.3	Workplace safety	7
2.4	Operational safety	7
2.5	Product safety	7
2.6	IT security	8
<b>3</b>	<b>Product description</b>	<b>8</b>
3.1	Product design	8
<b>4</b>	<b>Incoming acceptance and product identification</b>	<b>9</b>
4.1	Incoming acceptance	9
4.2	Product identification	9
4.3	Manufacturer address	9
4.4	Nameplate	10
4.5	Storage, transport	11
<b>5</b>	<b>Installation</b>	<b>11</b>
5.1	Installation conditions	11
5.2	Mounting the measuring device	13
5.3	Post-installation check	13
<b>6</b>	<b>Electrical connection</b>	<b>14</b>
6.1	Connecting the device	14
6.2	Post-connection check	14
<b>7</b>	<b>Operation options</b>	<b>15</b>
7.1	IO-Link information	15
7.2	IO-Link download	15
7.3	Structure of the operating menu	15
<b>8</b>	<b>System integration</b>	<b>15</b>
<b>9</b>	<b>Commissioning</b>	<b>16</b>
9.1	Function check	16
9.2	Light signals (LEDs)	16
9.3	Changing device parameters via IO-Link	16
<b>10</b>	<b>Operation</b>	<b>17</b>
<b>11</b>	<b>Diagnostics and troubleshooting</b>	<b>17</b>
11.1	General troubleshooting	17
11.2	Diagnostic information via light emitting diodes	18
<b>12</b>	<b>Description of Device Parameters</b>	<b>18</b>

# 1 About this document

## 1.1 Symbols

### 1.1.1 Safety symbols

#### CAUTION

This symbol alerts you to a dangerous situation. Failure to avoid this situation can result in minor or medium injury.

#### DANGER

This symbol alerts you to a dangerous situation. Failure to avoid this situation will result in serious or fatal injury.

#### NOTICE

This symbol contains information on procedures and other facts which do not result in personal injury.

#### WARNING

This symbol alerts you to a dangerous situation. Failure to avoid this situation can result in serious or fatal injury.

### 1.1.2 Tool symbols



Open-ended wrench

### 1.1.3 Symbols for certain types of information and graphics

#### Permitted

Procedures, processes or actions that are permitted.



#### Preferred

Procedures, processes or actions that are preferred

#### Forbidden

Procedures, processes or actions that are forbidden.



#### Tip

Indicates additional information



Notice or individual step to be observed

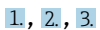

Series of steps



Result of a step

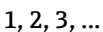

Item numbers

**A, B, C, ...**

Views

**Safety instructions**

Observe the safety instructions contained in the associated Operating Instructions

**Connecting cable immunity to temperature change**

Specifies the minimum value of the temperature resistance of the connection cables

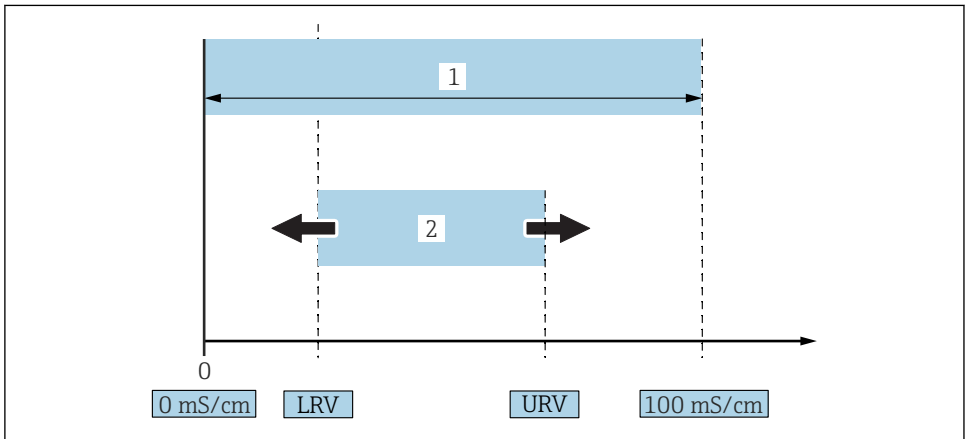
**1.2 Terms and abbreviations**

A0041153

 1 *Measuring range, span (conductivity)*

1 *Maximum conductivity measuring range*

2 *Adjusted span*

**Maximum conductivity measuring range**

Span between 0 to 100 for editable range.

**Adjusted span**

Span between LRV (Lower Range Value) and URV (Upper Range Value)

The difference between the LRV and URV must be at least 1 mS/cm.

Factory setting: 0 to 100 mS/cm

Other configured spans can be ordered as customized spans.

**Other abbreviations**

UHT: Ultra-High Temperature

CIP: Cleaning in Place

## 1.3 Documentation



For an overview of the scope of the associated Technical Documentation, refer to the following:

- *W@M Device Viewer* ([www.endress.com/deviceviewer](http://www.endress.com/deviceviewer)): Enter the serial number from nameplate
- *Endress+Hauser Operations App*: Enter the serial number from the nameplate or scan the 2D matrix code (QR code) on the nameplate

### 1.3.1 Brief Operating Instructions (KA)

#### Guide that takes you quickly to the 1st measured value

The Brief Operating Instructions contain all the essential information from incoming acceptance to initial commissioning.

## 1.4 Registered trademarks

### IO-Link

is a registered trademark of the IO-Link company group.

# 2 Basic safety instructions

## 2.1 Requirements for the personnel

The personnel must fulfill the following requirements to carry out the necessary tasks, e. g., commissioning and maintenance:

- ▶ Trained, qualified specialists must have a relevant qualification for the specific function and task
- ▶ Are authorized by the plant owner/operator
- ▶ Are familiar with federal/national regulations
- ▶ Must have read and understood the instructions in the manual and supplementary documentation
- ▶ Follow instructions and comply with conditions

## 2.2 Designated use

Improper use can pose hazards

- ▶ Ensure that the measuring device is free of defects while it is in operation
- ▶ Use the measuring device only for media to which the process-wetted materials have an adequate level of resistance
- ▶ Do not overshoot or undershoot the relevant limit values of the measuring device



For detailed information, please refer to the relevant Technical Information and Operating Instructions.

### 2.2.1 Incorrect use

The manufacturer is not liable for damage caused by improper or non-designated use.

Clarification of borderline cases:

- ▶ For special materials and media used for cleaning, the manufacturer is happy to provide assistance in verifying the corrosion resistance of medium-wetted materials, but disclaims any warranty or liability.

### **Residual risks**

Due to heat transfer from the process, the temperature of the electronics housing and the assemblies contained therein may rise to 80 °C (176 °F) during operation.

Danger of burns from contact with surfaces!

- ▶ If necessary, ensure protection against contact to prevent burns.

## **2.3 Workplace safety**

When working on and with the device:

- ▶ Wear the required personal protective equipment according to federal/national regulations.

For welding work on the piping:

- ▶ Do not ground the welding unit via the device.

If working on and with the device with wet hands:

- ▶ Due to the increased risk of electric shock, gloves must be worn.

## **2.4 Operational safety**

Risk of injury!

- ▶ Operate the device only if it is in proper technical condition, free from errors and faults.
- ▶ The operator is responsible for ensuring failure-free operation of the device.

### **Modifications to the device**

Unauthorized modifications to the device are not permitted and can lead to unforeseeable dangers.

- ▶ If, despite this, modifications are required, consult with Endress+Hauser.

### **Repair**

Repairs are not envisaged for this device.

## **2.5 Product safety**

This measuring device is designed in accordance with good engineering practice to meet state-of-the-art safety requirements, has been tested, and left the factory in a condition in which it is safe to operate.

It meets general safety standards and legal requirements. It also complies with the EC directives listed in the device-specific EC Declaration of Conformity. Endress+Hauser confirms this by affixing the CE mark to the device.

## 2.6 IT security

We only provide a warranty if the device is installed and used as described in the Operating Instructions. The device has safety mechanisms integrated to prevent users from inadvertently changing settings.

Provide additional protection for the device and data transfer to/from the device

- ▶ IT security measures defined in the plant owner/operator's own security policy must be implemented by plant owners/operators themselves.

## 3 Product description

- Compact measuring device
- Continuous measurement of conductive and capacitive components of media for the measurement of buildup thickness and conductivity

Flush-mounting of the device in pipes or in storage, mixing and process vessels enables the optimization of CIP cleaning, UHT applications as well as process cycle times.

### 3.1 Product design

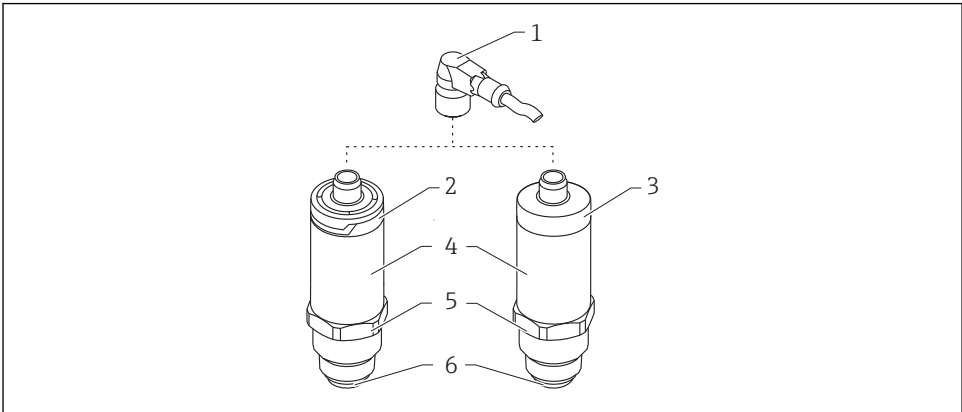

A0036957

#### 2 Product design

- 1 M12 plug
- 2 Plastic housing cover IP65/67
- 3 Metal housing cover IP66/68/69
- 4 Housing
- 5 Process connection
- 6 Sensor



## 4 Incoming acceptance and product identification

### 4.1 Incoming acceptance

Check the following during incoming acceptance:

- Are the order codes on the delivery note and the product sticker identical?
  - Are the goods undamaged?
  - Do the nameplate data match the ordering information on the delivery note?
  - If required (see nameplate): Are the safety instructions (XA) provided?
-  If one of these conditions is not met, please contact the manufacturer's sales office.

### 4.2 Product identification

The following options are available for the identification of the measuring device:

- Nameplate specifications
  - Serial number
  - 2-D matrix code (QR code)
  - Extended order code with breakdown of the device features on the delivery note
- ▶ Enter the serial number from the nameplates in the *W@M Device Viewer* ([www.endress.com/deviceviewer](http://www.endress.com/deviceviewer))
- ↳ All the information about the measuring device and all associated Technical Documentation are displayed.
- ▶ Enter the serial number on the nameplate into the *Endress+Hauser Operations App* or use the *Endress+Hauser Operations App* to scan the 2-D matrix code (QR Code) on the nameplate
- ↳ All the information about the measuring device and all associated Technical Documentation are displayed.

### 4.3 Manufacturer address

Endress+Hauser SE+Co. KG  
Hauptstraße 1  
79689 Maulburg, Germany

Address of the manufacturing plant: See nameplate.

## 4.4 Nameplate

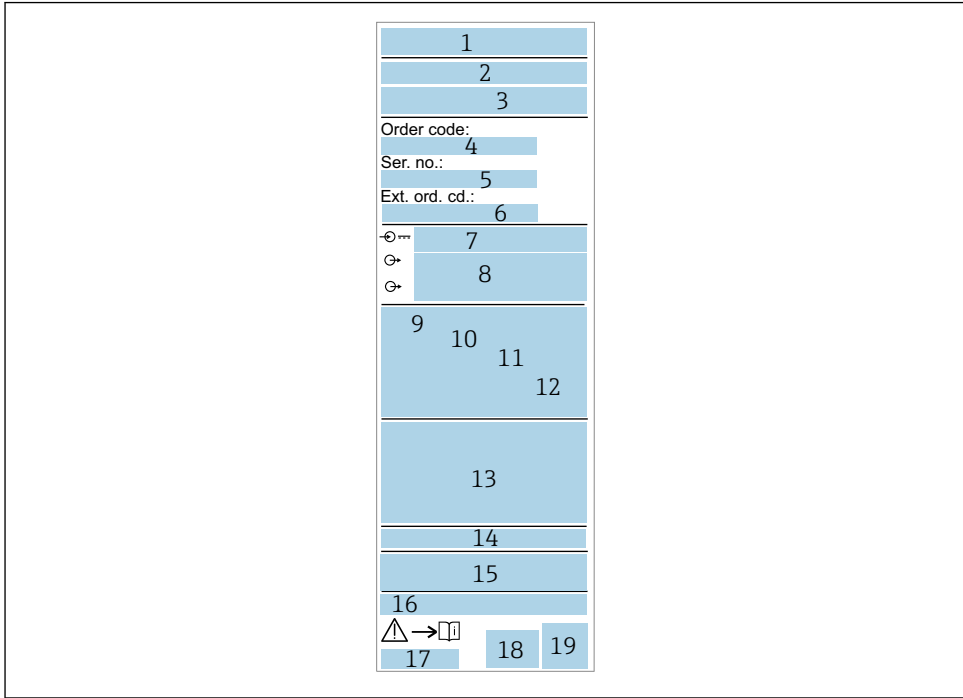

A0041309

- 1 *Manufacturer name/logo*
- 2 *Device name*
- 3 *Manufacturer's address*
- 4 *Order code*
- 5 *Serial number*
- 6 *Extended order code*
- 7 *Supply voltage*
- 8 *Signal output*
- 9 *Process temperature*
- 10 *Ambient temperature range*
- 11 *Process pressure*
- 12 *Firmware*
- 13 *Certificate symbols, communication mode (optional)*
- 14 *Degree of protection, e. g. IP, NEMA*
- 15 *Approval-specific information*
- 16 *Measuring point identification (optional)*
- 17 *Document number of Operating Instructions*
- 18 *Manufacturing date: year-month*
- 19 *2-D matrix code (QR code)*

## 4.5 Storage, transport

### 4.5.1 Storage conditions

- Permitted storage temperature:  $-40$  to  $+85$  °C ( $-40$  to  $+185$  °F)
- Use original packaging.

### 4.5.2 Transporting the product to the measuring point

Transport the device to the measuring point in the original packaging.

## 5 Installation

### 5.1 Installation conditions

#### 5.1.1 Mounting location

Installation in vessel, pipe or tank.

#### 5.1.2 Vessel or tank

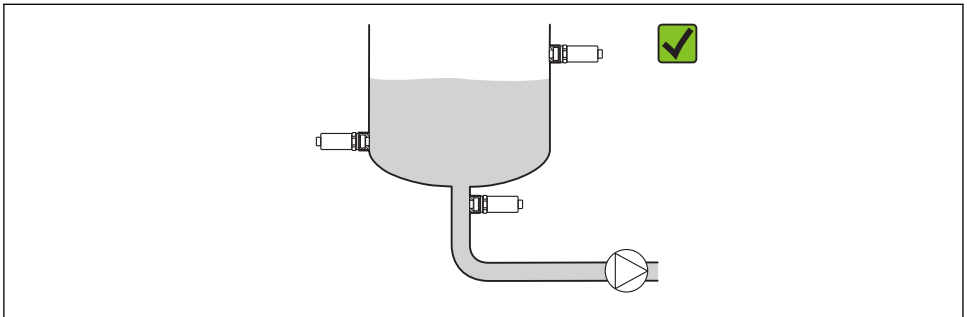

A0040922

3 Installation examples

### 5.1.3 Pipes

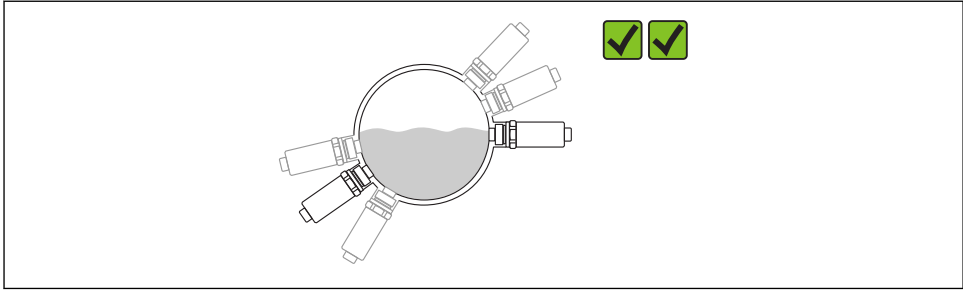

A0021052

4 Horizontal orientation → preferred orientation

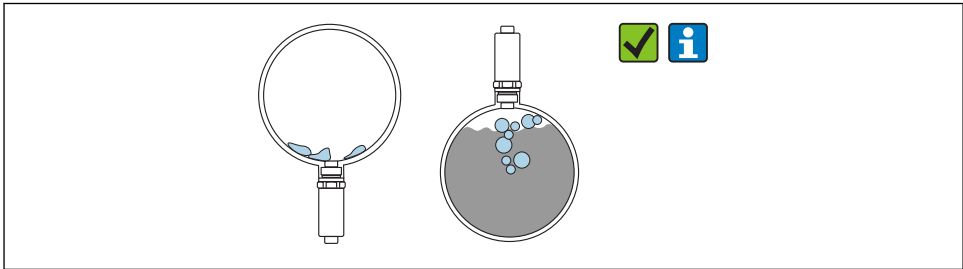

A0038773

5 Vertical orientation → formation of buildup or bubbles on the sensor must be taken into account

**i** The possibility of buildup or bubbles forming on the sensor when installed vertically must be taken into account. If the sensor is partially covered, or if encrustations or air bubbles have formed on the sensor, this will be reflected in the measured value.

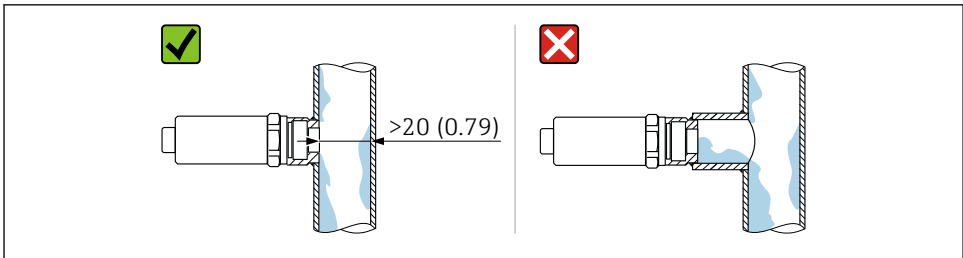

A0041584

6 Flush-mounted orientation. Unit of measurement mm (in)

### 5.1.4 Special mounting instructions

- When installing the plug, do not allow moisture to enter the plug or socket area
- Protect housing against impact

## 5.2 Mounting the measuring device

### 5.2.1 Required tools

- Open-ended wrench
- Hexagon socket wrench for measuring points that are difficult to access

When screwing into place, turn by the hex bolt only 32 mm.

Torque: 15 to 30 Nm (11 to 22 lbf ft)

### 5.2.2 Installation instructions

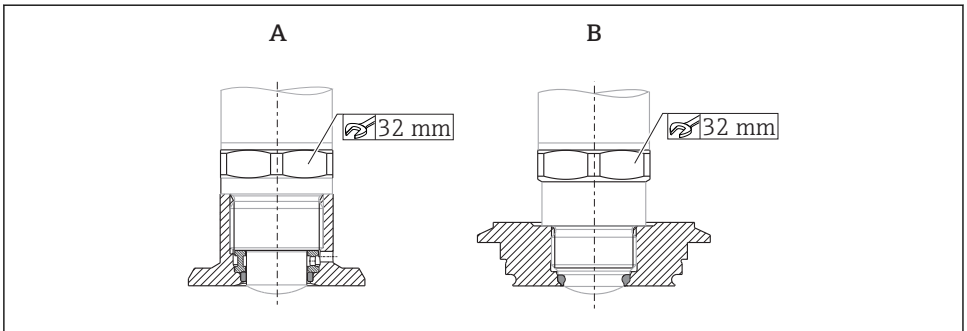

A0037386

#### 7 Installation examples

A Thread G 3/4", G 1"

B Thread M24x1.5

## 5.3 Post-installation check

- Is the device undamaged (visual inspection)?
- Does the device comply with the measuring point specifications?
  - Process temperature
  - Process pressure
  - Ambient temperature range
  - Measuring range
- Are the measuring point identification and labeling correct (visual inspection)?
- Is the device adequately protected against precipitation and direct sunlight?
- Is the device adequately protected against impact?
- Are all mounting and safety screws securely tightened?
- Is the device properly secured?

## 6 Electrical connection

### 6.1 Connecting the device

#### ⚠ WARNING

**Risk of injury from the uncontrolled activation of processes!**

- ▶ Switch off the supply voltage before connecting the device.
- ▶ Make sure that downstream processes are not started unintentionally.

#### ⚠ WARNING

**Electrical safety is compromised by an incorrect connection!**

- ▶ In accordance with IEC/EN61010 a suitable circuit breaker must be provided for the device .
- ▶ Voltage source: Non-hazardous contact voltage or Class 2 circuit (North America).
- ▶ The device must be operated with a fine-wire fuse 500 mA (slow-blow).

Protective circuits against reverse polarity are integrated.

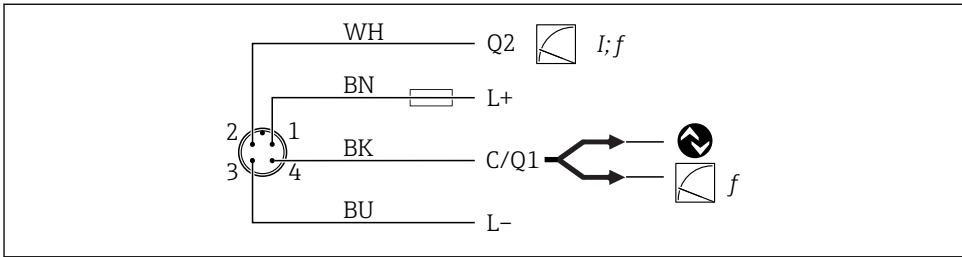

A0041101

#### 🔌 8 Connection

Pin 1 Supply voltage +

Pin 2 Current output 4 to 20 mA or frequency 300 to 3 000 Hz

Pin 3 Supply voltage -

Pin 4 IO-Link communication or frequency 300 to 3 000 Hz

### 6.2 Post-connection check

- Are the device and cable undamaged (visual inspection)?
- Does the supply voltage match the specifications on the nameplate?
- If supply voltage is present, is the green LED lit?
- With IO-Link communication: is the green LED flashing?

## 7 Operation options

### 7.1 IO-Link information

IO-Link is a point-to-point connection for communication between the device and an IO-Link master. This requires an IO-Link compatible module (IO-Link master) for operation. The IO-Link communication interface enables direct access to the process and diagnostic data. It also provides the option of configuring the device during operation.

The device supports the following characteristics of the physical layer:

- IO-Link specification: version 1.1
- IO-Link Smart Sensor Profile 2nd Edition
- SIO mode: Yes
- Speed: COM2; 38.4 kBaud
- Minimum cycle time: 6 ms
- Process data width: 32 bit
- IO-Link data storage: Yes
- Block configuration: Yes



Regardless of the customer-specific default settings selected, the device always has the option of communicating or being configured via IO-Link.

### 7.2 IO-Link download

<http://www.endress.com/download>

- Select "Device Driver" from the list displayed
- In the Type search field, select "IO Device Description (IODD)"
- In the Product Code search field, select the product root
- Click "Search" button → Select result → Download

Optional: In the Text Search search field, enter the device name.

### 7.3 Structure of the operating menu



For detailed information, please refer to the relevant Operating Instructions.

## 8 System integration



For detailed information, please refer to the relevant Operating Instructions.

## 9 Commissioning

### 9.1 Function check

Prior to commissioning, make sure that the post-installation and post-connection checks have been performed.

Checklists in sections

- Post-installation check
- Post-connection check

### 9.2 Light signals (LEDs)

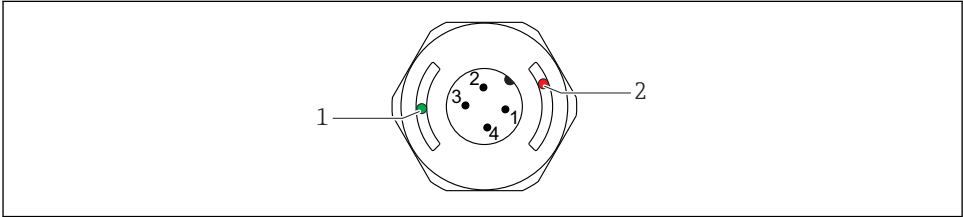



A0041157

#### 9 Position of LEDs in housing cover

- 1 green (GN), status, communication
- 2 red (RD), warning or fault

Description of the function of the LEDs

#### Position 1: green (GN) status, communication

- Lit: no communication
- Flashing: active communication, flash frequency 
- Flashing with increased luminosity: device search (device identification), flash frequency 

#### Position 2: red (RD) warning or fault

- Warning/maintenance required:  
Flashing: error is remediable, e. g. invalid adjustment
- Fault/device failure:  
Lit: see diagnostics and troubleshooting

 There is no external signaling via LEDs on the metal housing cover (IP69).

### 9.3 Changing device parameters via IO-Link

#### Block configuration:

All changed parameters become active only after download.

#### Direct configuration:

A single changed parameter becomes active immediately after input.



Confirm each change with Enter to ensure that the value is accepted.

### **WARNING**

**Risk of injury and damage to property due to uncontrolled activation of processes!**

- ▶ Make sure that downstream processes are not started unintentionally.

**Commissioning with customer-specific default settings:**

The device can be put into operation without any additional configuration.

**Commissioning with factory settings:**

If an application-specific setting is required, the span and the output assignment can be adjusted via the IO-Link interface.

## 10 Operation



For detailed information with a sample application involving buildup measurement in pipes or tanks, see the relevant Operating Instructions.

## 11 Diagnostics and troubleshooting



For detailed information, please refer to the relevant Operating Instructions.

### 11.1 General troubleshooting

**Device does not respond**

Supply voltage does not match the value indicated on the nameplate.

- ▶ Apply correct voltage.

The polarity of the supply voltage is wrong.

- ▶ Correct the polarity.

Connecting cables are not in contact with the terminals.

- ▶ Check for electrical contact between cables and correct.

**No communication**

Connecting cable is defective, incorrectly connected or is not making contact.

- ▶ Check wiring and cables.

There is an error in the device, which is preventing communication.

- ▶ Replace device.

**No transmission of process data**

Internal sensor error or electronics error.

- ▶ Correct all errors that are displayed as a diagnostic event .

## 11.2 Diagnostic information via light emitting diodes

### Green LED not lit

No supply voltage.

- ▶ Check connector, cable and supply voltage.

### LED not flashing

No communication.

- ▶ Check connector, cable, supply voltage and IO-Link master.

### LED flashing red

Overload or short-circuit in load circuit.

- ▶ Clear the short-circuit.

Ambient temperature outside of specification.

- ▶ Operate measuring device in specified temperature range.

### Red LED continuously lit

Internal sensor error.

- ▶ Replace device.



There is no external signaling via LEDs on the metal housing cover (IP69).

## 12 Description of Device Parameters



For detailed information, please refer to the relevant Operating Instructions.





71461733

[www.addresses.endress.com](http://www.addresses.endress.com)

---