

Technical Information

TLSW1 Thermowell

Fabricated thermowell with threaded process and thermometer connections



Application

Thermowells serve as protective devices for the primary detecting elements, e.g. RTD's and thermocouples for temperature control, recording and indicating of various processes.

Material

The thermowell is fabricated from SS316/L material as standard. Other materials are available upon request. Generally the thermowell material chosen for a specific installation is governed by corrosion conditions to which the thermowell is exposed. In some instances, strength is a primary requirement while corrosion resistance is secondary.

The model TLSW1 is a general purpose metal protection tube with threaded process and thermometer connection adaptor welded on.

Immersion length and accuracy factor

The distance from the hot end of the thermowell to the underside of the thread, or other connection, is identified as the immersion length U. For accuracy, the immersion length should be long enough to permit the entire temperature sensitive portion of the thermometer bulb, or the thermocouple element, to project into the temperature medium to be measured.

Thermocouples have a short sensitive portion and can be used with thermowells having short immersion lengths.

Resistance (RTD) thermometers have sensitive portions between 25 and 50 mm long.

Mechanical construction

Design, dimensions

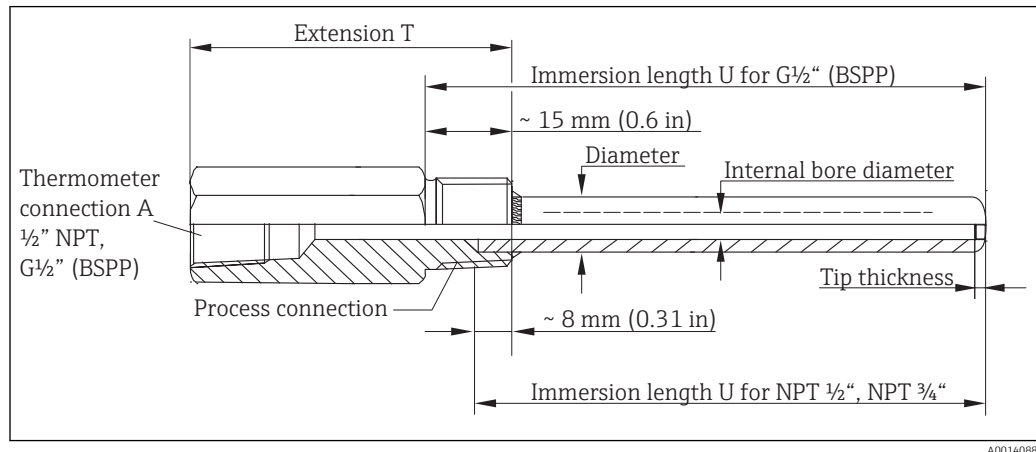

1 Design of the thermowell with process connection options NPT 1/2", NPT 3/4" or G1/2" (BSPP)

Weight

Typical values, around 0.2 to 1 kg (0.44 to 2.2 lb) depending on the version and standard length.

Performance characteristics

Operating conditions

Maximum process pressure

Diameter	Pressure
10 mm (0.4 in)	<ul style="list-style-type: none"> ■ 5 MPa (50 bar) at 20 °C (68 °F) ■ 3.3 MPa (33 bar) at 250 °C (482 °F) ■ 2.4 MPa (24 bar) at 400 °C (752 °F)
12 mm (0.47 in)	<ul style="list-style-type: none"> ■ 7.5 MPa (75 bar) at 20 °C (68 °F) ■ 5 MPa (50 bar) at 250 °C (482 °F) ■ 3.5 MPa (35 bar) at 400 °C (752 °F)
1/4" NB sch. 40	<ul style="list-style-type: none"> ■ 7.5 MPa (75 bar) at 20 °C (68 °F) ■ 5 MPa (50 bar) at 250 °C (482 °F) ■ 3.5 MPa (35 bar) at 400 °C (752 °F)
1/2" NB sch. 40	<ul style="list-style-type: none"> ■ 10 MPa (100 bar) at 20 °C (68 °F) ■ 6.7 MPa (67 bar) at 250 °C (482 °F) ■ 4.6 MPa (46 bar) at 400 °C (752 °F)

Maximum process temperature

Up to +600 °C (+1 112 °F)

Maximum flow velocity

The maximum process fluid velocity supported by the thermowell decreases as the exposed immersion length increases.



If required, contact the sales office or your sales representative to request a full thermowell stress calculation for this thermowell under the operating conditions that you specify. Please provide the following information:

- Process medium: fluid or density
- Process temperature
- Process pressure
- Dimension of the thermowell
- Flow velocity

Installation

This thermowell can be installed on pipes or on tanks by means of NPT 1/2", NPT 3/4" or G1/2" (BSPP) threaded connections. During installation, it is necessary to correctly determine the immersion length, because an incorrect evaluation could affect the accuracy of the sensor. For this reason, the immersion length must be at least 80 mm (3.15 in) 80 mm (3.15 in). In the case of installation in pipes with a reduced diameter, the axis line of the duct should be reached and if possible it should be slightly exceeded from tip of the thermowell (see figure below).

Installation of the thermowell inclined and with its sensitive part facing the direction of the process flow, may be a valid alternative to the most commonly used perpendicular one. Special attention should be paid in the case of installation in processes with two-phase flows, since they may cause fluctuations in the detected temperature values.

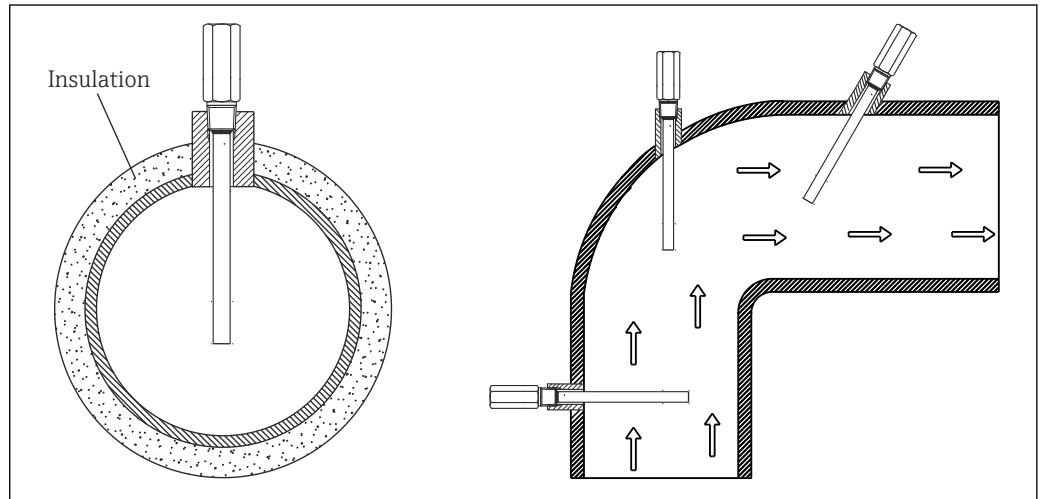

2 Installation on pipes and installation options

A0019001-EN

Certificates and approvals

Material certification

The material certificate 3.1 (according to EN 10204) can be selected directly in the product configuration. Other types of certificates related to materials can be requested separately.

Test on thermowell

Thermowell hydrostatic pressure test applied internally and dye penetrant tests on welding can be directly selected in the product configuration, if required.

PER (pressure equipment regulation)

The assembly has no pressurised volumes and thus is not subject to the conformity assessment requirements of the PER when operating within the published product specifications.

Reasons: The definitions of pressure-bearing equipment as per sections 4.1.1 and 4.3.2 of the directive SANS 347:2012 determine that:

- The products are classified as pressure accessories and are designed and manufactured in accordance with sound engineering practice (SEP) in order to ensure safe use.
- This declaration does not apply if the product is used as a critical component in a safety system. In this case, the product must be assessed in line with the same category or higher than the equipment they protect (section 4.3.3).

Ordering information

Detailed ordering information is available from the following sources:

- In the Product Configurator on the Endress+Hauser website: www.endress.com -> Click "Corporate" -> Select your country -> Click "Products" -> Select the product using the filters and search field -> Open product page -> The "Configure" button to the right of the product image opens the Product Configurator.
- From your Endress+Hauser Sales Center: www.addresses.endress.com



Product Configurator - the tool for individual product configuration

- Up-to-the-minute configuration data
- Depending on the device: Direct input of measuring point-specific information such as measuring range or operating language
- Automatic verification of exclusion criteria
- Automatic creation of the order code and its breakdown in PDF or Excel output format
- Ability to order directly in the Endress+Hauser Online Shop

www.addresses.endress.com
