

# Technical Information

## Proline Promass 80E, 83E

### Coriolis flowmeter



The flowmeter for minimized cost of ownership with extended transmitter functionality (Promass 83)

#### Application

- Measuring principle operates independently of physical fluid properties such as viscosity or density
- Highly accurate measurement of liquids and gases for a wide range of standard applications

#### Device properties

- Compact dual-tube system
- Medium temperature up to +140 °C (+284 °F)
- Process pressure: up to 100 bar (1450 psi)
- Device in compact or remote version

#### Promass 83

- 4-line backlit display with touch control
- HART, PROFIBUS PA/DP, Modbus RS485, FF, EtherNet/IP

#### Your benefits

- Cost-effective – multi-purpose device; an alternative to conventional volumetric flowmeters
- Fewer process measuring points – multivariable measurement (flow, density, temperature)
- Space-saving installation – no in/outlet run needs

#### Promass 83

- Quality – software for filling & dosing, density & concentration, advanced diagnostics
- Flexible data transfer options – numerous communication types
- Automatic recovery of data for servicing

## Table of contents

<b>Function and system design</b> .....	<b>3</b>	Medium pressure range (nominal pressure) .....	19
Measuring principle .....	3	Pressure-temperature ratings .....	20
Measuring system .....	4	Rupture disk .....	23
<b>Input</b> .....	<b>5</b>	Limiting flow .....	23
Measured variable .....	5	Pressure loss .....	23
Measuring range .....	5	System pressure .....	24
Operable flow range .....	5	Thermal insulation .....	24
Input signal .....	6	Heating .....	24
<b>Output</b> .....	<b>6</b>	<b>Mechanical construction</b> .....	<b>25</b>
Output signal .....	6	Design, dimensions .....	25
Signal on alarm .....	8	Weight .....	44
Load .....	8	Materials .....	44
Low flow cutoff .....	8	Process connections .....	45
Galvanic isolation .....	8	<b>Operability</b> .....	<b>45</b>
Switching output .....	9	Local operation .....	45
<b>Power supply</b> .....	<b>9</b>	Language group .....	45
Terminal assignment .....	9	Remote operation .....	45
Supply voltage .....	10	<b>Certificates and approvals</b> .....	<b>46</b>
Power consumption .....	10	CE mark .....	46
Power supply failure .....	10	C-Tick symbol .....	46
Electrical connection .....	11	Ex approval .....	46
Electrical connection remote version .....	12	Hygienic compatibility .....	46
Potential equalization .....	12	Functional safety .....	46
Cable entries .....	12	HART certification .....	46
Cable specification remote version .....	12	FOUNDATION Fieldbus certification .....	46
<b>Performance characteristics</b> .....	<b>13</b>	PROFIBUS DP/PA certification .....	46
Reference operating conditions .....	13	Modbus RS485 certification .....	46
Maximum measured error .....	13	Pressure Equipment Directive .....	47
Repeatability .....	14	Other standards and guidelines .....	47
Influence of fluid temperature .....	14	<b>Ordering Information</b> .....	<b>47</b>
Influence of fluid pressure .....	14	<b>Accessories</b> .....	<b>48</b>
Design fundamentals .....	14	Device-specific accessories .....	48
<b>Installation</b> .....	<b>16</b>	Communication-specific accessories .....	48
Mounting location .....	16	Service-specific accessories .....	49
Orientation .....	17	System components .....	49
Installation instructions .....	18	<b>Documentation</b> .....	<b>50</b>
Inlet and outlet runs .....	18	<b>Registered trademarks</b> .....	<b>50</b>
Length of connecting cable .....	18		
Special mounting instructions .....	18		
<b>Environment</b> .....	<b>19</b>		
Ambient temperature range .....	19		
Storage temperature .....	19		
Degree of protection .....	19		
Shock resistance .....	19		
Vibration resistance .....	19		
Electromagnetic compatibility (EMC) .....	19		
<b>Process</b> .....	<b>19</b>		
Fluid temperature range .....	19		
Fluid density range .....	19		

## Function and system design

### Measuring principle

The measuring principle is based on the controlled generation of Coriolis forces. These forces are always present when both translational and rotational movements are superimposed.

$$F_C = 2 \cdot \Delta m (v \cdot \omega)$$

$F_C$  = Coriolis force

$\Delta m$  = moving mass

$\omega$  = rotational velocity

$v$  = velocity of the moving mass in rotating or oscillating system

The amplitude of the Coriolis force depends on the moving mass  $\Delta m$ , its velocity  $v$  in the system, and thus on the mass flow. Instead of a constant angular velocity  $\omega$ , the Promass sensor uses oscillation.

In the sensor, two parallel measuring tubes containing flowing fluid oscillate in antiphase, acting like a tuning fork. The Coriolis forces produced at the measuring tubes cause a phase shift in the tube oscillations (see illustration):

- At zero flow, in other words when the fluid is at a standstill, the two tubes oscillate in phase (1).
- Mass flow causes deceleration of the oscillation at the inlet of the tubes (2) and acceleration at the outlet (3).

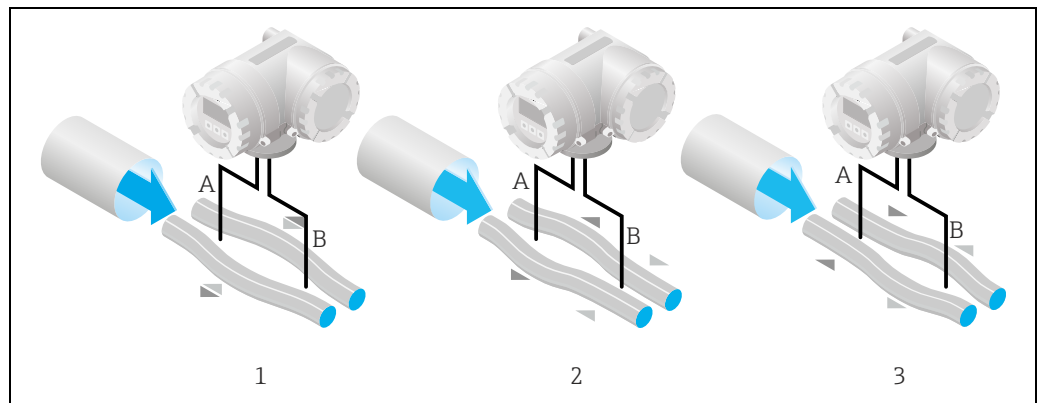

The phase difference (A-B) increases with increasing mass flow. Electrodynamic sensors register the tube oscillations at the inlet and outlet.

System balance is ensured by the antiphase oscillation of the two measuring tubes. The measuring principle operates independently of temperature, pressure, viscosity, conductivity and flow profile.

### Volume measurement

The measuring tubes are continuously excited at their resonance frequency. A change in the mass and thus the density of the oscillating system (comprising measuring tubes and fluid) results in a corresponding, automatic adjustment in the oscillation frequency. Resonance frequency is thus a function of fluid density. The density value obtained in this way can be used in conjunction with the measured mass flow to calculate the volume flow.

The temperature of the measuring tubes is also determined in order to calculate the compensation factor due to temperature effects.

**Measuring system**

The measuring system consists of a transmitter and a sensor. Two versions are available:

- Compact version: transmitter and sensor form a mechanical unit.
- Remote version: transmitter and sensor are mounted physically separate from one another.

**Transmitter**

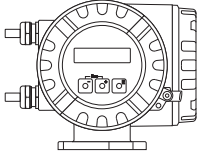
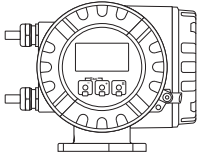
<p><b>Promass 80</b></p>  <p style="text-align: right; font-size: small;">a0003671</p>	<ul style="list-style-type: none"> <li>■ Two-line liquid-crystal display</li> <li>■ Operation with push buttons</li> </ul>
<p><b>Promass 83</b></p>  <p style="text-align: right; font-size: small;">a0003672</p>	<ul style="list-style-type: none"> <li>■ Four-line liquid-crystal display</li> <li>■ Operation with "Touch control"</li> <li>■ Application-specific Quick Setup</li> <li>■ Mass flow, volume flow, density and temperature measurement as well as calculated variables (e.g. fluid concentrations)</li> </ul>

**Sensor**

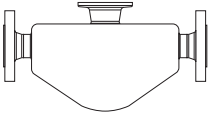
<p><b>E</b></p>  <p style="text-align: right; font-size: small;">a0002271</p>	<ul style="list-style-type: none"> <li>■ General purpose sensor, ideal replacement for volumetric flowmeters.</li> <li>■ Nominal diameters DN 8 to 80 (<math>\frac{3}{8}</math>" to 3")</li> <li>■ Material: <ul style="list-style-type: none"> <li>- Sensor: stainless steel, 1.4301 (304L)</li> <li>- Measuring tubes: stainless steel, 1.4539 (904L)</li> <li>- Process connections: stainless steel, 1.4404 (316/316L)</li> </ul> </li> </ul>
--	---

# Input

<b>Measured variable</b>	<ul style="list-style-type: none"> <li>Mass flow (proportional to the phase difference between two sensors mounted on the measuring tube to register a phase shift in the oscillation)</li> <li>Fluid density (proportional to resonance frequency of the measuring tube)</li> <li>Fluid temperature (measured with temperature sensors)</li> </ul>
--------------------------	---

**Measuring range** **Measuring ranges for liquids**

DN		Range for full scale values (liquids) $\dot{m}_{\min(F)}$ to $\dot{m}_{\max(F)}$	
[mm]	[inch]	[kg/h]	[lb/min]
8	3/8"	0 to 2000	0 to 73.50
15	1/2"	0 to 6500	0 to 238.9
25	1"	0 to 18000	0 to 661.5
40	1 1/2"	0 to 45000	0 to 1654
50	2"	0 to 70000	0 to 2573
80	3"	0 to 180000	0 to 6615

**Measuring ranges for gases**

The full scale values depend on the density of the gas. Use the formula below to calculate the full scale values:

$$\dot{m}_{\max(G)} = \dot{m}_{\max(F)} \cdot \rho_{(G)} \div x$$

$$\dot{m}_{\max(G)} = \text{max. full scale value for gas [kg/h]}$$

$$\dot{m}_{\max(F)} = \text{max. full scale value for liquid [kg/h]}$$

$$\rho_{(G)} = \text{Gas density in [kg/m}^3\text{] at operating conditions}$$

DN		X [kg/m <sup>3</sup> ]	DN		X [kg/m <sup>3</sup> ]
[mm]	[in]		[mm]	[in]	
8	3/8	85	40	3	125
15	1/2	110	50	4	125
25	1	125	80	6	155

Here,  $\dot{m}_{\max(G)}$  can never be greater than  $\dot{m}_{\max(F)}$

*Calculation example for gas:*

- Sensor type: Promass E, DN 50
- Gas: air with a density of 60.3 kg/m<sup>3</sup> (at 20 °C and 50 bar)
- Measuring range (liquid): 70000 kg/h
- x = 125 (for Promass E, DN 50)

Max. possible full scale value:

$$\dot{m}_{\max(G)} = \dot{m}_{\max(F)} \cdot \rho_{(G)} \div x \text{ [kg/m}^3\text{]} = 70000 \text{ kg/h} \cdot 60.3 \text{ kg/m}^3 \div 125 \text{ kg/m}^3 = 33800 \text{ kg/h}$$

*Recommended full scale values*

See information in the "Limiting flow" section → 23 ff.

<b>Operable flow range</b>	Greater than 1000: 1. Flow rates above the preset full scale value do not overload the amplifier, i.e. the totalizer values are registered correctly.
----------------------------	---

**Input signal****Status input (auxiliary input)**

$U = 3$  to  $30$  V DC,  $R_i = 5$  k $\Omega$ , galvanically isolated.

Configurable for: totalizer reset, positive zero return, error message reset, zero point adjustment start, batching start/stop (optional), batch totalizer reset (optional).

**Status input (auxiliary input) with PROFIBUS DP**

$U = 3$  to  $30$  V DC,  $R_i = 3$  k $\Omega$ , galvanically isolated.

Switch level:  $\pm 3$  to  $\pm 30$  V DC, independent of polarity.

Configurable for: positive zero return, error message reset, zero point adjustment start, batching start/stop (optional), totalizer reset for batching (optional).

**Status input (auxiliary input) with Modbus RS485**

$U = 3$  to  $30$  V DC,  $R_i = 3$  k $\Omega$ , galvanically isolated.

Switch level:  $\pm 3$  to  $\pm 30$  V DC, independent of polarity.

Configurable for: totalizer reset, positive zero return, error message reset, zero point adjustment start.

**Current input (only Promass 83)**

Active/passive selectable, galvanically isolated, resolution:  $2$   $\mu$ A

- Active:  $4$  to  $20$  mA,  $R_L < 700$   $\Omega$ ,  $U_{out} = 24$  V DC, short-circuit proof
- Passive:  $0/4$  to  $20$  mA,  $R_i = 150$   $\Omega$ ,  $U_{max} = 30$  V DC

**Output****Output signal****Promass 80***Current output*

Active/passive selectable, galvanically isolated, time constant selectable ( $0.05$  to  $100$  s), full scale value selectable, temperature coefficient: typically  $0.005\%$  o.f.s./ $^{\circ}$ C, resolution:  $0.5$   $\mu$ A

- Active:  $0/4$  to  $20$  mA,  $R_L < 700$   $\Omega$  (for HART:  $R_L \geq 250$   $\Omega$ )
- Passive:  $4$  to  $20$  mA; supply voltage  $U_S$   $18$  to  $30$  V DC;  $R_i \geq 150$   $\Omega$

*Pulse/frequency output*

Passive, open collector,  $30$  V DC,  $250$  mA, galvanically isolated.

- Frequency output: full scale frequency  $2$  to  $1000$  Hz ( $f_{max} = 1250$  Hz), on/off ratio  $1:1$ , pulse width max.  $2$  s
- Pulse output: pulse value and pulse polarity selectable, pulse width configurable ( $0.5$  to  $2000$  ms)

*PROFIBUS PA interface*

- PROFIBUS PA in accordance with EN 50170 Volume 2, IEC 61158-2 (MBP), galvanically isolated
- Profile Version 3.0
- Current consumption:  $11$  mA
- Permitted supply voltage:  $9$  to  $32$  V
- Bus connection with integrated reverse polarity protection
- Error current FDE (Fault Disconnection Electronic) =  $0$  mA
- Data transmission rate:  $31.25$  kBit/s
- Signal encoding: Manchester II
- Function blocks:  $4 \times$  Analog Input,  $2 \times$  Totalizer
- Output data: Mass flow, Volume flow, Density, Temperature, Totalizer
- Input data: Positive zero return (ON/OFF), Zero point adjustment, Measuring mode, Totalizer control
- Bus address can be configured via miniature switches or via the local display (optional)

**Promass 83***Current output*

Active/passive selectable, galvanically isolated, time constant selectable (0.05 to 100 s), full scale value selectable, temperature coefficient: typically 0.005% o.f.s./°C, resolution: 0.5  $\mu$ A

- Active: 0/4 to 20 mA,  $R_L < 700 \Omega$  (for HART:  $R_L \geq 250 \Omega$ )
- Passive: 4 to 20 mA; supply voltage  $U_S$  18 to 30 V DC;  $R_i \geq 150 \Omega$

*Pulse/frequency output*

active/passive selectable, galvanically isolated

- Active: 24 V DC, 25 mA (max. 250 mA during 20 ms),  $R_L > 100 \Omega$
- Passive: open collector, 30 V DC, 250 mA
- Frequency output: full scale frequency 2 to 10000 Hz ( $f_{max} = 12500$  Hz), on/off ratio 1:1, pulse width max. 2 s
- Pulse output: pulse value and pulse polarity selectable, pulse width configurable (0.05 to 2000 ms)

*HART protocol*

Order code "Power Supply; Display", option A, B, C, D, E, F, G, H, X, 7, 8 (HART 5)

- Valid until software version: 3.01.XX

Order code "Power Supply; Display", option P, Q, R, S, T, U, 4, 5 (HART 7)

- Valid as of software version: 3.07.XX

*PROFIBUS DP interface*

- PROFIBUS DP in accordance with EN 50170 Volume 2
- Profile Version 3.0
- Data transmission rate: 9.6 kBaud to 12 MBaud
- Automatic data transmission rate recognition
- Signal encoding: NRZ Code
- Function blocks: 6  $\times$  Analog Input, 3  $\times$  Totalizer
- Output data: Mass flow, Volume flow, Corrected volume flow, Density, Reference density, Temperature, Totalizers 1 to 3
- Input data: Positive zero return (ON/OFF), Zero point adjustment, Measuring mode, Totalizer control
- Bus address can be configured via miniature switches or via the local display (optional)
- Available output combination  $\rightarrow$  9

*PROFIBUS PA interface*

- PROFIBUS PA in accordance with EN 50170 Volume 2, IEC 61158-2 (MBP), galvanically isolated
- Data transmission rate: 31.25 kBit/s
- Current consumption: 11 mA
- Permitted supply voltage: 9 to 32 V
- Bus connection with integrated reverse polarity protection
- Error current FDE (Fault Disconnection Electronic): 0 mA
- Signal encoding: Manchester II
- Function blocks: 6  $\times$  Analog Input, 3  $\times$  Totalizer
- Output data: Mass flow, Volume flow, Corrected volume flow, Density, Reference density, Temperature, Totalizers 1 to 3
- Input data: Positive zero return (ON/OFF), Zero point adjustment, Measuring mode, Totalizer control
- Bus address can be configured via miniature switches or via the local display (optional)
- Available output combination  $\rightarrow$  9

*Modbus RS485 interface*

- Modbus RS485 device type: slave
- Address range: 1 to 247
- Supported function codes: 03, 04, 06, 08, 16, 23
- Broadcast: supported with the function codes 06, 16, 23
- Physical interface: RS485 in accordance with EIA/TIA-485 standard
- Supported baud rate: 1200, 2400, 4800, 9600, 19200, 38400, 57600, 115200 Baud
- Transmission mode: RTU or ASCII
- Response times:
  - Direct data access = typically 25 to 50 ms
  - Auto-scan buffer (data range) = typically 3 to 5 ms
- Possible output combination →  9

*FOUNDATION Fieldbus interface*

- FOUNDATION Fieldbus H1, IEC 61158-2, galvanically isolated
- Data transmission rate: 31.25 kBit/s
- Current consumption: 12 mA
- Permitted supply voltage: 9 to 32 V
- Error current FDE (Fault Disconnection Electronic): 0 mA
- Bus connection with integrated reverse polarity protection
- Signal encoding: Manchester II
- ITK Version 5.01
- Function blocks:
  - 8 × Analog Input (Execution time: per 18 ms)
  - 1 × Digital Output (18 ms)
  - 1 × PID (25 ms)
  - 1 × Arithmetic (20 ms)
  - 1 × Input Selector (20 ms)
  - 1 × Signal Characterizer (20 ms)
  - 1 × Integrator (18 ms)
- Number of VCRs: 38
- Number of link objects in VFD: 40
- Output data: Mass flow, Volume flow, Corrected volume flow, Density, Reference density, Temperature, Totalizers 1 to 3
- Input data: Positive zero return (ON/OFF), Zero point adjustment, Measuring mode, Reset totalizer
- Link Master (LM) function is supported

**Signal on alarm****Current output**

Failsafe mode selectable (e.g. in accordance with NAMUR Recommendation NE 43)

**Pulse/frequency output**

Failsafe mode selectable

**Status output (Promass 80)**

Nonconductive in the event of a fault or if the power supply fails

**Relay output (Promass 83)**

Dead in the event of a fault or if the power supply fails

**Load**

see "Output signal" →  6

**Low flow cutoff**

Switch points for low flow are selectable.

**Galvanic isolation**

All circuits for inputs, outputs, and power supply are galvanically isolated from each other.



**Switching output**

**Status output (Promass 80)**

- Open collector
- max. 30 V DC / 250 mA
- galvanically isolated
- Configurable for: error messages, Empty Pipe Detection (EPD), flow direction, limit values

**Relay output (Promass 83)**

- max. 30 V / 0.5 A AC; 60 V / 0.1 A DC
- galvanically isolated
- Normally closed (NC or break) or normally open (NO or make) contacts available (factory setting: relay 1 = NO, relay 2 = NC)

**Power supply**

**Terminal assignment**

**Promass 80**

Order characteristic for "inputs/outputs"	Terminal No. (inputs/outputs)			
	20 (+) / 21 (-)	22 (+) / 23 (-)	24 (+) / 25 (-)	26 (+) / 27 (-)
A	-	-	Frequency output	Current output, HART
D	Status input	Status output	Frequency output	Current output, HART
H	-	-	-	PROFIBUS PA
S	-	-	Frequency output Ex i, passive	Current output Ex i active, HART
T	-	-	Frequency output Ex i, passive	Current output Ex i passive, HART
8	Status input	Frequency output	Current output 2	Current output 1, HART

**Promass 83**

The inputs and outputs on the communication board can be either permanently assigned (fixed) or variable (flexible), depending on the version ordered (see table). Replacements for modules which are defective or which have to be replaced can be ordered as accessories.

Order characteristic for "inputs/outputs"	Terminal No. (inputs/outputs)			
	20 (+) / 21 (-)	22 (+) / 23 (-)	24 (+) / 25 (-)	26 (+) / 27 (-)
<i>Fixed communication boards (permanent assignment)</i>				
A	-	-	Frequency output	Current output, HART
B	Relay output	Relay output	Frequency output	Current output, HART
F	-	-	-	PROFIBUS PA, Ex i
G	-	-	-	FOUNDATION Fieldbus Ex i
H	-	-	-	PROFIBUS PA
J	-	-	+5V (ext. termination)	PROFIBUS DP
K	-	-	-	FOUNDATION Fieldbus
Q	-	-	Status input	Modbus RS485
R	-	-	Current output 2 Ex i, active	Current output 1 Ex i active, HART
S	-	-	Frequency output Ex i, passive	Current output Ex i active, HART

Order characteristic for "inputs/outputs"	Terminal No. (inputs/outputs)			
	20 (+) / 21 (-)	22 (+) / 23 (-)	24 (+) / 25 (-)	26 (+) / 27 (-)
T	-	-	Frequency output Ex i, passive	Current output Ex i passive, HART
U	-	-	Current output 2 Ex i, passive	Current output 1 Ex i passive, HART
<i>Flexible communication boards</i>				
C	Relay output 2	Relay output 1	Frequency output	Current output, HART
D	Status input	Relay output	Frequency output	Current output, HART
E	Status input	Relay output	Current output 2	Current output 1, HART
L	Status input	Relay output 2	Relay output 1	Current output, HART
M	Status input	Freq.output 2	Frequency output 1	Current output, HART
N	Current output	Frequency output	Status input	Modbus RS485
P	Current output	Frequency output	Status input	PROFIBUS DP
V	Relay output 2	Relay output 1	Status input	PROFIBUS DP
W	Relay output	Current output 3	Current output 2	Current output 1, HART
0	Status input	Current output 3	Current output 2	Current output 1, HART
2	Relay output	Current output 2	Frequency output	Current output 1, HART
3	Current input	Relay output	Current output 2	Current output 1, HART
4	Current input	Relay output	Frequency output	Current output, HART
5	Status input	Current input	Frequency output	Current output, HART
6	Status input	Current input	Current output 2	Current output 1, HART
7	Relay output 2	Relay output 1	Status input	Modbus RS485

**Supply voltage** 85 to 260 V AC, 45 to 65 Hz  
20 to 55 V AC, 45 to 65 Hz  
16 to 62 V DC

**Power consumption** AC: <15 VA (including sensor)  
DC: <15 W (including sensor)

*Switch-on current*

- Max. 13.5 A (<50 ms) at 24 V DC
- Max. 3 A (<5 ms) at 260 V AC

**Power supply failure** **Promass 80**

Lasting min. 1 power cycle:

- EEPROM saves measuring system data if the power supply fails
- HistoROM/S-DAT: exchangeable data storage chip with sensor specific data (nominal diameter, serial number, calibration factor, zero point, etc.)

**Promass 83**

Lasting min. 1 power cycle:

- EEPROM and T-DAT save the measuring system data if the power supply fails.
- HistoROM/S-DAT: exchangeable data storage chip with sensor specific data (nominal diameter, serial number, calibration factor, zero point, etc.)

Electrical connection

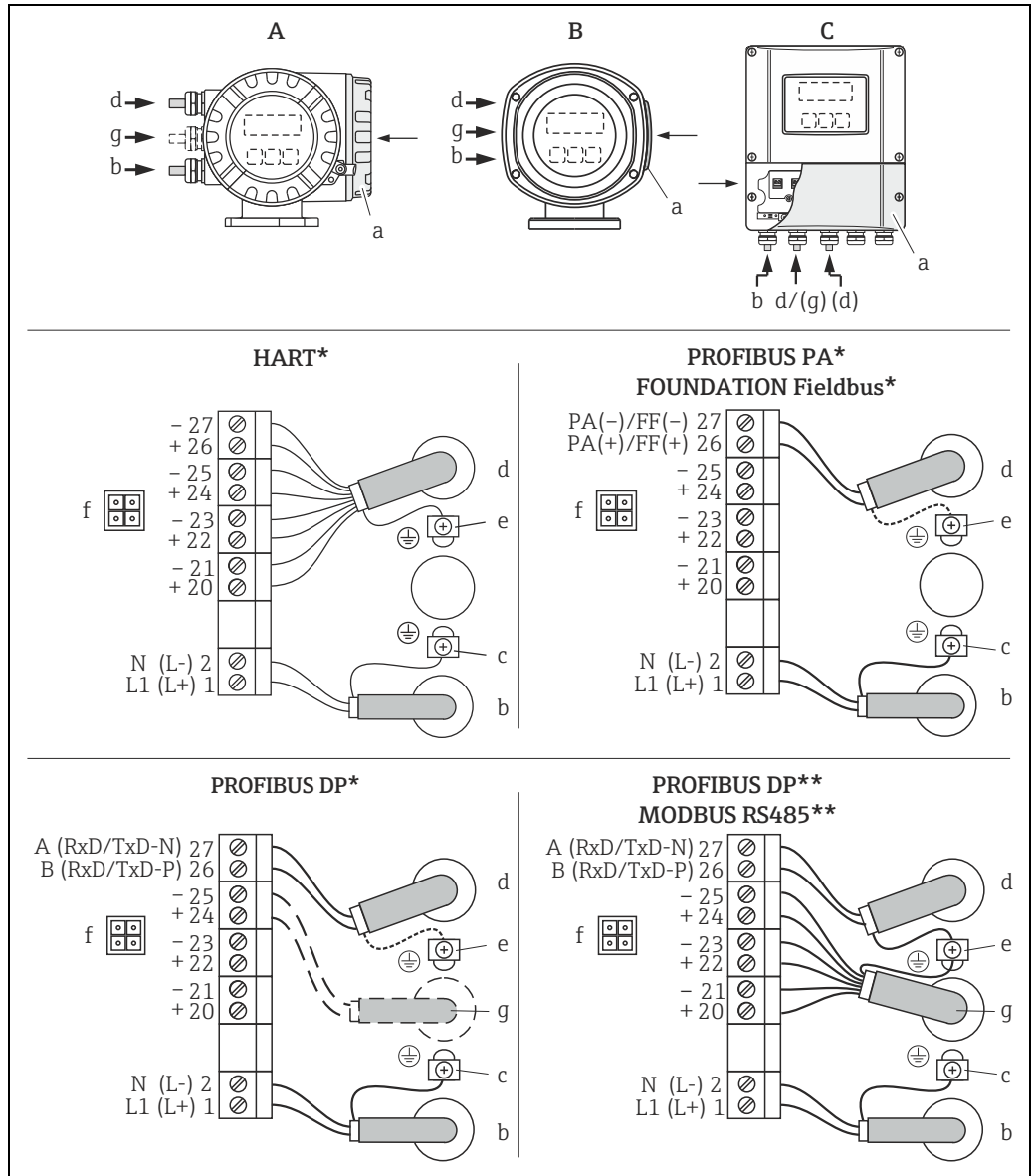

Connecting the transmitter, cable cross-section: max. 2.5 mm<sup>2</sup>

- A View A (field housing)
- B View B (Stainless Steel field housing)
- C View C (wall-mount housing)

\*) fixed communication board

\*\*) flexible communication board

a Connection compartment cover

b Cable for power supply: 85 to 260 V AC, 20 to 55 V AC, 16 to 62 V DC

Terminal No. 1: L1 for AC, L+ for DC

Terminal No. 2: N for AC, L- for DC

c Ground terminal for protective ground

d Signal cable: see Terminal assignment → 9

Fieldbus cable:

Terminal No. 26: DP (B) / PA (+) / FF (+) / Modbus RS485 (B) / (PA, FF: with reverse polarity protection)

Terminal No. 27: DP (A) / PA (-) / FF (-) / Modbus RS485 (A) / (PA, FF: with reverse polarity protection)

e Ground terminal for signal cable shield / fieldbus cable / RS485 line

f Service adapter for connecting service interface FXA 193 (Fieldcheck, FieldCare)

g Signal cable: see Terminal assignment → 9

g Cable for external termination (only for PROFIBUS DP with permanent assignment communication board):

Terminal No. 24: +5 V

Terminal No. 25: DGND

### Electrical connection remote version

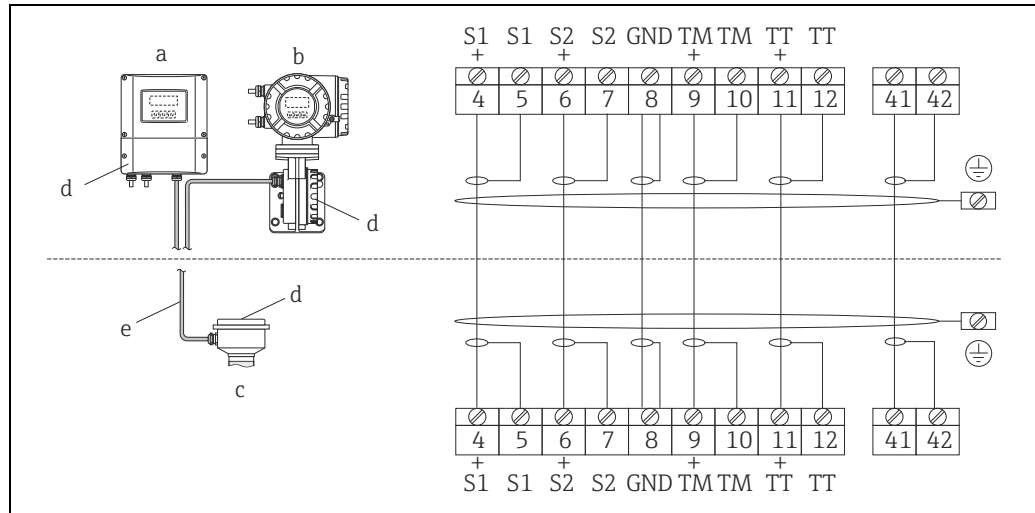

#### Connecting the remote version

- a Wall-mount housing: non-hazardous area and ATEX II3G / zone 2 → see separate "Ex documentation"  
 b Wall-mount housing: ATEX II2G / Zone 1 /FM/CSA → see separate "Ex documentation"  
 c Connection housing sensor  
 d Cover for connection compartment or connection housing  
 e Connecting cable

Terminal No.: 4/5 = gray; 6/7 = green; 8 = yellow; 9/10 = pink; 11/12 = white; 41/42 = brown

### Potential equalization

No special measures for potential equalization are required. For instruments for use in hazardous areas, observe the corresponding guidelines in the specific Ex documentation.

### Cable entries

#### Power-supply and signal cables (inputs/outputs):

- Cable entry M20 × 1.5 (8 to 12 mm / 0.31" to 0.47")
- Thread for cable entries, ½" NPT, G ½"

#### Connecting cable for remote version:

- Cable entry M20 × 1.5 (8 to 12 mm / 0.31" to 0.47")
- Thread for cable entries, ½" NPT, G ½"

### Cable specification remote version

- 6 × 0.38 mm<sup>2</sup> PVC cable with common shield and individually shielded cores
- Conductor resistance: ≤ 50 Ω/km (≤0.015 Ω/ft)
- Capacitance: core/shield: ≤ 420 pF/m (≤128 pF/ft)
- Cable length: max. 20 m (65 ft)
- Permanent operating temperature: max. +105 °C (+221 °F)

#### Operation in zones of severe electrical interference:

The measuring device complies with the general safety requirements in accordance with EN 61010-1, the EMC requirements of IEC/EN 61326, and NAMUR recommendation NE 21/43.

## Performance characteristics

### Reference operating conditions

- Error limits following ISO/DIN 11631
- Water, typically +15...+45 °C (+59...+113 °F); 2...6 bar (29...87 psi)
- Data according to calibration protocol
- Accuracy based on accredited calibration rigs according to ISO 17025

### Maximum measured error

o.r. = of reading;  $1 \text{ g/cm}^3 = 1 \text{ kg/l}$ ; T = medium temperature

The following values refer to the pulse/frequency output. Measured error at the current output is typically  $\pm 5 \mu\text{A}$ .

#### Base accuracy

Design fundamentals →  14

#### Mass flow (liquids)

Promass 83E:

- $\pm 0.15\%$  o.r.
- Calibration option:  $\pm 0.10\%$  o.r.

Promass 80E:

- $\pm 0.20\%$  o.r.

#### Volume flow (liquids)

Specification under reference operating conditions

- Promass 83E:  $\pm 0.15\%$  v.M.
- Promass 80E:  $\pm 0.20\%$  v.M.

#### Mass flow (gases)

$\pm 0.75\%$  o.r.

#### Density (liquids)

- Reference conditions:  $\pm 0.0005 \text{ g/cm}^3$
- Field density calibration:  $\pm 0.0005 \text{ g/cm}^3$   
(valid after a field density calibration under process conditions)
- Standard density calibration:  $\pm 0.02 \text{ g/cm}^3$   
(valid over the entire temperature and density range →  19)

#### Temperature

$\pm 0.5 \text{ °C} \pm 0.005 \cdot T \text{ °C}$  ( $\pm 1 \text{ °F} \pm 0.003 \cdot (T - 32) \text{ °F}$ )

### Zero point stability

DN		Zero point stability	
[mm]	[inch]	[kg/h] or [l/h]	[lb/min]
8	$\frac{3}{8}$ "	0.20	0.0074
15	$\frac{1}{2}$ "	0.65	0.0239
25	1"	1.80	0.0662
40	$1\frac{1}{2}$ "	4.50	0.1654
50	2"	7.00	0.2573
80	3"	18.00	0.6615

**Repeatability****Base repeatability**Design fundamentals → [14](#).*Mass flow and volume flow (liquids)*

Promass 83E:

- $\pm 0.075\%$  o.r.
- Calibration option mass flow 0.1%:  $\pm 0.05\%$  o.r.

Promass 80E:

- $\pm 0.10\%$  o.r.

*Mass flow (gases)* $\pm 0.35\%$  o.r.*Density (liquids)* $\pm 0.00025$  g/cm<sup>3</sup>*Temperature* $\pm 0.25$  °C  $\pm 0.0025 \cdot T$  °C ( $\pm 1$  °F  $\pm 0.003 \cdot (T - 32)$  °F)**Influence of fluid temperature**

When there is a difference between the temperature for zero point adjustment and the process temperature, the typical measured error of the Promass sensor is  $\pm 0.0002\%$  of the full scale value / °C ( $\pm 0.0001\%$  of the full scale value / °F).

**Influence of fluid pressure**

The table below shows the effect on accuracy of mass flow due to a difference between calibration pressure and process pressure.

DN		Promass E
[mm]	[inch]	[% o.r./bar]
8	$\frac{3}{8}$ "	no influence
15	$\frac{1}{2}$ "	no influence
25	1"	no influence
40	$1\frac{1}{2}$ "	no influence
50	2"	-0.009
80	3"	-0.020

o.r. = of reading

**Design fundamentals**

o.r. = of reading

BaseAccu = base accuracy in % o.r.

BaseRepeat = base repeatability in % o.r.

MeasValue = measured value (in flow units consistent with the zero point stability value → [13](#))

ZeroPoint = zero point stability

**Calculation of the maximum measured error depending on flowrate**

Flowrate (in flow units consistent with the zero point stability value → <a href="#">13</a> )	Maximum measured error in % o.r.
$\geq \frac{\text{ZeroPoint}}{\text{BaseAccu}} \cdot 100$ <small>A0021332</small>	$\pm \text{BaseAccu}$ <small>A0021339</small>
$< \frac{\text{ZeroPoint}}{\text{BaseAccu}} \cdot 100$ <small>A0021333</small>	$\pm \frac{\text{ZeroPoint}}{\text{MeasValue}} \cdot 100$ <small>A0021334</small>

**Calculation of the repeatability depending on flowrate**

Flowrate (in flow units consistent with the zero point stability value → 13)	Repeatability in % o.r.
$\geq \frac{\frac{1}{2} \cdot \text{ZeroPoint}}{\text{BaseRepeat}} \cdot 100$ <small>A0021335</small>	$\pm \text{BaseRepeat}$ <small>A0021340</small>
$< \frac{\frac{1}{2} \cdot \text{ZeroPoint}}{\text{BaseRepeat}} \cdot 100$ <small>A0021336</small>	$\pm \frac{1}{2} \cdot \frac{\text{ZeroPoint}}{\text{MeasValue}} \cdot 100$ <small>A0021337</small>

**Example for maximum measured error**

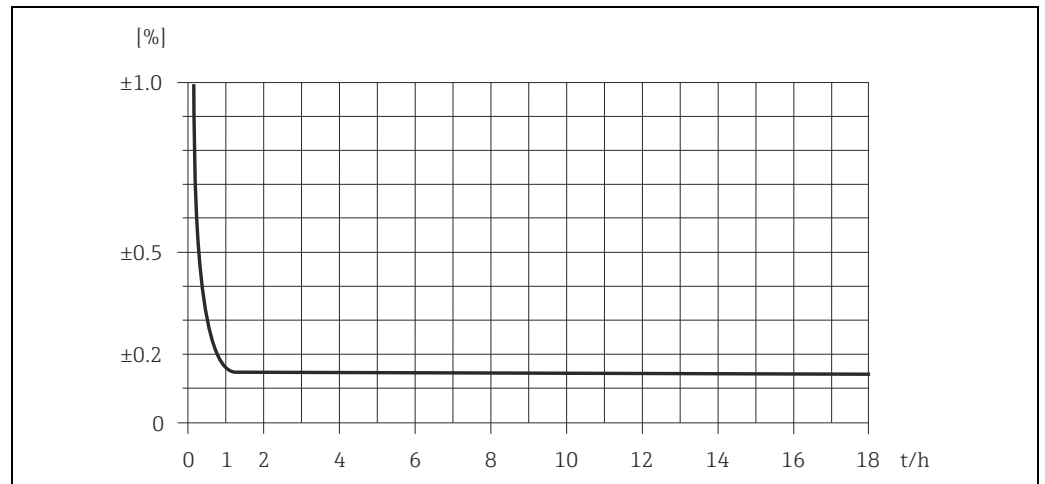

Maximum measured error in % of measured value (example: Promass 83E / DN 25)

*Flow values (example)*

Turn down	Flow		Max. measured error [% o.r.]
	[kg/h]	[lb/min]	
250 : 1	72	2.646	2.50
100 : 1	180	6.615	1.00
25 : 1	720	26.46	0.25
10 : 1	1800	66.15	0.15
2 : 1	9000	330.75	0.15

o.r. = of reading

## Installation

### Mounting location

Entrained air or gas bubbles in the measuring tube can result in an increase in measuring errors.

**Therefore, avoid** the following mounting locations in the pipe installation:

- Highest point of a pipeline. Risk of air accumulating.
- Directly upstream of a free pipe outlet in a vertical pipeline.

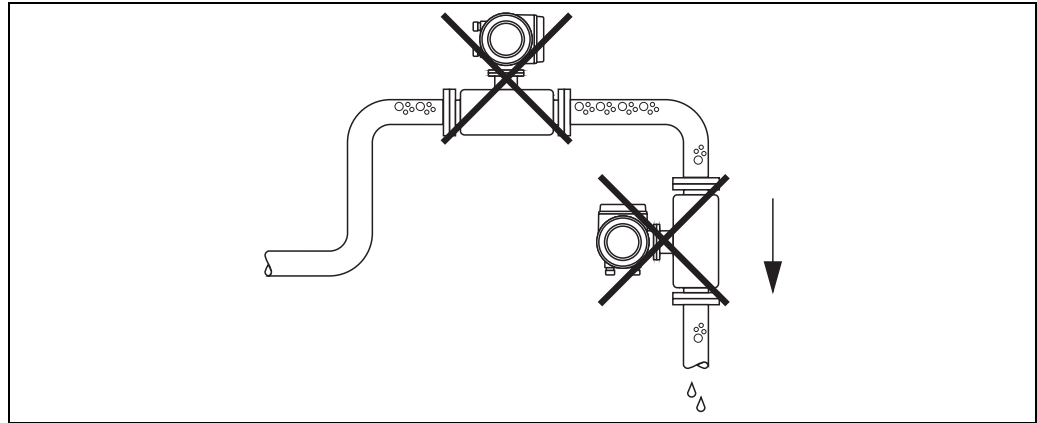

Mounting location

### Installation in down pipes

Notwithstanding the above, the installation proposal below permits installation in an open vertical pipeline. Pipe restrictions or the use of an orifice with a smaller cross-section than the nominal diameter prevent the sensor running empty while measurement is in progress.

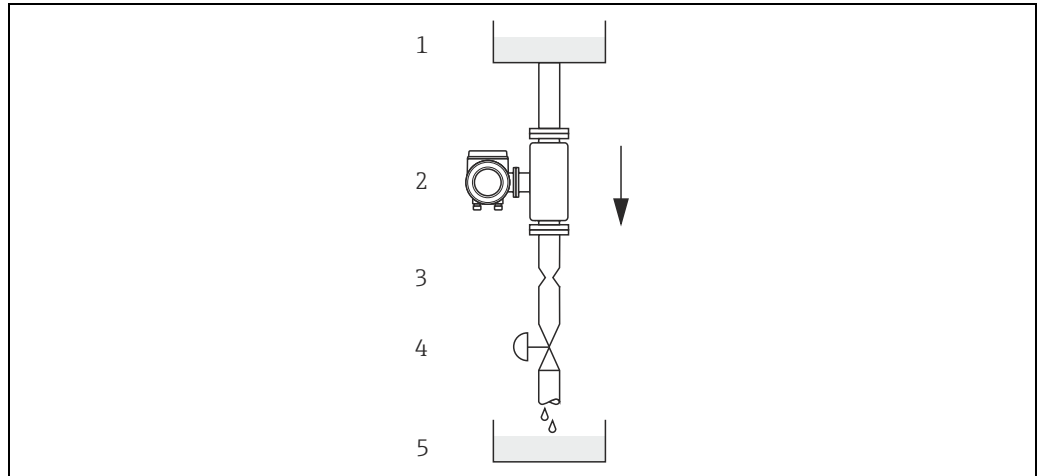

Installation in a down pipe (e.g. for batching applications)

- 1 Supply tank
- 2 Sensor
- 3 Orifice plate, pipe restriction (see Table following page)
- 4 Valve
- 5 Batching tank

DN		Ø Orifice plate, pipe restriction	
[mm]	[inch]	[mm]	[inch]
8	3/8"	6	0.24
15	1/2"	10	0.40
25	1"	14	0.55
40	1 1/2"	22	0.87



DN		Ø Orifice plate, pipe restriction	
[mm]	[inch]	[mm]	[inch]
50	2"	28	1.10
80	3"	50	2.00

**Orientation**



Make sure that the direction of the arrow on the nameplate of the sensor matches the direction of flow (direction of fluid flow through the pipe).

**Vertical (Fig. V)**

Recommended orientation with upward direction of flow. When fluid is not flowing, entrained solids will sink down and gases will rise away from the measuring tube. Thus the measuring tubes can be completely drained and protected against solids buildup.

**Horizontal (Fig. H1 / H2)**

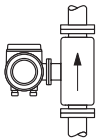
The measuring tubes must be horizontal and beside each other. When installation is correct the transmitter housing is above or below the pipe (Fig. H1/H2). Always avoid having the transmitter housing in the same horizontal plane as the pipe. Please note the special installation instructions → 18.

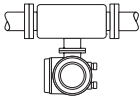
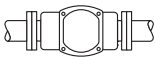
Orientation		Promass E compact version	Promass E remote version
<b>Fig. V:</b> Vertical	 <small>a0004572</small>	✓✓	✓✓
<b>Fig. H1:</b> Horizontal Transmitter head up	 <small>a0004576</small>	✓✓	✓✓
<b>Fig. H2:</b> Horizontal Transmitter head down	 <small>a0004580</small>	✓✓	✓✓
<b>Fig. H3:</b> Horizontal Transmitter head to the side	 <small>a0007558</small>	x	x
✓✓ = Recommended orientation ✓ = Orientation recommended in certain situations x = Impermissible orientation			

In order to ensure that the permissible ambient temperature range for the transmitter is not exceeded, we recommend the following orientations:

- For fluids with very high temperatures, we recommend the horizontal orientation with the transmitter head pointing downwards (Fig. H2) or the vertical orientation (Fig. V).
- For fluids with very low temperatures, we recommend the horizontal orientation with the transmitter head pointing upwards (Fig. H1) or the vertical orientation (Fig. V).

## Installation instructions

Note the following points:

- No special measures such as supports are necessary. External forces are absorbed by the construction of the instrument, for example the secondary containment.
- The high oscillation frequency of the measuring tubes ensures that the correct operation of the measuring system is not influenced by pipe vibrations.
- No special precautions need to be taken for fittings which create turbulence (valves, elbows, T-pieces etc.), as long as no cavitation occurs.

### Horizontal installation

When using a bent measuring tube and horizontal installation, the position of the sensor has to be matched to the fluid properties!

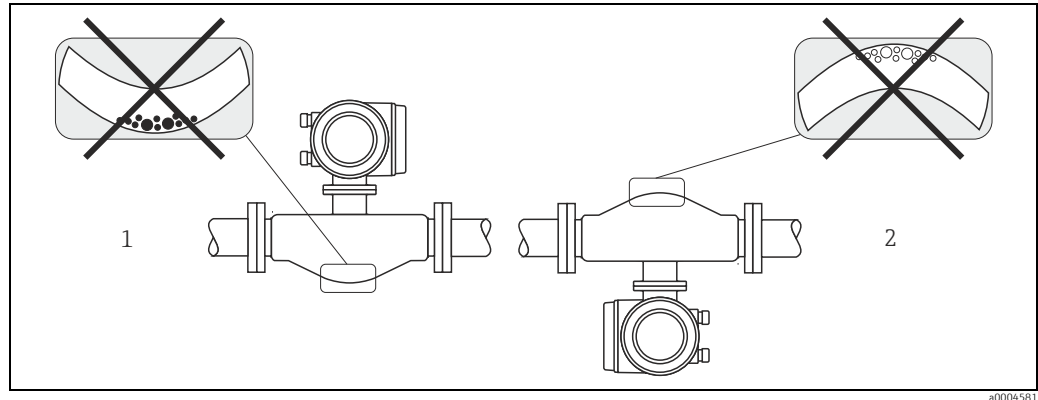

Horizontal installation for sensors with a bent measuring tube

- 1 Not suitable for fluids with entrained solids. Risk of solids accumulating.
- 2 Not suitable for outgassing fluids. Risk of air accumulating.

### Zero point adjustment

All measuring devices are calibrated with state-of-the-art technology. The zero point determined in this way is imprinted on the nameplate of the device. Calibration takes place under reference operating conditions → 13. Consequently, the zero point adjustment is generally **not** necessary for Promass!

Experience shows that the zero point adjustment is advisable only in special cases:

- To achieve highest measuring accuracy also with very small flow rates.
- Under extreme process or operating conditions (e.g. very high process temperatures or very high viscosity fluids).

### Inlet and outlet runs

There are no installation requirements regarding inlet and outlet runs.

### Length of connecting cable

Max. 20 meters (66 ft), remote version

### Special mounting instructions

#### Rupture disk

Make sure that the function and operation of the rupture disk is not impeded through the installation of the device. The position of the rupture disk is indicated on a sticker applied over it. If the rupture disk is triggered, the sticker is destroyed. The disk can therefore be visually monitored.

For additional information that is relevant to the process → 23

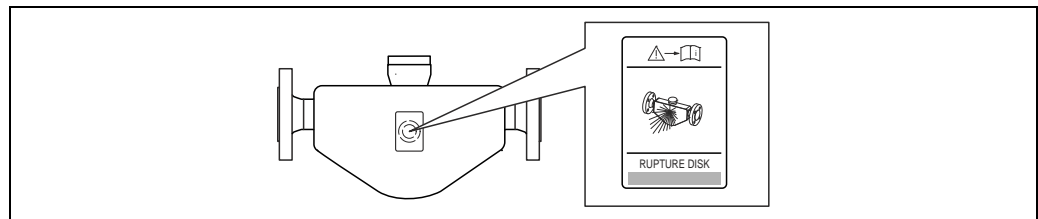

Rupture disk label

## Environment

<b>Ambient temperature range</b>	Sensor, transmitter: <ul style="list-style-type: none"> <li>■ Standard: -20 to +60 °C (-4 to +140 °F)</li> <li>■ Optional: -40 to +60 °C (-40 to +140 °F)</li> </ul>
	 <p>Note!</p> <ul style="list-style-type: none"> <li>■ Install the device at a shady location. Avoid direct sunlight, particularly in warm climatic regions.</li> <li>■ At ambient temperatures below -20 °C (-4 °F) the readability of the display may be impaired.</li> </ul>
<b>Storage temperature</b>	-40 to +80 °C (-40 to +175 °F), preferably +20 °C (+68 °F)
<b>Degree of protection</b>	Standard: IP 67 (NEMA 4X) for transmitter and sensor
<b>Shock resistance</b>	According to IEC 68-2-31
<b>Vibration resistance</b>	Acceleration up to 1 g, 10 to 150 Hz, following IEC 68-2-6
<b>Electromagnetic compatibility (EMC)</b>	As per IEC/EN 61326 and NAMUR recommendation NE 21

## Process

<b>Fluid temperature range</b>	<b>Sensor</b> -40 to +140 °C (-40 to +284 °F)
<b>Fluid density range</b>	0 to 5000 kg/m <sup>3</sup> (0 to +312 lb/ft <sup>3</sup> )
<b>Medium pressure range (nominal pressure)</b>	<b>Flanges</b> <ul style="list-style-type: none"> <li>■ according to DIN: PN 40 to 100</li> <li>■ according to ASME B16.5: Cl 150, Cl 300, Cl 600</li> <li>■ JIS: 10K, 20K, 40K, 63K</li> </ul> <b>Secondary containment pressure rating</b> The sensor housing is filled with dry nitrogen and protects the electronics and mechanics inside. The housing does not have pressure vessel classification. Reference value for the pressure loading capacity of the sensor housing: 16 bar (232 psi).

**Pressure-temperature ratings**

The following pressure-temperature ratings refer to the entire device and not just the process connection.

**Flange connection according to EN 1092-1 (DIN 2501)**

Flange material: 1.4404 (F316/F316L)

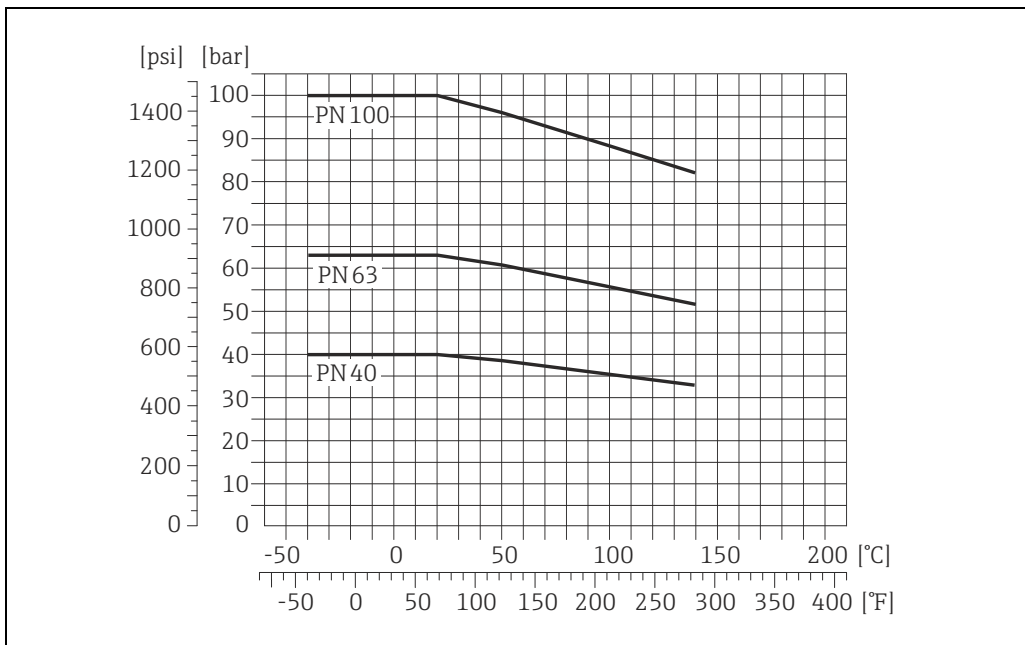

A0020972-EN

**Flange connection according to ASME B16.5**

Flange material: 1.4404 (F316/F316L)

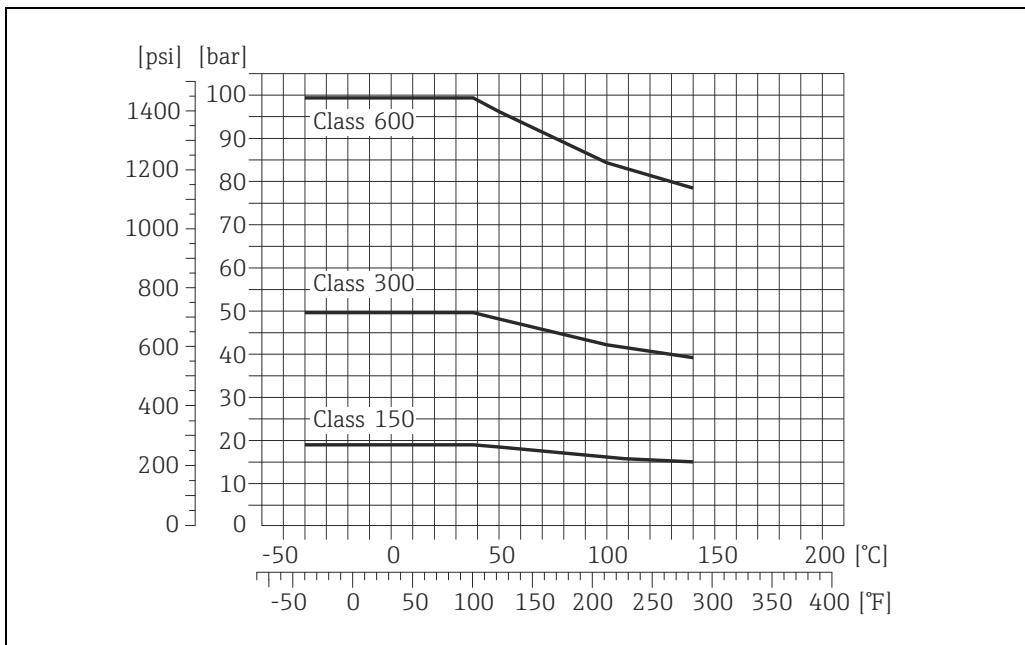

A0020973-EN

**JIS B2220, flange**

Flange material: 1.4404 (F316/F316L)

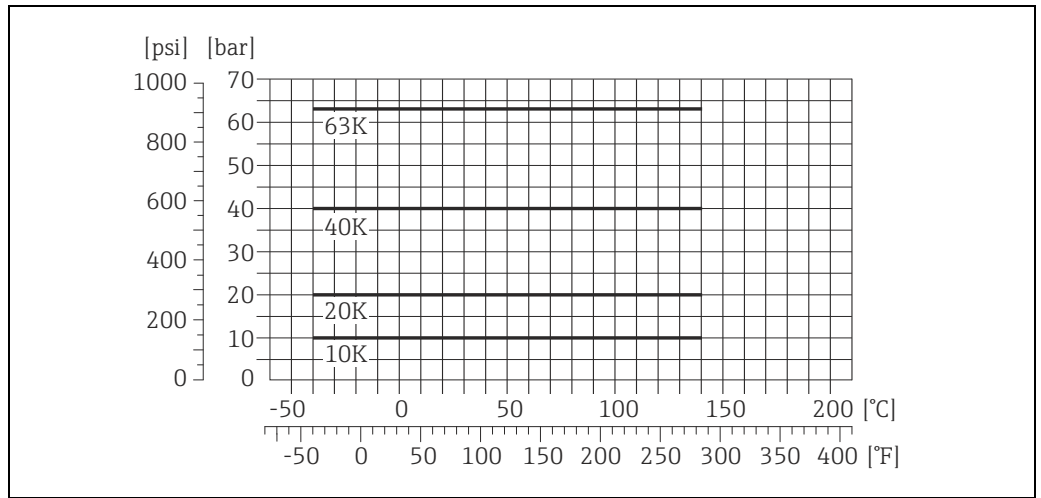

A0020974-EN

**Tri-Clamp process connection**

The Clamp connections are suited up to a maximum pressure of 16 bar (232 psi). Please observe the operating limits of the clamp and seal used as they could be under 16 bar (232 psi). The clamp and the seal are not included in the scope of supply.

**DIN 11851, thread**

Connection material: 1.4404 (316/316L)

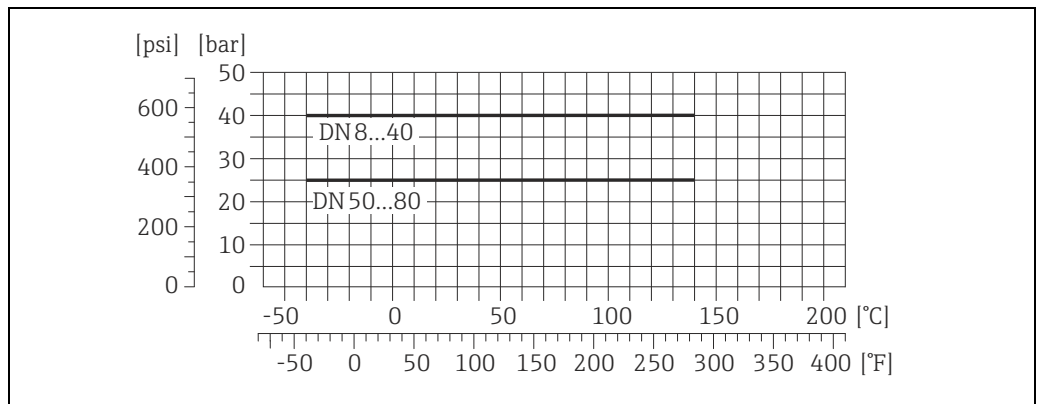

A0020976-EN

*DIN 11851 allows for applications up to +140 °C (+284 °F) if suitable sealing materials are used. Please take this into account when selecting seals and counterparts as these components can limit the pressure and temperature range.*

**DIN 11864-1 Form A, thread**

Connection material: 1.4404 (316/316L)

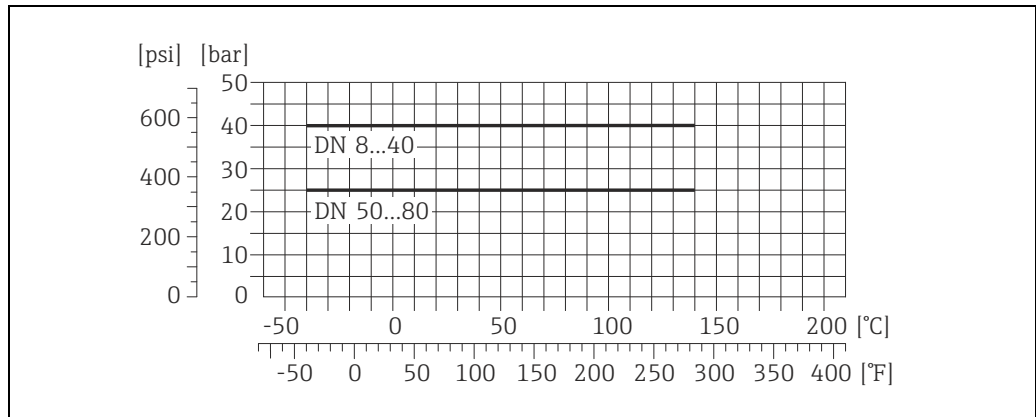

A0020977-EN

**DIN 11864-2 Form A, flange**

Flange material: 1.4404 (316/316L)

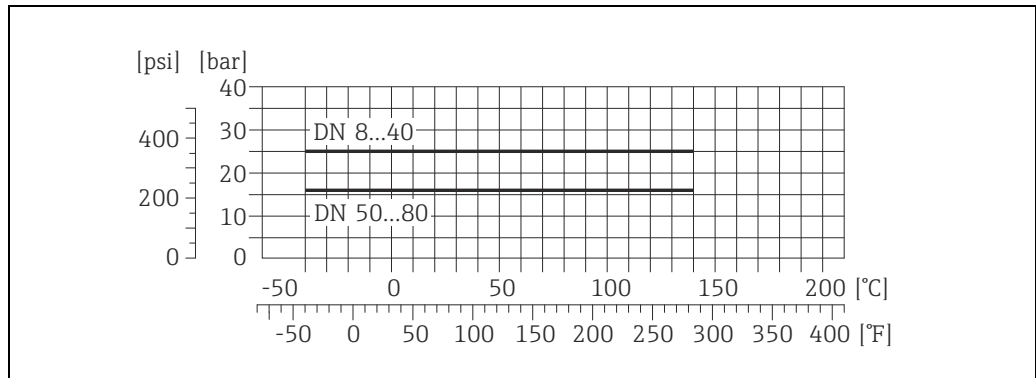

A0020978-EN

**SMS 1145, thread**

Connection material: 1.4404 (316/316L)

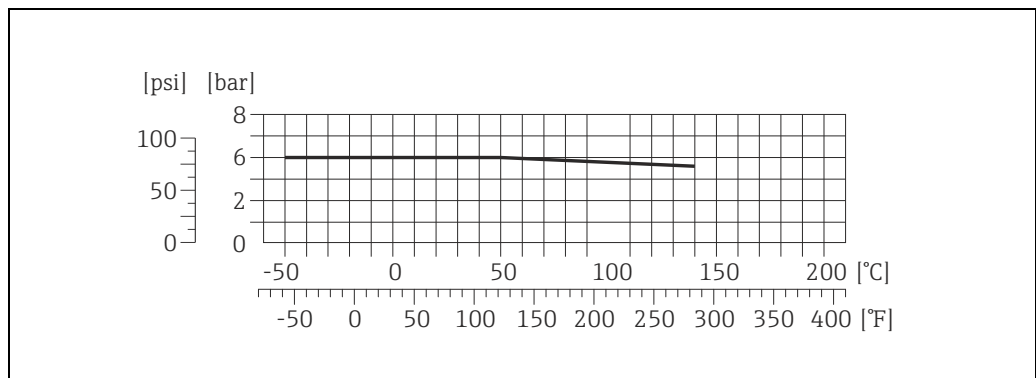

A0020986-EN

SMS 1145 allows for applications up to 6 bar (87 psi) if suitable sealing materials are used. Please take this into account when selecting seals and counterparts as these components can limit the pressure and temperature range.

**ISO 2853, thread**

Connection material: 1.4404 (316/316L)

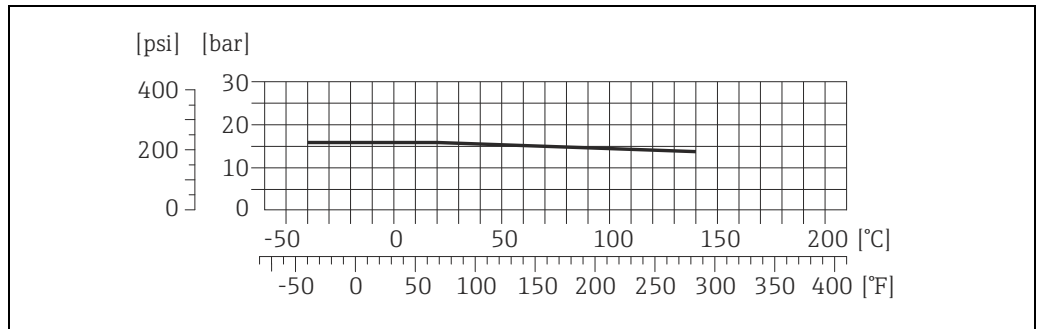

A0020988-EN

**VCO process connection**

Flange material: 1.4404 (316/316L)

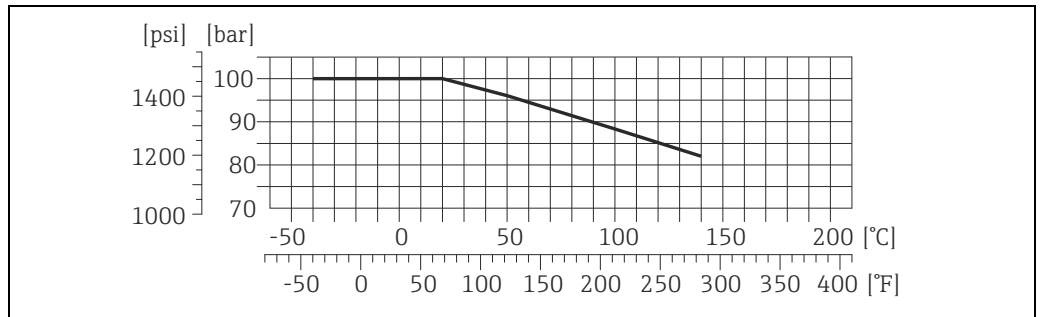

A0020975-EN

**Rupture disk**

To increase the level of safety, a device version with a rupture disk with a triggering pressure of 10 to 15 bar (145 to 217.5 psi) can be used. Special mounting instructions: → 18

Rupture disks cannot be combined with the separately available heating jacket → 48.

**Limiting flow**

See information in the "Measuring range" section → 5.

Select nominal diameter by optimizing between required flow range and permissible pressure loss. See the "Measuring range" section for a list of maximum possible full scale values.

- The minimum recommended full scale value is approx. 1/20 of the max. full scale value
- In most applications, 20 to 50% of the maximum full scale value can be considered ideal
- Select a lower full scale value for abrasive substances such as fluids with entrained solids (flow velocity <1 m/s (<3 ft/s))
- For gas measurement the following rules apply:
  - Flow velocity in the measuring tubes should not be more than half the sonic velocity (0.5 Mach)
  - The maximum mass flow depends on the density of the gas: formula → 5

**Pressure loss**

To calculate the pressure loss, use the *Applicator* sizing tool (→ 49).

**System pressure**

It is important to ensure that cavitation does not occur, because it would influence the oscillation of the measuring tube. No special measures need to be taken for fluids which have properties similar to water under normal conditions.

In the case of liquids with a low boiling point (hydrocarbons, solvents, liquefied gases) or in suction lines, it is important to ensure that pressure does not drop below the vapor pressure and that the liquid does not start to boil. It is also important to ensure that the gases that occur naturally in many liquids do not outgas. Such effects can be prevented when system pressure is sufficiently high.

Therefore, the following locations should be preferred for installation:

- Downstream from pumps (no danger of vacuum)
- At the lowest point in a vertical pipe

**Thermal insulation**

Some fluids require suitable measures to avoid loss of heat at the sensor. A wide range of materials can be used to provide the required thermal insulation.

**Heating**

Some fluids require suitable measures to avoid heat transfer at the sensor. Heating can be electric, e.g. with heated elements, or by means of hot water or steam pipes made of copper or heating jackets.



Caution!

- Risk of electronics overheating! Make sure that the maximum permissible ambient temperature for the transmitter is not exceeded. Consequently, make sure that the adapter between the sensor and transmitter and the connection housing of the remote version always remain free of insulating material. Note that a certain orientation might be required, depending on the fluid temperature → [19](#).

- If using an electric trace heating system whose heating is regulated via phase angle control or pulse packages, influence on the measured values cannot be ruled out due to magnetic fields (i.e. for values that are greater than the values approved by the EN standard (sine 30 A/m)). In such cases, the sensor must be magnetically shielded.

The housing can be shielded with tin plates or electric sheets without preferential direction (e.g. V330-35A) with the following properties:

- Relative magnetic permeability  $\mu_r \geq 300$
- Plate thickness  $d \geq 0.35 \text{ mm}$  ( $d \geq 0.014''$ )

- Information on permitted temperature ranges → [19](#)

Special heating jackets, which can be ordered separately from Endress+Hauser as an accessory, are available for the sensors.



## Mechanical construction

### Design, dimensions

<b>Dimensions:</b>	
Field housing compact version, powder-coated die-cast aluminum	→ <a href="#">26</a>
Field housing compact version (II2G/Zone 1), powder-coated die-cast aluminum	→ <a href="#">27</a>
Transmitter connection housing remote version (II2G/Zone 1)	→ <a href="#">28</a>
Transmitter remote version, wall-mount housing (non hazardous area and II3G / zone 2)	→ <a href="#">29</a>
Sensor remote version, connection housing	→ <a href="#">30</a>
<b>Process connections in SI units</b>	
Flange connections EN (DIN)	→ <a href="#">31</a>
Flange connections ASME B16.5	→ <a href="#">33</a>
Flange connections JIS	→ <a href="#">34</a>
Tri-Clamp	→ <a href="#">35</a>
DIN 11851, thread, DIN11866 line A	→ <a href="#">36</a>
DIN 11864-1 Form A, thread, DIN11866 line A	→ <a href="#">37</a>
DIN 11864-2 Form A, flange, DIN11866 line A, flange with notch	→ <a href="#">38</a>
ISO 2853, thread, ISO2037	→ <a href="#">39</a>
SMS 1145, thread	→ <a href="#">40</a>
VCO connections	→ <a href="#">40</a>
<b>Process connections in SI units</b>	
Flange connections ASME B16.5	→ <a href="#">41</a>
Tri-Clamp	→ <a href="#">42</a>
SMS 1145, thread	→ <a href="#">43</a>
VCO connections	→ <a href="#">43</a>

## Field housing compact version, powder-coated die-cast aluminum

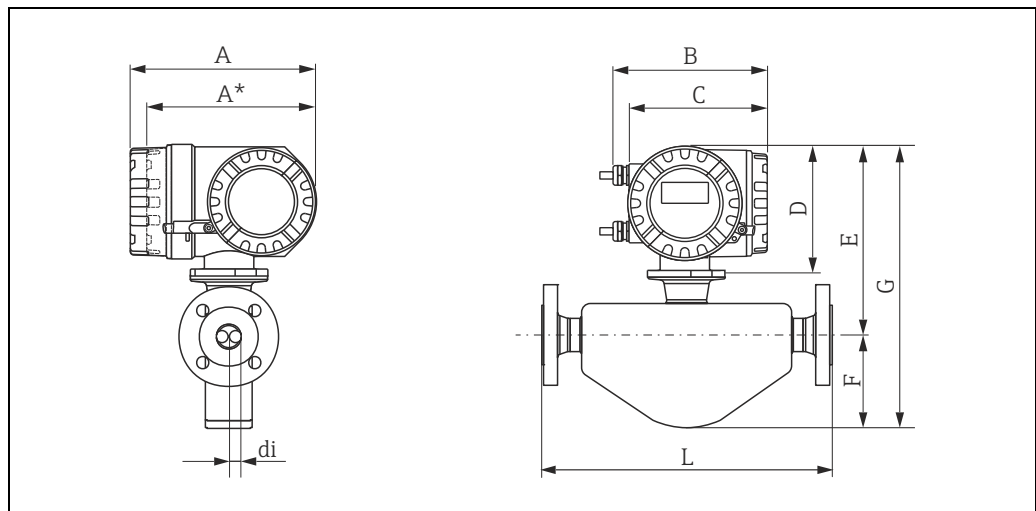

A0007638

## Dimensions SI units

DN	A	A*	B	C	D	E	F	G	L	di
8	227	207	187	168	160	224	93	317	1)	1)
15	227	207	187	168	160	226	105	331	1)	1)
25	227	207	187	168	160	231	106	337	1)	1)
40	227	207	187	168	160	237	121	358	1)	1)
50	227	207	187	168	160	253	170	423	1)	1)
80	227	207	187	168	160	282	205	487	1)	1)

1) dependent on respective process connection

\* Blind version (without local display)

All dimensions in [mm]

## Dimensions in US units

DN	A	A*	B	C	D	E	F	G	L	di
3/8"	9.08	8.28	7.48	6.72	6.40	8.82	3.66	12.48	2)	2)
1/2"	9.08	8.28	7.48	6.72	6.40	8.90	4.13	13.03	2)	2)
1"	9.08	8.28	7.48	6.72	6.40	9.09	4.17	13.27	2)	2)
1 1/2"	9.08	8.28	7.48	6.72	6.40	9.33	4.76	14.09	2)	2)
2"	9.08	8.28	7.48	6.72	6.40	9.96	6.69	16.65	2)	2)
3"	9.08	8.28	7.48	6.72	6.40	11.10	8.07	19.17	2)	2)

1) dependent on respective process connection

\* Blind version (without local display)

All dimensions in [inch]

Field housing compact version (II2G/Zone 1), powder-coated die-cast aluminum

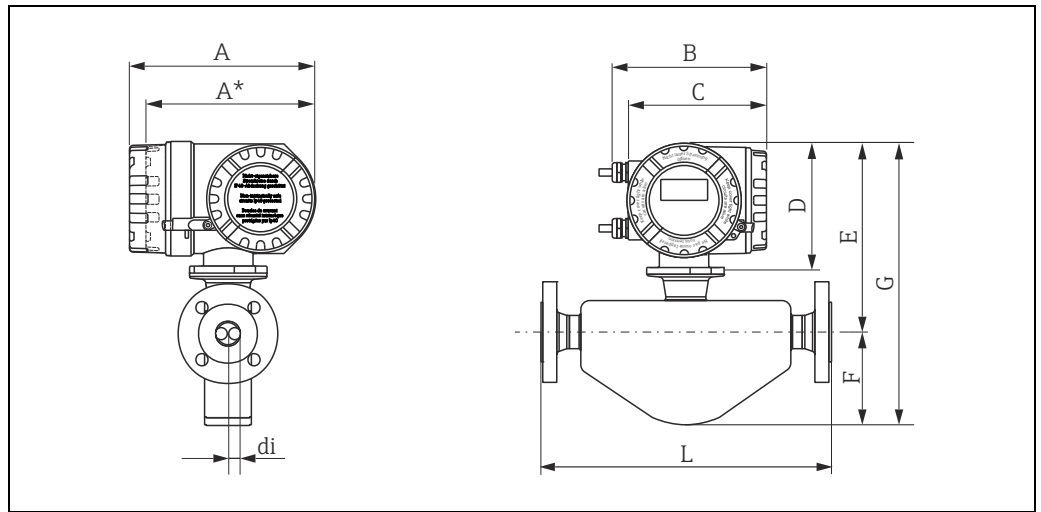

A0015135

Dimensions SI units

DN	A	A*	B	C	D	E	F	G	L	di
8	240	217	206	186	178	242	93	335	1)	1)
15	240	217	206	186	178	244	105	349	1)	1)
25	240	217	206	186	178	249	106	355	1)	1)
40	240	217	206	186	178	255	121	376	1)	1)
50	240	217	206	186	178	271	170	441	1)	1)
80	240	217	206	186	178	300	205	505	1)	1)

<sup>1)</sup> dependent on respective process connection

\* Blind version (without local display)

All dimensions in [mm]

Dimensions in US units

DN	A	A*	B	C	D	E	F	G	L	di
3/8"	9.45	8.54	8.11	7.32	7.01	9.52	3.66	13.18	1)	1)
1/2"	9.45	8.54	8.11	7.32	7.01	9.60	4.13	13.73	1)	1)
1"	9.45	8.54	8.11	7.32	7.01	9.79	4.17	13.97	1)	1)
1 1/2"	9.45	8.54	8.11	7.32	7.01	10.03	4.76	14.79	1)	1)
2"	9.45	8.54	8.11	7.32	7.01	10.66	6.69	17.35	1)	1)
3"	9.45	8.54	8.11	7.32	7.01	11.80	8.07	19.87	1)	1)

<sup>1)</sup> dependent on respective process connection

\* Blind version (without local display)

All dimensions in [inch]

## Transmitter connection housing remote version (II2G/Zone 1)

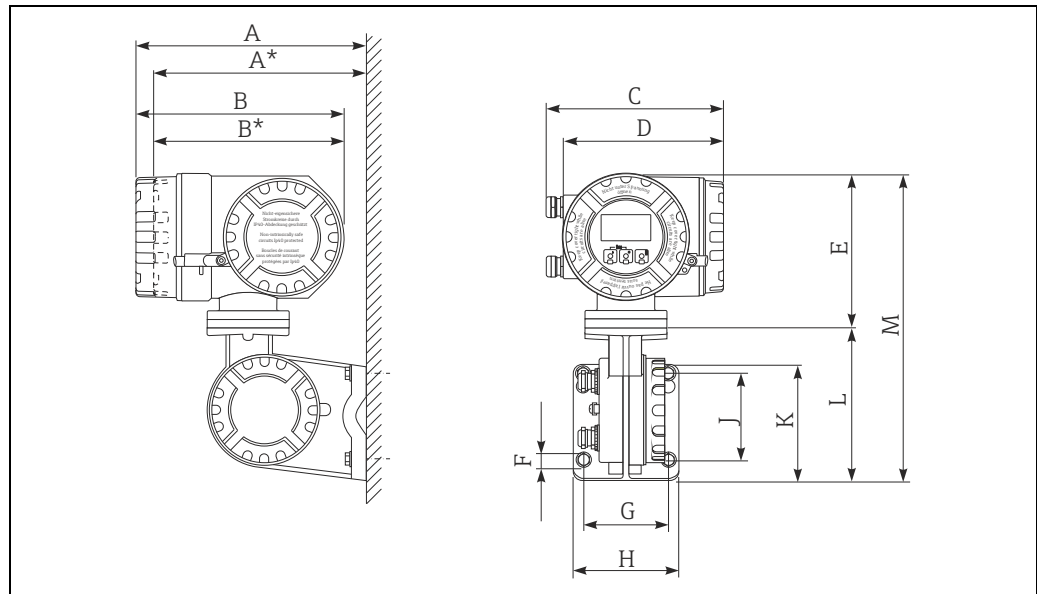

## Dimensions in SI units

A	A*	B	B*	C	D	E	F Ø	G	H	J	K	L	M
265	242	240	217	206	186	178	8.6 (M8)	100	130	100	144	170	348

\* Blind version (without local display)  
All dimensions in [mm]

## Dimensions in US units

A	A*	B	B*	C	D	E	F Ø	G	H	J	K	L	M
10.4	9.53	9.45	8.54	8.11	7.32	7.01	0,34 (M8)	3.94	5.12	3.94	5.67	6.69	13.7

\* Blind version (without local display)  
All dimensions in [inch]

Transmitter remote version, wall-mount housing (non hazardous area and II3G / zone 2)

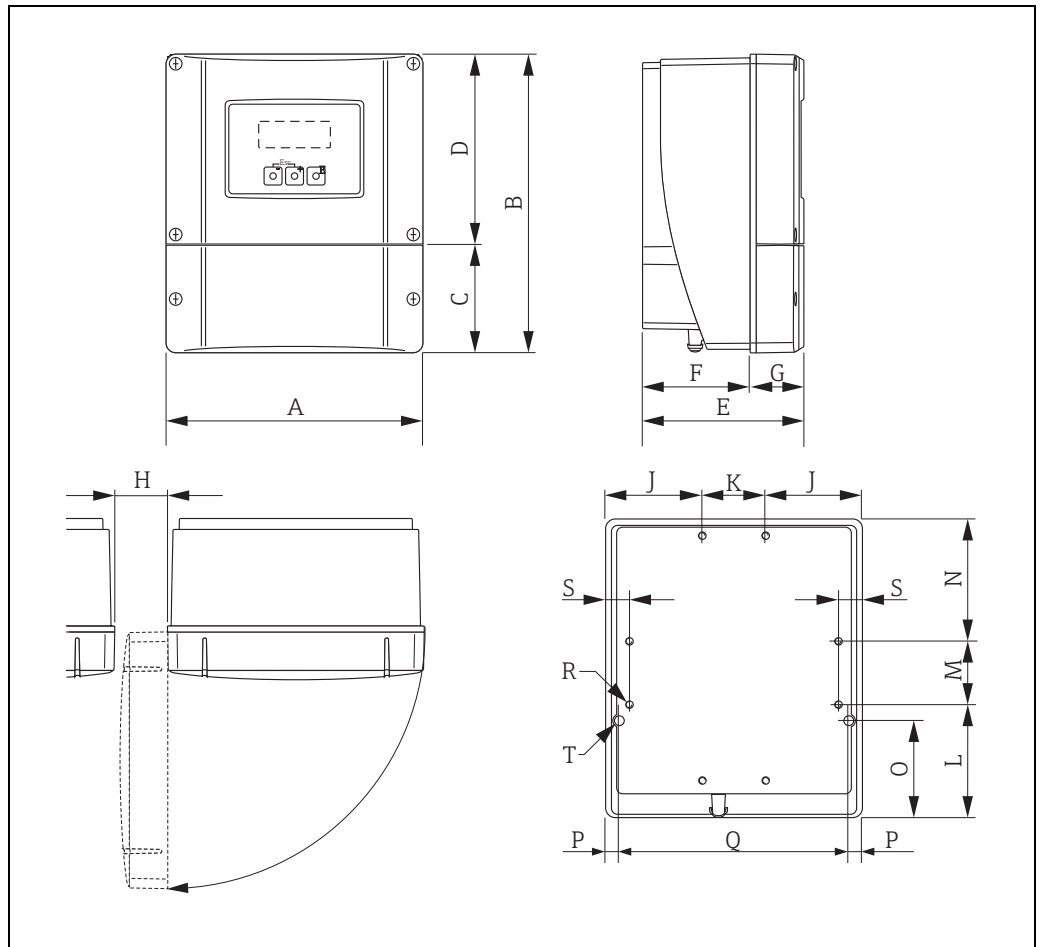

a0001150

Dimensions (SI units)

A	B	C	D	E	F	G	H	J	K
215	250	90.5	159.5	135	90	45	> 50	81	53
L	M	N	O	P	Q	R	S	T <sup>1)</sup>	
95	53	102	81.5	11.5	192	8 × M5	20	2 × Ø 6.5	

<sup>1)</sup> Securing screw for wall mounting: M6 (screw head max. 10.5 mm)

All dimensions in [mm]

Dimensions (US units)

A	B	C	D	E	F	G	H	J	K
8.46	9.84	3.56	6.27	5.31	3.54	1.77	> 1.97	3.18	2.08
L	M	N	O	P	Q	R	S	T <sup>1)</sup>	
3.74	2.08	4.01	3.20	0.45	7.55	8 × M5	0.79	2 × Ø 0.26	

<sup>1)</sup> Securing screw for wall mounting: M6 (screw head max. 0.41")

All dimensions in [inch]

## Sensor remote version, connection housing

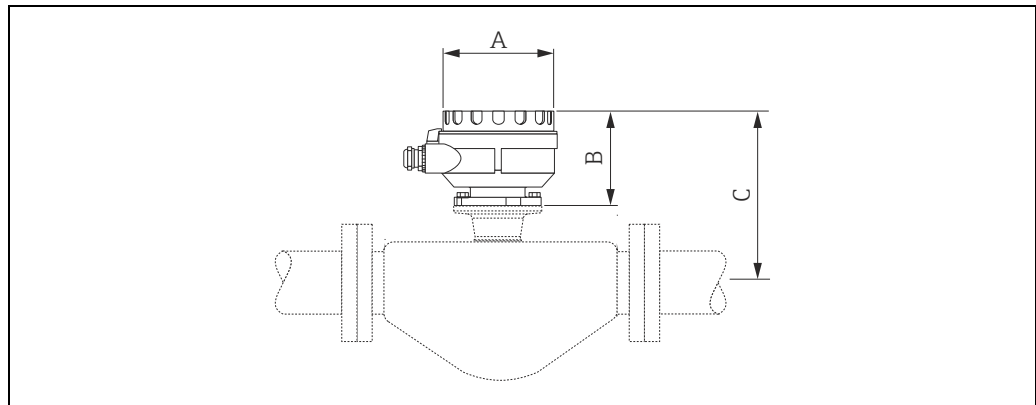

a0007637

## Dimensions in SI units

DN	A	B	C
8	129	102	166
15	129	102	168
25	129	102	173
40	129	102	179
50	129	102	195
80	129	102	224

All dimensions in [mm]

## Dimensions in US units

DN	A	B	C
3/8"	5.08	4.02	6.54
1/2"	5.08	4.02	6.61
1"	5.08	4.02	6.81
1 1/2"	5.08	4.02	7.05
2"	5.08	4.02	7.68
3"	5.08	4.02	8.82

All dimensions in [inch]

**Process connections in SI units**

Flange connections EN (DIN), ASME B16.5, JIS

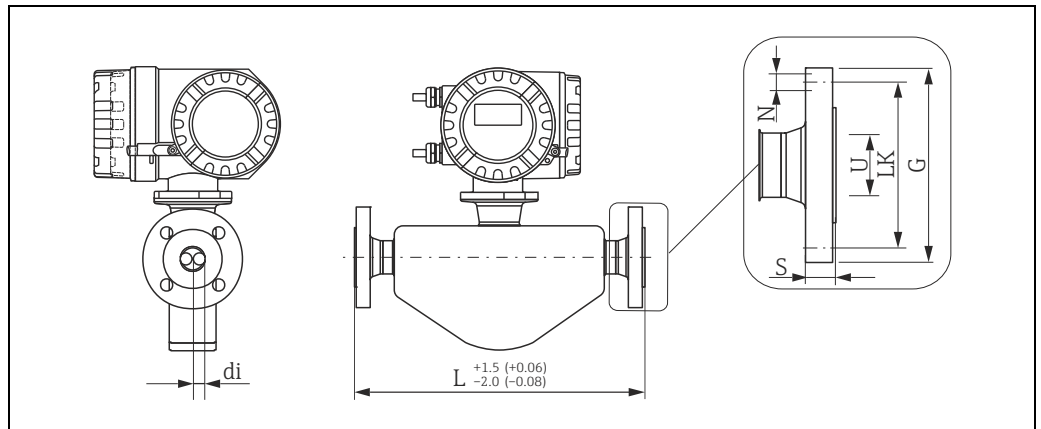

Dimension unit in mm (in)

A0021285

Flange connections EN (DIN)

**Flange according to EN 1092-1 (DIN 2501), PN 40:** 1.4404 (F316/F316L)  
 Order code for "Process connection", option D2S

**Flange with groove according to EN 1092-1 (DIN 2512N), PN 40:** 1.4404 (F316/F316L)  
 Order code for "Process connection", option D6S

Surface roughness (flange): EN 1092-1 Form B1 (DIN 2526 Form C), Ra 3.2 to 12.5  $\mu\text{m}$

DN	G	L	N	S	LK	U	di
8	95	232/510 <sup>2)</sup>	4 × Ø14	16	65	17.3	5.35
15	95	279/510 <sup>2)</sup>	4 × Ø14	16	65	17.3	8.30
25	115	329/600 <sup>2)</sup>	4 × Ø14	18	85	28.5	12.0
40	150	445	4 × Ø18	18	110	43.1	17.6
50	165	556/715 <sup>2)</sup>	4 × Ø18	20	125	54.5	26.0
80	200	611/915 <sup>2)</sup>	8 × Ø18	24	160	82.5	40.5

<sup>2)</sup> Installation length according to NAMUR recommendation NE 132: order code for "Process connection", option D2N (with groove D6N)  
 All dimensions in [mm]

**Flange according to EN 1092-1 (DIN 2501), PN 40 (with DN 25-flanges):** 1.4404 (F316/F316L)  
 Order code for "Process connection", option R2S

Surface roughness (flange): EN 1092-1 Form B1 (DIN 2526 Form C), Ra 3.2 to 12.5  $\mu\text{m}$

DN	G	L	N	S	LK	U	di
8	115	302	4 × Ø14	18	85	28.5	5.35
15	115	315	4 × Ø14	18	85	28.5	8.30

All dimensions in [mm]

**Flange according to EN 1092-1 (DIN 2501), PN 63: 1.4404 (F316/F316L)**

Order code for "Process connection", option D3S

**Flange with groove according to EN 1092-1 (DIN 2512N), PN 63: 1.4404 (F316/F316L)**

Order code for "Process connection", option D7S

Surface roughness (flange): EN 1092-1 Form B2 (DIN 2526 Form E), Ra 0.8 to 3.2 µm

DN	G	L	N	S	LK	U	di
50	180	565	4 × Ø22	26	135	54.5	26.0
80	215	646	8 × Ø22	28	170	81.7	40.5

All dimensions in [mm]

**Flange EN 1092-1 (DIN 2501), PN 100: 1.4404 (F316/F316L)**

Order code for "Process connection", option D4S

**Flange with groove according to EN 1092-1 (DIN 2512N), PN 100: 1.4404 (F316/F316L)**

Order code for "Process connection", option D8S

Surface roughness (flange): EN 1092-1 Form B2 (DIN 2526 Form E), Ra 0.8 to 3.2 µm

DN	G	L	N	S	LK	U	di
8	105	261	4 × Ø14	20	75	17.3	5.35
15	105	295	4 × Ø14	20	75	17.3	8.30
25	140	360	4 × Ø18	24	100	28.5	12.0
40	170	486	4 × Ø22	26	125	42.5	17.6
50	195	581	4 × Ø26	28	145	53.9	26.0
80	230	656	8 × Ø26	32	180	80.9	40.5

All dimensions in [mm]



## Flange connections ASME B16.5

<b>Flange according to ASME B16.5, Cl 150: 1.4404 (F316/F316L)</b>							
Order code for "Process connection", option AAS							
DN	G	L	N	S	LK	U	di
8	88.9	232	4 × Ø15.7	11.2	60.5	15.7	5.35
15	88.9	279	4 × Ø15.7	11.2	60.5	15.7	8.30
25	108.0	329	4 × Ø15.7	14.2	79.2	26.7	12.0
40	127.0	445	4 × Ø15.7	17.5	98.6	40.9	17.6
50	152.4	556	4 × Ø19.1	19.1	120.7	52.6	26.0
80	190.5	611	4 × Ø19.1	23.9	152.4	78.0	40.5

All dimensions in [mm]

<b>Flange according to ASME B16.5, Cl 300: 1.4404 (F316/F316L)</b>							
Order code for "Process connection", option ABS							
DN	G	L	N	S	LK	U	di
8	95.2	232	4 × Ø15.7	14.2	66.5	15.7	5.35
15	95.2	279	4 × Ø15.7	14.2	66.5	15.7	8.30
25	123.9	329	4 × Ø19.0	17.5	88.9	26.7	12.0
40	155.4	445	4 × Ø22.3	20.6	114.3	40.9	17.6
50	165.1	556	8 × Ø19.0	22.3	127.0	52.6	26.0
80	209.5	611	8 × Ø22.3	28.4	168.1	78.0	40.5

All dimensions in [mm]

<b>Flange according to ASME B16.5, Cl 600: 1.4404 (F316/F316L)</b>							
Order code for "Process connection", option ACS							
DN	G	L	N	S	LK	U	di
8	95.3	261	4 × Ø15.7	20.6	66.5	13.9	5.35
15	95.3	295	4 × Ø15.7	20.6	66.5	13.9	8.30
25	124.0	380	4 × Ø19.1	23.9	88.9	24.3	12.0
40	155.4	496	4 × Ø22.4	28.7	114.3	38.1	17.6
50	165.1	583	8 × Ø19.1	31.8	127.0	49.2	26.0
80	209.6	671	8 × Ø22.4	38.2	168.1	73.7	40.5

All dimensions in [mm]

## Flange connections JIS

<b>JIS B2220, flange, 10K: 1.4404 (F316/F316L)</b> Order code for "Process connection", option NDS							
DN	G	L	N	S	LK	U	di
50	155	556	4 × Ø19	16	120	50	26.0
80	185	603	8 × Ø19	18	150	80	40.5

All dimensions in [mm]

<b>JIS B2220, flange, 20K: 1.4404 (F316/F316L)</b> Order code for "Process connection", option NES							
DN	G	L	N	S	LK	U	di
8	95	232	4 × Ø15	14	70	15	5.35
15	95	279	4 × Ø15	14	70	15	8.30
25	125	329	4 × Ø19	16	90	25	12.0
40	140	445	4 × Ø19	18	105	40	17.6
50	155	556	8 × Ø19	18	120	50	26.0
80	200	603	8 × Ø23	22	160	80	40.5

All dimensions in [mm]

<b>JIS B2220, flange, 40K: 1.4404 (F316/F316L)</b> Order code for "Process connection", option NGS							
DN	G	L	N	S	LK	U	di
8	115	261	4 × Ø19	20	80	15	5.35
15	115	300	4 × Ø19	20	80	15	8.30
25	130	375	4 × Ø19	22	95	25	12.0
40	160	496	4 × Ø23	24	120	38	17.6
50	165	601	8 × Ø19	26	130	50	26.0
80	210	661	8 × Ø23	32	170	75	40.5

All dimensions in [mm]

<b>JIS B2220, flange, 63K: 1.4404 (F316/F316L)</b> Order code for "Process connection", option NHS							
DN	G	L	N	S	LK	U	di
8	120	282	4 × Ø19	23	85	12	5.35
15	120	315	4 × Ø19	23	85	12	8.30
25	140	383	4 × Ø23	27	100	22	12.0
40	175	515	4 × Ø25	32	130	35	17.6
50	185	616	8 × Ø23	34	145	48	26.0
80	230	686	8 × Ø25	40	185	73	40.5

All dimensions in [mm]

Tri-Clamp

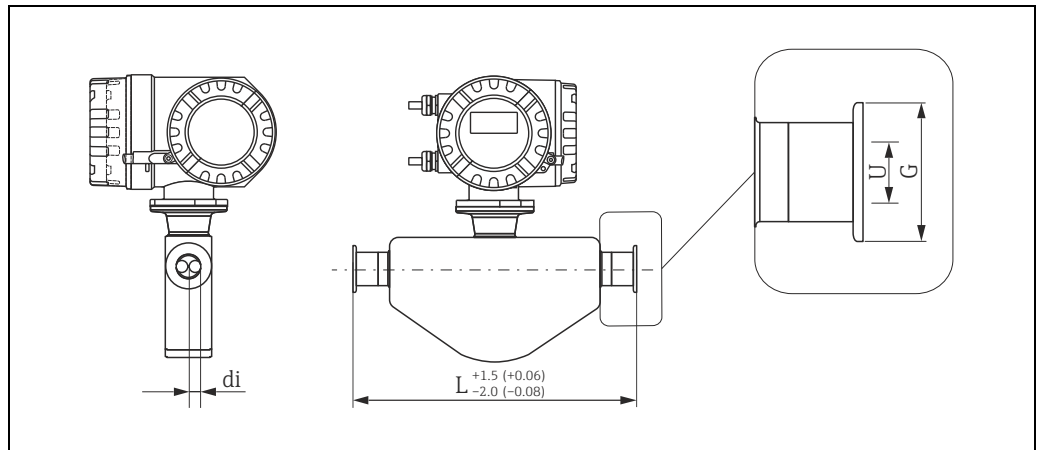

A0021287

Dimension in mm (in)

<b>1", 1½", 2" -Tri-Clamp: 1.4404 (316/316L)</b>					
Order code for "Process connection", option FTS					
DN	Clamp	G	L	U	di
8	1"	50.4	229	22.1	5.35
15	1"	50.4	273	22.1	8.30
25	1"	50.4	324	22.1	12.0
40	1½"	50.4	456	34.8	17.6
50	2"	63.9	562	47.5	26.0
80	3"	90.9	671	72.9	40.5

3A version,  $R_a \leq 0.8 \mu\text{m}$  (150 grit): order code for "Process connection", option FTA

3A version,  $R_a \leq 0.4 \mu\text{m}$  (240 grit): order code for "Process connection", option FTD

All dimensions in [mm]

<b>½"-Tri-Clamp: 1.4404 (316/316L)</b>					
Order code for "Process connection", option FUW					
DN	Clamp	G	L	U	di
8	½"	25.0	229	9.5	5.35
15	½"	25.0	273	9.5	8.30

3A version,  $R_a \leq 0.8 \mu\text{m}$  (150 grit): order code for "Process connection", option FUA

3A version,  $R_a \leq 0.4 \mu\text{m}$  (240 grit): order code for "Process connection", option FUD

All dimensions in [mm]

DIN 11851, thread, DIN11866 line A

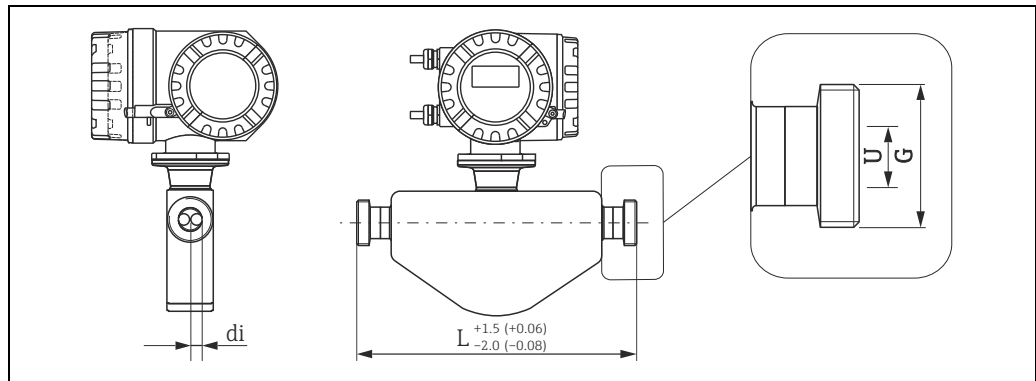

A0021288

Dimension in mm (in)

DIN 11851, thread, DIN11866 line A: 1.4404 (316/316L)				
Order code for "Process connection", option FMW				
DN	G	L	U	di
8	Rd 34 × 1/8"	229	16	5.35
15	Rd 34 × 1/8"	273	16	8.30
25	Rd 52 × 1/6"	324	26	12.0
40	Rd 65 × 1/6"	456	38	17.6
50	Rd 78 × 1/6"	562	50	26.0
80	Rd 110 × 1/4"	671	81	40.5

3A version, Ra ≤ 0.8 μm (150 grit): order code for "Process connection", option FMA  
All dimensions in [mm]

DIN 11864-1 Form A, thread, DIN11866 line A

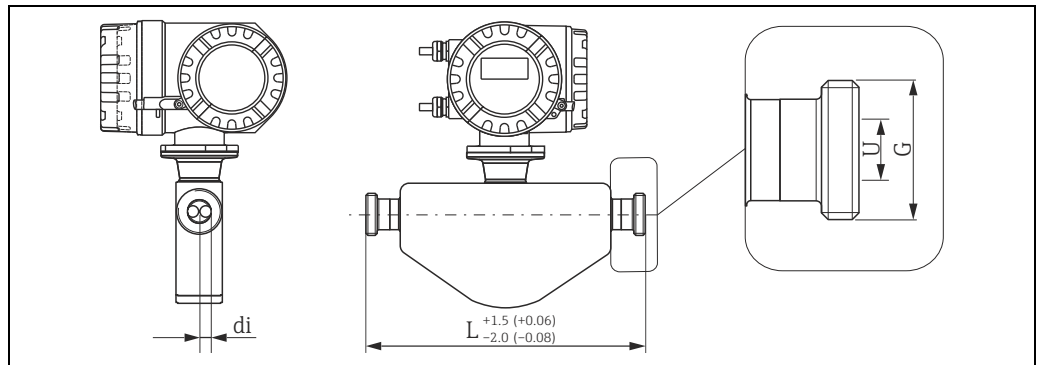

Dimension unit in mm (in)

DIN 11864-1 Form A, thread, DIN11866 line A: 1.4404 (316/316L)				
Order code for "Process connection", option FLW				
DN	G	L	U	di
8	Rd 28 × 1/8"	229	10	5.35
15	Rd 34 × 1/8"	273	16	8.30
25	Rd 52 × 1/6"	324	26	12.00
40	Rd 65 × 1/6"	456	38	17.60
50	Rd 78 × 1/6"	562	50	26.00
80	Rd 110 × 1/4"	671	81	40.5

3A version also available,  $Ra \leq 0.8 \mu\text{m}$  (150 grit): order code for "Process connection", option FLA  
 All dimensions in [mm]

## DIN 11864-2 Form A, flange, DIN11866 line A, flange with notch

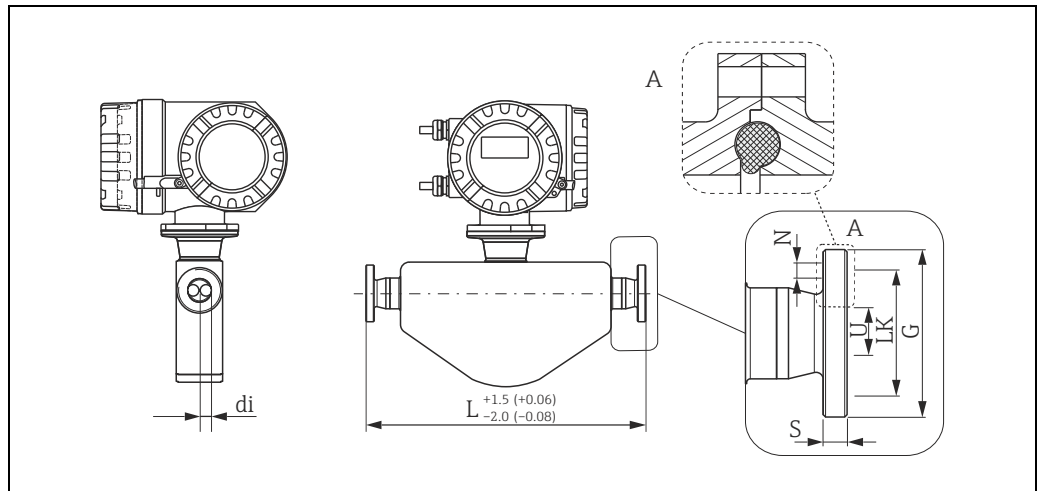

A0021294

Dimension unit in mm (in)

DIN 11864-2 Form A, flange, DIN11866 line A, flange with notch: 1.4404 (316/316L)							
Order code for "Process connection", option FKW							
DN	G	L	N	S	LK	U	di
8	54	249	4 × Ø9	10	37	10	5.35
15	59	293	4 × Ø9	10	42	16	8.30
25	70	344	4 × Ø9	10	53	26	12.0
40	82	456	4 × Ø9	10	65	38	17.6
50	94	562	4 × Ø9	10	77	50	26.0
80	133	671	8 × Ø11	12	112	81	40.5

3A version, Ra ≤ 0.8 µm (150 grit): order code for "Process connection", option FKA  
 All dimensions in [mm]

ISO 2853, thread, ISO2037

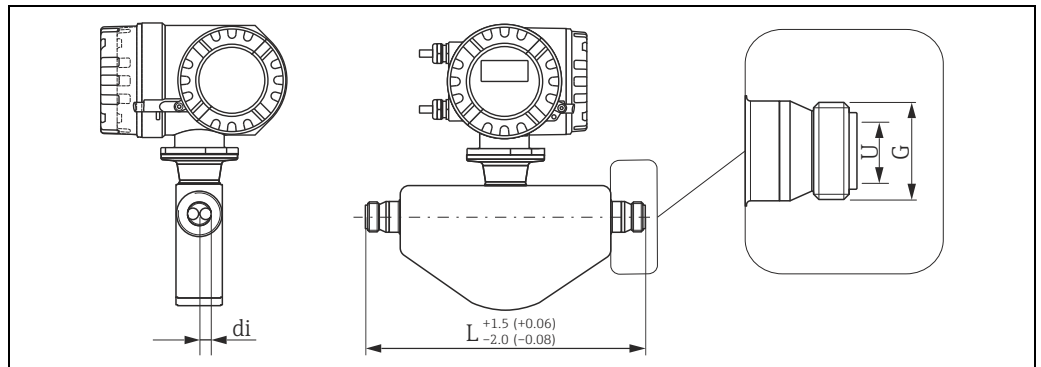

Dimension in mm (in)

A0021290

**ISO 2853, thread, ISO2037: 1.4404 (316/316L)**

Order code for "Process connection", option FJW

DN	G <sup>1)</sup>	L	U	di
8	37.13	229	22.6	5.35
15	37.13	273	22.6	8.30
25	37.13	324	22.6	12.0
40	50.68	456	35.6	17.6
50	64.16	562	48.6	26.0
80	91.19	671	72.9	40.5

<sup>1)</sup> Max. thread diameter to ISO 2853 Annex A

3A version, Ra ≤ 0.8 μm (150 grit): order code for "Process connection", option FJA

All dimensions in [mm]

SMS 1145, thread

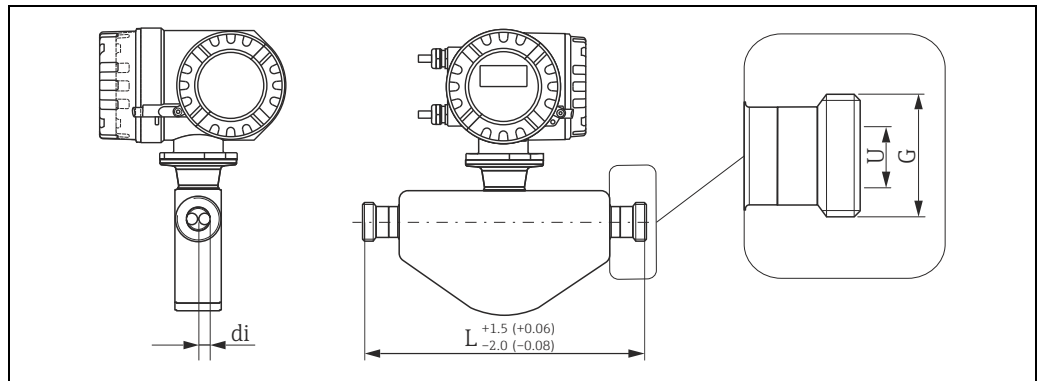

A0021291

Dimension unit in mm (in)

**SMS 1145, thread: 1.4404 (316/316L)**  
 Order code for "Process connection", option FSW

DN	G	L	U	di
8	Rd 40 × 1/6"	229	22.5	5.35
15	Rd 40 × 1/6"	273	22.5	8.30
25	Rd 40 × 1/6"	324	22.5	12.0
40	Rd 60 × 1/6"	456	35.5	17.6
50	Rd 70 × 1/6"	562	48.5	26.0
80	Rd 98 × 1/6"	671	72.9	40.5

3A version, Ra ≤ 0.8 μm (150 grit): order code for "Process connection", option FSA  
 All dimensions in [mm]

VCO connections

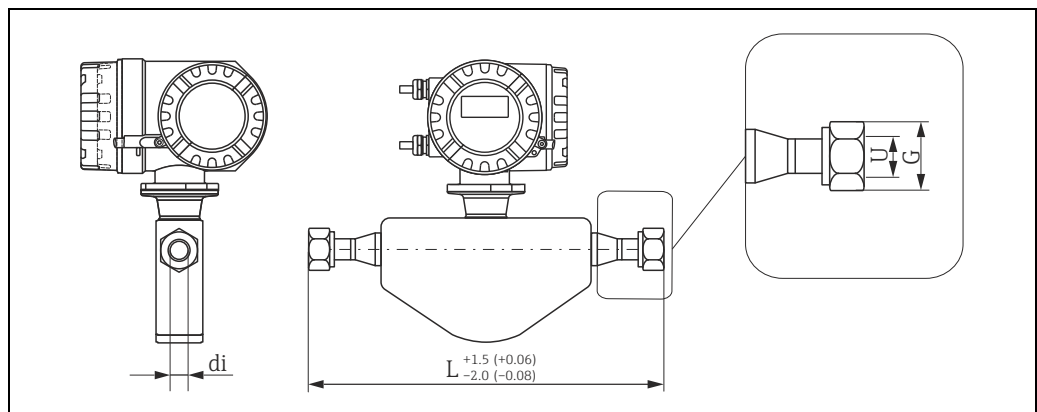

A0021286

Dimension unit in mm (in)

**VCO connections: 1.4404 (316/316L)**

DN	G	Order code for "Process connection", option	L	U	di
8	1" AF	CVS	252	10.2	5.35
15	1 1/2" AF	CWS	305	15.7	8.30

All dimensions in [mm]



**Process connections in US units**

*Flange connections ASME B16.5*

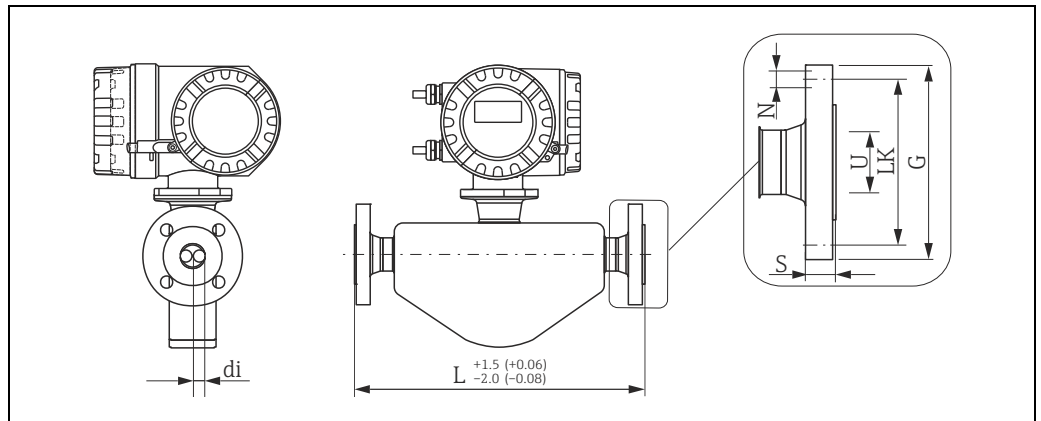

Dimension unit in mm (in)

A0021285

**Flange according to ASME B16.5, CI 150: 1.4404 (316/316L)**  
 Order code for "Process connection", option AAS

DN	G	L	N	S	LK	U	di
3/8"	3.50	9.13	4 × Ø0.62	0.44	2.38	0.62	0.21
1/2"	3.50	10.98	4 × Ø0.62	0.44	2.38	0.62	0.33
1"	4.25	12.95	4 × Ø0.62	0.56	3.12	1.05	0.47
1 1/2"	5.00	17.52	4 × Ø0.62	0.69	3.88	1.61	0.69
2"	6.00	21.89	4 × Ø0.75	0.75	4.75	2.07	1.02
3"	7.50	24.06	4 × Ø0.75	0.94	6.00	3.07	1.59

All dimensions in [inch]

**Flange according to ASME B16.5, CI 300: 1.4404 (316/316L)**  
 Order code for "Process connection", option ABS

DN	G	L	N	S	LK	U	di
3/8"	3.75	9.13	4 × Ø0.62	0.56	2.62	0.62	0.21
1/2"	3.75	10.98	4 × Ø0.62	0.56	2.62	0.62	0.33
1"	4.88	12.95	4 × Ø0.75	0.69	3.50	1.05	0.47
1 1/2"	6.12	17.52	4 × Ø0.88	0.81	4.50	1.61	0.69
2"	6.50	21.89	4 × Ø0.75	0.88	5.00	2.07	1.02
3"	8.25	24.06	8 × Ø0.88	1.12	6.62	3.07	1.59

All dimensions in [inch]

Flange according to ASME B16.5, Cl 600: 1.4404 (316/316L)							
Order code for "Process connection", option ACS							
DN	G	L	N	S	LK	U	di
3/8"	3.75	10.28	4 × Ø0.62	0.81	2.62	0.55	0.21
1/2"	3.75	11.61	4 × Ø0.62	0.81	2.62	0.55	0.33
1"	4.88	14.96	4 × Ø0.75	0.94	3.50	0.96	0.47
1½"	6.12	19.53	4 × Ø0.88	1.13	4.50	1.50	0.69
2"	6.50	22.95	4 × Ø0.75	1.25	5.00	1.94	1.02
3"	8.27	26.42	8 × Ø0.88	1.50	6.63	2.90	1.59

All dimensions in [inch]

Tri-Clamp

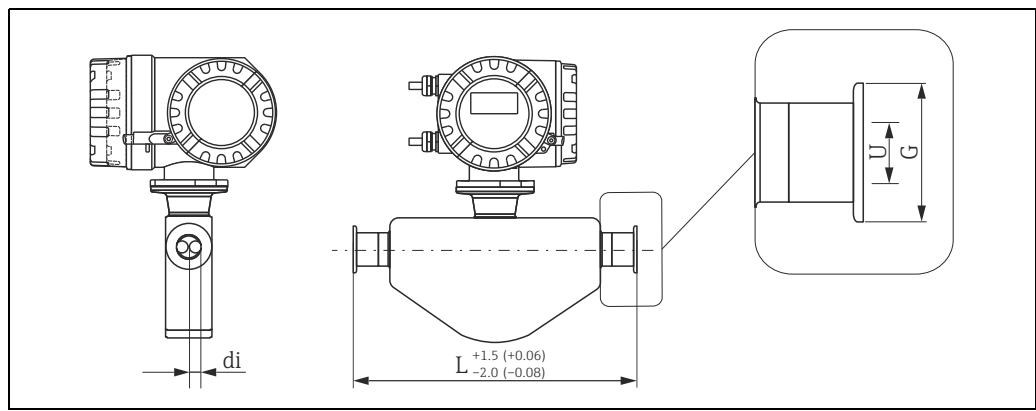

Dimension in mm (in)

1", 1½", 2" -Tri-Clamp: 1.4404 (316/316L)					
Order code for "Process connection", option FTS					
DN	Clamp	G	L	U	di
3/8"	1"	1.98	9.02	0.87	0.21
1/2"	1"	1.98	10.75	0.87	0.33
1"	1"	1.98	12.76	0.87	0.47
1½"	1½"	1.98	17.95	1.37	0.69
2"	2"	2.52	22.13	1.87	1.02
3"	3"	3.58	26.42	2.87	1.59

3A version, Ra ≤ 32 µin (150 grit): order code for "Process connection", option FTA

3A version, Ra ≤ 16 µin (240 grit): order code for "Process connection", option FTD

All dimensions in [inch]

½"-Tri-Clamp: 1.4404 (316/316L)					
Order code for "Process connection", option FUW					
DN	Clamp	G	L	U	di
3/8"	½"	0.98	9.02	0.37	0.21
1/2"	½"	0.98	10.75	0.37	0.33

3A version, Ra ≤ 32 µin (150 grit): order code for "Process connection", option FUA

3A version, Ra ≤ 16 µin (240 grit): order code for "Process connection", option FUD

All dimensions in [inch]

SMS 1145, thread

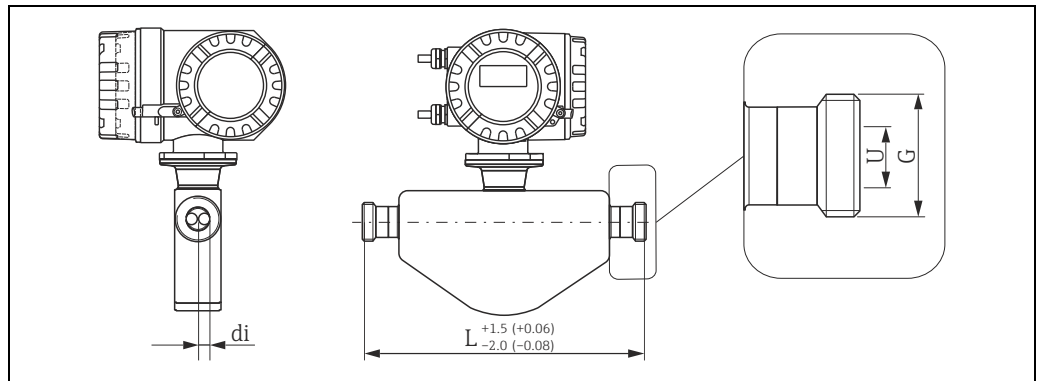

A0021291

Dimension unit in mm (in)

**SMS 1145, thread: 1.4404 (316/316L)**

Order code for "Process connection", option FSW

DN	G	L	U	di
3/8"	Rd 40 × 1/6"	9.02	0.89	0.21
1/2"	Rd 40 × 1/6"	10.75	0.89	0.33
1"	Rd 40 × 1/6"	12.76	0.89	0.47
1 1/2"	Rd 60 × 1/6"	17.95	1.40	0.69
2"	Rd 70 × 1/6"	22.13	1.91	1.02
3"	Rd 98 × 1/6"	26.42	2.87	1.59

3A version, Ra ≤ 16 µin (240 grit): order code for "Process connection", option FSA

All dimensions in [inch]

VCO connections

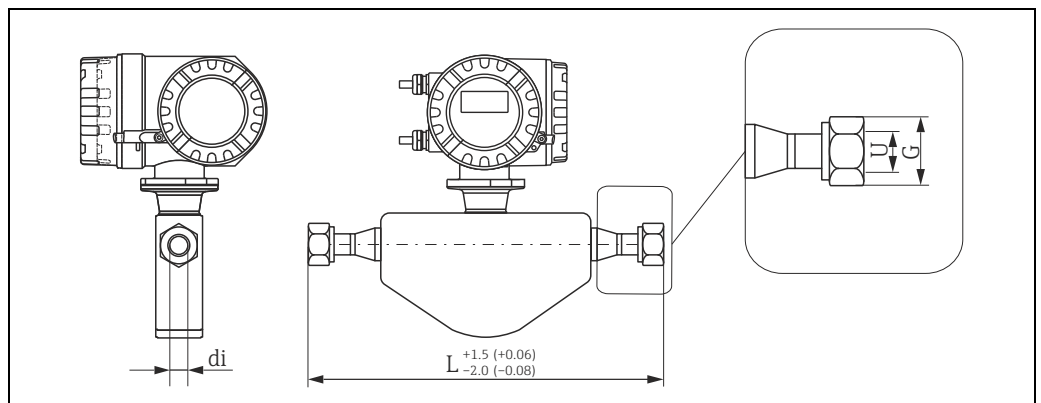

A0021286

Dimension unit in mm (in)

**VCO connections: 1.4404 (316/316L)**

DN	G	Order code for "Process connection", option	L	U	di
3/8"	1" AF	CVS	9.92	0.40	0.21
1/2"	1 1/2" AF	CWS	12.01	0.62	0.33

All dimensions in [inch]

**Weight**

- Compact version: see table below
- Remote version
  - Sensor: see table below
  - Wall-mount housing: 5 kg (11 lb)

**Weight in SI units**

DN [mm]	8	15	25	40	50	80
Compact version	8	8	10	15	22	31
Remote version (sensor)	6	6	8	13	20	29

All values (weight) refer to devices with EN/DIN PN 40 flanges.  
Weight information in [kg]

**Weight in US units**

DN [inch]	3/8"	1/2"	1"	1 1/2"	2"	3"
Compact version	18	18	22	33	49	69
Remote version (sensor)	13	13	18	29	44	64

All values (weight) refer to devices with EN/DIN PN 40 flanges.  
Weight information in [lb]

**Materials****Transmitter housing**

Compact version

- Powder coated die-cast aluminum
- Window material: glass

Remote version

- Remote field housing: powder-coated die-cast aluminum
- Wall-mount housing: powder coated die-cast aluminum
- Window material: glass

**Sensor housing / containment**

- Acid and alkali-resistant outer surface
- Stainless steel 1.4301 (304)

**Connection housing, sensor (remote version)**

- Powder coated die-cast aluminum

**Process connections**

- Stainless steel 1.4404 (F316/F316L)
  - Flanges according to EN 1092-1 (DIN 2501)
  - Flanges according to ASME B16.5
  - Flanges to JIS B2220
- Stainless steel 1.4404 (316/316L)
  - Flange DIN 11864-2 Form A
  - Threads DIN 11851, SMS 1145, ISO 2853, DIN 11864-1 Form A
  - Tri-Clamp
  - VCO connections

**Measuring tubes**

- Stainless steel 1.4539 (904L); manifold: 1.4404 (316/316L)
- Finish quality: Ra<sub>max</sub> ≤ 0.8 µm/150 grit (30 µin/150 grit)

**Seals**

Welded process connections without internal seals

**Process connections**

**Welded process connections**

- Flanges: according to EN 1092-1 (DIN 2501), Namur lengths in accordance with NE 132, according to ASME B16.5, JIS B2220
- VCO connections
- Sanitary connections: Tri-Clamp, threads (DIN 11851, SMS 1145, ISO 2853, DIN 11864-1), flange (DIN 11864-2 Form A)

## Operability

**Local operation**

**Display elements**

- Liquid-crystal display: backlit, two lines (Promass 80) or four lines (Promass 83) with 16 characters per line
- Selectable display of different measured values and status variables
- At ambient temperatures below -20 °C (-4 °F) the readability of the display may be impaired.

**Operating elements**

**Promass 80**

- Local operation with three keys (◀ ⊕ ▶)
- Quick Setup menus for straightforward commissioning

**Promass 83**

- Local operation with three optical keys (◀ ⊕ ▶)
- Application-specific Quick Setup menus for straightforward commissioning

**Language group**

Language groups available for operation in different countries:

Valid until software version 3.01.xx			
Order code	Option		Inhalt
Power Supply; Display	WEA	Western Europe and America	English, German, Spanish, Italian, French, Dutch and Portuguese
	EES	Eastern Europe and Scandinavia	English, Russian, Polish, Norwegian, Finnish, Swedish and Czech
	SEA	South and East Asia	English, Japanese, Indonesian
	only Promass 83		
	CN	China	English, Chinese

Valid as of software version 3.07.xx (only Promass 83)		
Order code	Option	Inhalt
Power Supply; Display	P, Q	English, German, Spanish, Italian, French
	R, S	English, Russian, Portuguese, Dutch, Czech
	T, U	English, Japanese, Swedish, Norwegian, Finnish
	4, 5	English, Chinese, Indonesian, Polish

You can change the language group via the operating program "FieldCare".

**Remote operation**

**Promass 80**

Remote operation via HART, PROFIBUS PA

**Promass 83**

Remote operation via HART, PROFIBUS DP/PA, FOUNDATION fieldbus, Modbus RS485

## Certificates and approvals

<b>CE mark</b>	The measuring system is in conformity with the statutory requirements of the EC Directives. Endress+Hauser confirms successful testing of the device by affixing to it the CE mark.
<b>C-Tick symbol</b>	The measuring system complies with the EMC requirements of the "Australian Communications and Media Authority (ACMA)"
<b>Ex approval</b>	Information about currently available Ex versions (ATEX, FM, CSA, IECEx, NEPSI etc.) can be supplied by your Endress+Hauser Sales Center on request. All information relevant to explosion protection is available in separate Ex documents that you can order as necessary.
<b>Hygienic compatibility</b>	3A approval
<b>Functional safety</b>	SIL-2: accordance IEC 61508/IEC 61511-1 (FDIS) "4–20 mA" - output according to the following options in the order characteristic for "Input/Output": Promass 80: A, D, S, T, 8 Promass 83: A, B, C, D, E, L, M, R, S, T, U, W, 0, 2, 3, 4, 5, 6 See also "Terminal assignment" → 9
<b>HART certification</b>	The flowmeter has successfully passed all the test procedures carried out and is certified and registered by the HCF (Hart Communication Foundation). The device thus meets all the requirements of the following specifications: <ul style="list-style-type: none"> <li>▪ Certified in accordance with HART Revisions 5 and 7 (device certification number: available on request)</li> <li>▪ The measuring device can also be operated with certified devices of other manufacturers (interoperability).</li> </ul>
<b>FOUNDATION Fieldbus certification</b>	The flow device has successfully passed all the test procedures carried out and is certified and registered by the Fieldbus Foundation. The device thus meets all the requirements of the following specifications: <ul style="list-style-type: none"> <li>▪ Certified to FOUNDATION Fieldbus Specification</li> <li>▪ The device meets all the specifications of the FOUNDATION Fieldbus H1.</li> <li>▪ Interoperability Test Kit (ITK), revision status 5.01 (device certification number: on request)</li> <li>▪ The device can also be operated with certified devices of other manufacturers</li> <li>▪ Physical Layer Conformance Test of the Fieldbus Foundation</li> </ul>
<b>PROFIBUS DP/PA certification</b>	The flow device has successfully passed all the test procedures carried out and is certified and registered by the PNO (PROFIBUS User Organization). The device thus meets all the requirements of the following specifications: <ul style="list-style-type: none"> <li>▪ Certified in accordance with PROFIBUS Profile Version 3.0 (device certification number: available on request)</li> <li>▪ The device can also be operated with certified devices of other manufacturers (interoperability)</li> </ul>
<b>Modbus RS485 certification</b>	The measuring device meets all the requirements of the Modbus RS485/TCP conformity test and has the "Modbus RS485/TCP Conformance Test Policy, Version 2.0". The measuring device has successfully passed all the test procedures carried out and is certified by the "Modbus RS485/TCP Conformance Test Laboratory" of the University of Michigan.

- Pressure Equipment Directive** The measuring devices can be ordered with or without PED (Pressure Equipment Directive). If a device with PED is required, this must be ordered explicitly. For devices with nominal diameters less than or equal to DN 25 (1"), this is neither possible nor necessary.
- With the identification PED/G1/III on the sensor nameplate, Endress+Hauser confirms conformity with the "Basic safety requirements" of Appendix I of the Pressure Equipment Directive 97/23/EC.
  - Devices with this identification (with PED) are suitable for the following types of fluid:
    - Fluids of Group 1 and 2 with a steam pressure greater than, or smaller and equal to 0.5 bar (7.3 psi)
    - Unstable gases
  - Devices without this identification (without PED) are designed and manufactured according to good engineering practice. They correspond to the requirements of Art. 3, Section 3 of the Pressure Equipment Directive 97/23/EC. Their application is illustrated in Diagrams 6 to 9 in Appendix II of the Pressure Equipment Directive 97/23/EC.

---

**Other standards and guidelines**

- EN 60529  
Degrees of protection by housing (IP code)
- EN 61010-1  
Protection Measures for Electrical Equipment for Measurement, Control, Regulation and Laboratory Procedures.
- IEC/EN 61326  
"Emission in accordance with Class A requirements". Electromagnetic compatibility (EMC requirements)
- NAMUR NE 21  
Electromagnetic compatibility (EMC) of industrial process and laboratory control equipment.
- NAMUR NE 43  
Standardization of the signal level for the breakdown information of digital transmitters with analog output signal.
- NAMUR NE 53  
Software of field devices and signal-processing devices with digital electronics
- NAMUR NE 132  
Coriolis mass meter

## Ordering Information

Detailed ordering information is available from the following sources:

- In the Product Configurator on the Endress+Hauser website: [www.endress.com](http://www.endress.com) → Select country → Instruments → Select device → Product page function: Configure this product
- From your Endress+Hauser Sales Center: [www.endress.com/worldwide](http://www.endress.com/worldwide)



Note!

**Product Configurator - the tool for individual product configuration**

- Up-to-the-minute configuration data
- Depending on the device: Direct input of measuring point-specific information such as measuring range or operating language
- Automatic verification of exclusion criteria
- Automatic creation of the order code and its breakdown in PDF or Excel output format
- Ability to order directly in the Endress+Hauser Online Shop

## Accessories

Various accessories, which can be ordered with the device or subsequently from Endress+Hauser, are available for the device. Detailed information on the order code in question is available from your local Endress+Hauser sales center or on the product page of the Endress+Hauser website: [www.endress.com](http://www.endress.com).

### Device-specific accessories

#### For the Transmitter

Accessories	Description
Transmitter	Transmitter for replacement or for stock. Use the order code to define the following specifications: <ul style="list-style-type: none"> <li>- Approvals</li> <li>- Degree of protection / version</li> <li>- Cable entries,</li> <li>- Display / power supply / operation</li> <li>- Software</li> <li>- Outputs / inputs</li> </ul>
Inputs/outputs for Proline Promass 83 HART	Conversion kit with appropriate plug-in point modules for converting the input/output configuration in place to date to a new version.
Software packages for Proline Promass 83	Software add-ons on F-Chip, can be ordered individually: <ul style="list-style-type: none"> <li>- Advanced diagnostics</li> <li>- Batching functions</li> <li>- Concentration measurement</li> </ul>
Mounting set for transmitter	Mounting set for wall-mount housing (remote version). Suitable for: <ul style="list-style-type: none"> <li>- Wall mounting</li> <li>- Pipe mounting</li> <li>- Installation in control panel</li> </ul> Mounting set for aluminum field housing: Suitable for pipe mounting (3/4" to 3")

#### For the Sensor

Accessories	Description
Heating jacket	Is used to stabilize the temperature of the fluids in the sensor. Water, water vapor and other non-corrosive liquids are permitted for use as fluids. If using oil as a heating medium, please consult with Endress+Hauser. Heating jackets cannot be used with sensors fitted with a rupture disk.  For details, see Operating Instructions BA00099D

### Communication-specific accessories

Accessories	Description
HART Communicator Field Xpert handheld terminal	Handheld terminal for remote parameterization and for obtaining measured values via the current output HART (4 to 20 mA).  Contact your Endress+Hauser representative for more information.
Commubox FXA195 HART	The Commubox FXA195 connects intrinsically safe smart transmitters with the HART protocol with the USB port of a personal computer. This enables remote operation of the transmitter with operating software (e.g. FieldCare). Power is supplied to the Commubox via the USB port.



## Service-specific accessories

Accessories	Description
Applicator	<p>Software for selecting and sizing Endress+Hauser measuring devices:</p> <ul style="list-style-type: none"> <li>▪ Calculation of all the necessary data for identifying the optimum flowmeter: e.g. nominal diameter, pressure loss, accuracy or process connections</li> <li>▪ Graphic illustration of the calculation results</li> </ul> <p>Administration, documentation and access to all project-related data and parameters over the entire life cycle of a project.</p> <p>Applicator is available:</p> <ul style="list-style-type: none"> <li>▪ Via the Internet: <a href="https://wapps.endress.com/applicator">https://wapps.endress.com/applicator</a></li> <li>▪ On CD-ROM for local PC installation</li> </ul>
W@M	<p>Life cycle management for your plant.</p> <p>W@M supports you with a wide range of software applications over the entire process: from planning and procurement, to the installation, commissioning and operation of the measuring devices. All the relevant device information, such as the device status, spare parts and device-specific documentation, is available for every device over the entire life cycle. The application already contains the data of your Endress+Hauser device. Endress+Hauser also takes care of maintaining and updating the data records.</p> <p>W@M is available:</p> <ul style="list-style-type: none"> <li>▪ Via the Internet: <a href="http://www.endress.com/lifecyclemanagement">www.endress.com/lifecyclemanagement</a></li> <li>▪ On CD-ROM for local PC installation</li> </ul>
Fieldcheck	<p>Tester/simulator for testing flowmeters in the field.</p> <p>When used in conjunction with the "FieldCare" software package, test results can be imported into a database, printed and used for official certification. Contact your Endress+Hauser representative for more information.</p>
FieldCare	<p>FieldCare is Endress+Hauser's FDT-based plant asset management tool and allows the configuration and diagnosis of intelligent field devices. By using status information, you also have a simple but effective tool for monitoring devices. The Proline flowmeters are accessed via a service interface or via the service interface FXA193.</p>
FXA193	<p>Service interface from the measuring device to the PC for operation via FieldCare.</p>

## System components

Accessories	Description
Memograph M graphic display recorder	<p>The Memograph M graphic display recorder provides information on all the relevant process variables. Measured values are recorded correctly, limit values are monitored and measuring points analyzed. The data are stored in the 256 MB internal memory and also on a DSD card or USB stick. Memograph M boasts a modular design, intuitive operation and a comprehensive security concept. The ReadWin® 2000 PC software is part of the standard package and is used for configuring, visualizing and archiving the data captured. The mathematics channels which are optionally available enable continuous monitoring of specific power consumption, boiler efficiency and other parameters which are important for efficient energy management.</p>

## Documentation

- Flow measuring technology (FA005D)
- Technical Information
  - Promass 80A, 83A (T00054D)
  - Promass 80F, 83F (TI00101D)
  - Promass 80H, 83H (TI00074D)
  - Promass 80I, 83I (TI00075D)
  - Promass 80P, 83P (TI00078D)
  - Promass 80S, 83S (TI00076D)
- Operating Instructions/Description of Device Functions
  - Promass 80 HART (BA00057D/BA00058D)
  - Promass 80 PROFIBUS PA (BA00072D/BA00073D)
  - Promass 83 HART (BA00059D/BA00060D)
  - Promass 83 FOUNDATION Fieldbus (BA00065D/BA00066D)
  - Promass 83 PROFIBUS DP/PA(BA00063D/BA00064D)
  - Promass 83 Modbus RS485 (BA00107D/BA00108D)
- Supplementary documentation on Ex-ratings: ATEX, FM, CSA, IECEx NEPSI
- Functional safety manual Promass 80, 83 (SD00077D)

## Registered trademarks

TRI-CLAMP®

Registered trademark of Ladish & Co., Inc., Kenosha, WI, USA

HART®

Registered trademark of HART Communication Foundation, Austin, TX, USA

PROFIBUS®

Registered trademark of the PROFIBUS User Organization, Karlsruhe, Germany

FOUNDATION™ Fieldbus

Registered trademark of the Fieldbus FOUNDATION, Austin, USA

Modbus®

Registered trademark of the SCHNEIDER AUTOMATION, INC.

Applicator®, FieldCare®, Fieldcheck®, HistoROM™, F-CHIP®, S-DAT®, T-DAT™

Registered or registration-pending trademarks of the Endress+Hauser Group



[www.addresses.endress.com](http://www.addresses.endress.com)

---