

Special Documentation

Soliphant M with electronic insert FEM57 + Nivotester FTL325P

Functional Safety Manual

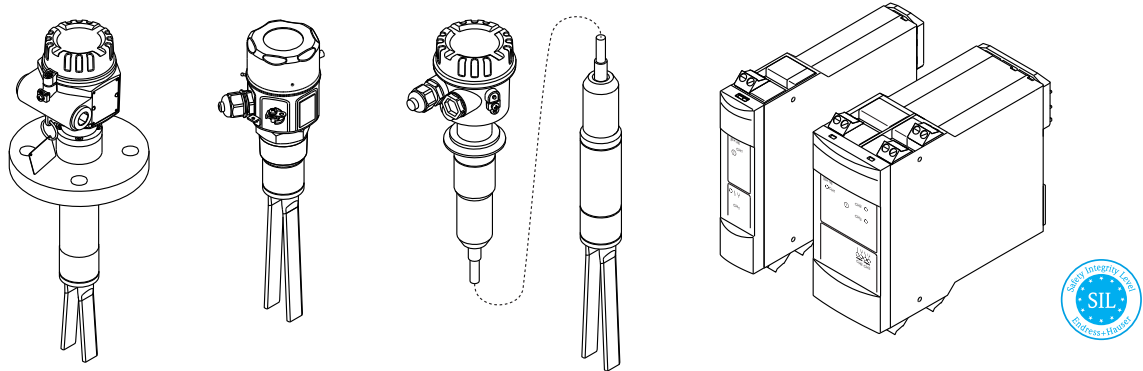

Point level measuring system

Table of contents

Declaration of conformity	3
General	5
Other safety-related characteristic values	5
Useful lifetime of electrical components	12
Certificate	13
Document information	14
Document function	14
Symbols used	14
Supplementary device documentation	15
Permitted devices types	16
SIL label on the nameplate	16
Safety function	17
Definition of the safety function	17
Restrictions for use in safety-related applications	17
Use in safety instrumented systems	19
Device behavior during operation	19
Device configuration for safety-related applications	19
Proof-testing	22
Life cycle	27
Requirements for personnel	27
Installation	27
Operation	27
Maintenance	27
Repair	27
Modification	28
Decommissioning	28
Appendix	29
Structure of the measuring system	29
Commissioning or proof test report	30
Further information	30
Version history	31

Declaration of conformity

SIL_00072_01.15

Endress+Hauser 
People for Process Automation

SIL-Declaration of Conformity

Functional Safety according to IEC 61508
Supplement 1 / NE130 Form B.1 and IGR 49-02-15 Datasheet 1

Endress+Hauser GmbH+Co. KG, Hauptstraße 1, 79689 Maulburg

being the manufacturer, declares that the product stated below

**Soliphant M with electronic insert FEM57
(+ Nivotester FTL325P)**

(Serial number XXXXXXXXXXX)

is suitable for the use in safety-instrumented systems according to IEC61508, if the safety instructions and following parameters are observed.

This declaration of conformity is only valid for the customer listed in the cover letter of the responsible Endress+Hauser sales center and for the listed products in delivery status.

Maulburg, 4-November-2015
Endress+Hauser GmbH+Co. KG

i. V. 
Dr. Arno Götz
Dept. Manager Product Safety
Research & Development

i. V. 
Dr. Dietmar Frühauf
Dept. Manager Level Switches
Research & Development

1/2

A0025622

SIL_00072_01.15

General			
Device designation and permissible types	Soliphant M with electronic insert FEM57 (+ Nivotester FTL325P)		
Safety-related output signal	Relay		
Fault current	-		
Process variable/function	Level switch for solids		
Safety function(s)	Overfill protection or operating maximum		
Device type acc. to IEC 61508-2	<input type="checkbox"/> Typ A	<input checked="" type="checkbox"/> Typ B	
Operating mode	<input checked="" type="checkbox"/> Low Demand Mode	<input type="checkbox"/> High Demand or Continuous Mode	
Valid Hardware-Version	FEM57 as of 01.01, FTL325P as of 02.00		
Valid Software-Version	FEM57 as of 01.00.01, FTL325P without SW		
Safety manual	SD00207F		
Type of evaluation (check only <u>one</u> box)	<input checked="" type="checkbox"/>	Complete HW/SW evaluation parallel to development incl. FMEDA and change request acc. to IEC 61508-2, 3	
	<input type="checkbox"/>	Evaluation of "Proven-in-use" performance for HW/SW incl. FMEDA and change request acc. to IEC 61508-2, 3	
	<input type="checkbox"/>	Evaluation of HW/SW field data to verify „prior use“ acc. to IEC 61511	
	<input type="checkbox"/>	Evaluation by FMEDA acc. to IEC61508-2 for devices w/o software	
Evaluation through – report no.	TÜV Rheinland, Report No 968/FSP 1148.00/15		
Test documents	Development documents	Test reports	Data sheets
SIL - Integrity			
Systematic safety integrity		<input checked="" type="checkbox"/> SIL 2 capable	<input type="checkbox"/> SIL 3 capable
Hardware safety integrity	Single channel use (HFT = 0)	<input checked="" type="checkbox"/> SIL 2 capable	<input type="checkbox"/> SIL 3 capable
	Multi channel use (HFT ≥1)	<input checked="" type="checkbox"/> SIL 2 capable	<input checked="" type="checkbox"/> SIL 3 capable
FMEDA ^{*3}			
Safety function	MAX		
$PF_{avg} T_1 = 1 \text{ year}$	$2,83 \times 10^{-4}$		
$\lambda_{DU}^{*1)}$	65 FIT		
$\lambda_{DU}^{*1)}$	40 FIT		
$\lambda_{SU}^{*1)}$	817 FIT		
$\lambda_{SD}^{*1)}$	157 FIT		
SFF - Safe Failure Fraction	94 %		
PTC ^{*2)}	63 97 % ^{*4}		
$\lambda_{total}^{*1)}$	1079 FIT		
Diagnostic test interval	≤ 60 s		
Fault reaction time	≤ 3 s		
Comments			
³ This information is based on the variant II in the Safety Manual.			
⁴ Depending on methode of proof test.			
Declaration			
<input checked="" type="checkbox"/>	Our internal company quality management system ensures information on safety-related systematic faults which become evident in the future		

*1) FIT = Failure In Time, Number of failures per 10⁹ h





*2) PTC = Proof Test Coverage (Diagnostic coverage for proof test)

2/2

A0025623

General

The components can be operated as different versions:

- Version II (→  6)
One Soliphant with a 1-channel Nivotester, for the activation of an actuator or a safety-related PLC via switching contacts, for instance
- Version III (→  7)
One Soliphant with a 3-channel Nivotester, switching contacts are switched in series
- Version IV (→  8)
Two Soliphant devices with a 3-channel Nivotester, switching contacts are switched in series
- Version V (→  10)
Three Soliphant devices with a 3-channel Nivotester; evaluation is performed in a safety-related PLC, for example
- Version VI (→  12)
Three Soliphant devices with a 3-channel Nivotester, only channel 1 has a SIL-specific monitoring function. Channels 2 and 3 are used for level control of the same level (e.g. Δs). This level control may not then be considered as a safety measure as part of functional safety according to EN 61508.

NOTICE**Measuring another, independent level (e.g. in a second tank)**

- ▶ The remaining channels may not be used for other levels.





Other safety-related characteristic values

Please note the following for the tables below:

- A common cause factor $\beta = 10\%$ has been assumed in the calculations indicated below.
- For multi-channel systems, the PFD_{avg} values already contain common cause failures for the specific wiring scheme.
- The PFD_{avg} values only apply to the particular wiring scheme for which the values have been calculated. They are not a suitable basis for making calculations for other wiring schemes. The use of NC contacts instead of NO contacts, in particular, is not permitted for operation according to SIL specifications.
- The wiring scheme indicates the number of devices and the circuitry of the level relay contacts (open when required (demand mode)).
- If there are several devices in a wiring scheme, all the devices have the same settings shown.
- The tables show safety-related values and wiring options for the measuring system.
- FIT = Failure in Time, 1 FIT = 10^{-9} 1/h.

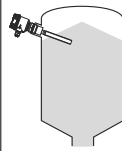

Specific functional safety parameters:

Version II: Soliphant M/S; 1-channel Nivotester FTL325P

Characteristics as per IEC 61508	Value
Safety function	MAX
Example	
Wiring scheme	 <p><i>A Other safety equipment e.g. actuator/safety-related PLC</i></p>
SIL	2
HFT	0
Device type	B
Mode of operation	Low demand mode
SFF	94 %
MTTR	8 h
$\lambda_{sd}^{1)}$	157 FIT
λ_{su}	817 FIT
λ_{dd}	40 FIT
λ_{du}	65 FIT
$PF_{D_{avg}}$ for $T_1 = 1$ year	2.83×10^{-4}
MTBF	106 years
Diagnostic test interval ²⁾	≤ 60 s
Fault reaction time ³⁾	≤ 3 s
System reaction time ⁴⁾	Switching delay  : 0.5 s (free > covered); 1 s (covered > free) Switching delay  : 5 s (free > covered and covered > free)
PTC test sequence A ⁵⁾	97 %
PTC test sequence B ⁶⁾	63 %

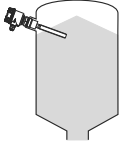
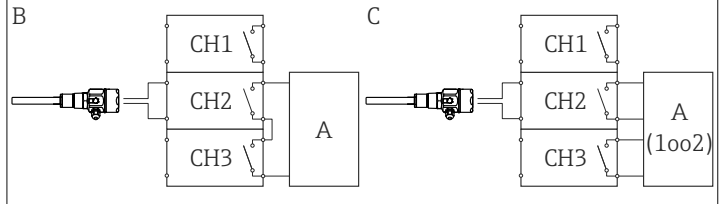

- 1) This value takes into account failure types relevant to the function of the electronic components according to Siemens SN29500.
- 2) During this time, all diagnostic functions are executed at least once.
- 3) Time between error detection and error response.
- 4) Step response time as per DIN EN 61298-2.
- 5) Proof test coverage when the level is approached, or when the sensor is removed and the tines are immersed in a medium of similar density and granulation.
- 6) Proof test coverage when simulation is performed on the Nivotester by activating the test button.

Version III: Soliphant M/S; 3-channel Nivotester FTL325P, CH2 and CH3 in series

Characteristics as per IEC 61508	Value
Safety function	MAX
Example	
Wiring scheme	 <p>A Other safety equipment e.g. actuator/safety-related PLC B Possibility 1 C Possibility 2; 1oo2 assessment</p>
SIL	2
HFT	0
Device type	B
Mode of operation	Low demand mode
SFF	97 %
MTTR	8 h
$\lambda_{sd}^{1)}$	168 FIT
λ_{su}	1 020 FIT
λ_{dd}	39 FIT
λ_{du}	34 FIT
PFDA _{avg} for T ₁ = 1 year	1.49 x 10 ⁻⁴
MTBF	91 years
Diagnostic test interval ²⁾	≤60 s
Fault reaction time ³⁾	≤3 s
System reaction time ⁴⁾	Switching delay  :0.5 s (free > covered); 1 s (covered > free) Switching delay  :5 s (free > covered and covered > free)
PTC test sequence A ⁵⁾	98 %
PTC test sequence B ⁶⁾	75 %

- 1) This value takes into account failure types relevant to the function of the electronic components according to Siemens SN29500.
- 2) During this time, all diagnostic functions are executed at least once.
- 3) Time between error detection and error response.
- 4) Step response time as per DIN EN 61298-2.
- 5) Proof test coverage when the level is approached, or when the sensor is removed and the tines are immersed in a medium of similar density and granulation.
- 6) Proof test coverage when simulation is performed on the Nivotester by activating the test button.

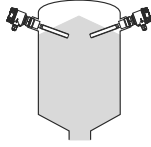
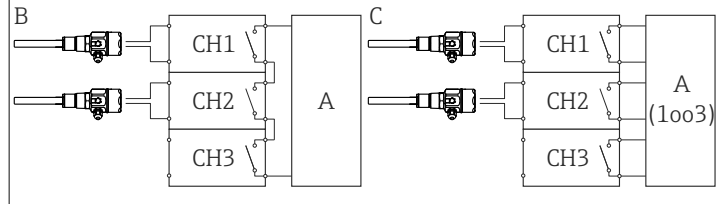
Version IV: 2 Soliphant M/S; 3-channel Nivotester FTL325P

Characteristics as per IEC 61508	Value
Safety function	MAX
Example	
Wiring scheme	 <p>A Other safety equipment e.g. actuator/safety-related PLC B Possibility 1 C Possibility 2; 1oo3 assessment</p>
SIL	2
HFT	1
Device type	B
Mode of operation	Low demand mode
SFF	99 %
MTTR	8 h
$\lambda_{sd}^{1)}$	402 FIT
λ_{su}	1 637 FIT
λ_{dd}	2 FIT
λ_{du}	12 FIT
PFDA _{avg} for T ₁ = 1 year	5.11 x 10 ⁻⁵
MTBF	56 years
Diagnostic test interval ²⁾	≤60 s
Fault reaction time ³⁾	≤3 s
System reaction time ⁴⁾	Switching delay  :0.5 s (free > covered); 1 s (covered > free) Switching delay  :5 s (free > covered and covered > free)
PTC test sequence A ⁵⁾	97 %
PTC test sequence B ⁶⁾	63 %



- 1) This value takes into account failure types relevant to the function of the electronic components according to Siemens SN29500.
- 2) During this time, all diagnostic functions are executed at least once.
- 3) Time between error detection and error response.
- 4) Step response time as per DIN EN 61298-2.
- 5) Proof test coverage when the level is approached, or when the sensor is removed and the tines are immersed in a medium of similar density and granulation.
- 6) Proof test coverage when simulation is performed on the Nivotester by activating the test button.



The failure rates are based on an analysis in accordance with DIN EN 61508-6: 2011-02, Table D.4, "Using the β -factor to calculate the probability of failure in an E/E/PE safety-related system due to common cause failures". The calculation gives a β -factor of 10 %. This factor is based on the failure rates indicated above. If additional measures are implemented during installation to prevent common cause errors as defined in Table D.1, the β -factor can possibly be reduced to 5 %. Possible measures are:

- Sensors installed in a physically separate location
- Wiring routed separately between the Soliphant and Nivotester
- Separate protection from environmental influences: impact, sunshine, EMC protection and/or overvoltage
- Use of different sensor materials, and combination of high-temperature and normal version

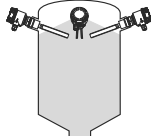
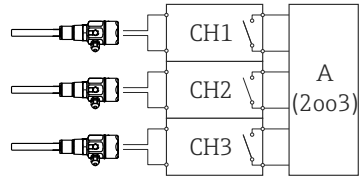
Version IV: 3 Soliphant M/S; 3-channel Nivotester FTL325P

Characteristics as per IEC 61508	Value
Safety function	MAX
Example	
Wiring scheme	 <p><i>A Other safety equipment e.g. actuator/safety-related PLC; 2oo3 assessment</i></p>
SIL	2
HFT	1
Device type	B
Mode of operation	Low demand mode
SFF	99 %
MTTR	8 h
λ_{sd} ¹⁾	598 FIT
λ_{su}	1 984 FIT
λ_{dd}	3 FIT
λ_{du}	14 FIT
PFD _{avg} for T ₁ = 1 year	5.96 x 10 ⁻⁵
MTBF	44 years
Diagnostic test interval ²⁾	≤60 s
Fault reaction time ³⁾	≤3 s
System reaction time ⁴⁾	Switching delay  :0.5 s (free > covered); 1 s (covered > free) Switching delay  :5 s (free > covered and covered > free)
PTC test sequence A ⁵⁾	97 %
PTC test sequence B ⁶⁾	63 %



- 1) This value takes into account failure types relevant to the function of the electronic components according to Siemens SN29500.
- 2) During this time, all diagnostic functions are executed at least once.
- 3) Time between error detection and error response.
- 4) Step response time as per DIN EN 61298-2.
- 5) Proof test coverage when the level is approached, or when the sensor is removed and the tines are immersed in a medium of similar density and granulation.
- 6) Proof test coverage when simulation is performed on the Nivotester by activating the test button.



The failure rates are based on an analysis in accordance with DIN EN 61508-6: 2011-02, Table D.4, "Using the β -factor to calculate the probability of failure in an E/E/PE safety-related system due to common cause failures". The calculation gives a β -factor of 10 %. This factor is based on the failure rates indicated above. If additional measures are implemented during installation to prevent common cause errors as defined in Table D.1, the β -factor can possibly be reduced to 5 %. Possible measures are:

- Sensors installed in a physically separate location
- Wiring routed separately between the Soliphant and Nivotester
- Separate protection from environmental influences: impact, sunshine, EMC protection and/or overvoltage
- Use of different sensor materials, and combination of high-temperature and normal version

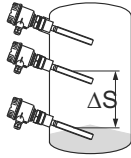
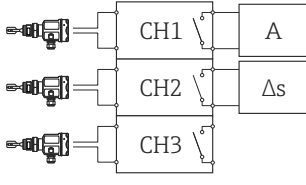
Version VI: Soliphant M/S; 3-channel Nivotester FTL325P (CH1 for SIL; CH2+CH3 e.g. for level control ΔS)

Characteristics as per IEC 61508	Value
Safety function	MAX
Example	
Wiring scheme	 <p>A Other safety equipment e.g. actuator/safety-related PLC Δs level control (not SIL)</p>
SIL	2
HFT	0
Device type	B
Mode of operation	Low demand mode
SFF	94 %
MTTR	8 h
$\lambda_{sd}^{1)}$	157 FIT
λ_{su}	817 FIT
λ_{dd}	40 FIT
λ_{du}	65 FIT
PFDAvg for $T_1 = 1$ year	2.83×10^{-4}
MTBF	106 years
Diagnostic test interval ²⁾	≤ 60 s
Fault reaction time ³⁾	≤ 3 s
System reaction time ⁴⁾	Switching delay  :0.5 s (free > covered); 1 s (covered > free) Switching delay  :5 s (free > covered and covered > free)
PTC test sequence A ⁵⁾	97 %
PTC test sequence B ⁶⁾	63 %

- 1) This value takes into account failure types relevant to the function of the electronic components according to Siemens SN29500.
- 2) During this time, all diagnostic functions are executed at least once.
- 3) Time between error detection and error response.
- 4) Step response time as per DIN EN 61298-2.
- 5) Proof test coverage when the level is approached, or when the sensor is removed and the tines are immersed in a medium of similar density and granulation.
- 6) Proof test coverage when simulation is performed on the Nivotester by activating the test button.

Useful lifetime of electrical components

The established failure rates of electrical components apply within the useful lifetime as per IEC 61508-2:2010 section 7.4.9.5 note 3.

According to DIN EN 61508-2:2011 section 7.4.9.5 national footnote N3, appropriate measures taken by the manufacturer and operator can extend the useful lifetime.

Certificate

Certificate



Nr./No.: 968/FSP 1148.00/15

Prüfgegenstand Product tested	Füllstandswächter Level monitor	Zertifikatsinhaber Certificate holder	Endress + Hauser GmbH + Co. KG Hauptstraße 1 79689 Maulburg Germany
Typbezeichnung Type designation	Liquiphant M/S with FEL56/58/57 + Nivotester FTL 325 N or FTL 325 P, Soliphant M with FEM57 + Nivotester FTL 325 P Possible device combinations see backside of this certificate.		
Prüfgrundlagen Codes and standards	IEC 61508 Parts 1-7:2010		
Bestimmungsgemäße Verwendung Intended application	Die Geräte erfüllen die Anforderungen der Prüfgrundlagen (Hardware Sicherheitsintegrität SIL 2 nach IEC 61508 und systematische Eignung SIL 3 nach IEC 61508) und können in Anwendungen bis SIL 2 (HFT=0) bzw. SIL 3 (HFT=1) nach IEC 61508 für die Sicherheitsfunktionen MIN oder MAX Füllstandsüberwachung eingesetzt werden. The devices comply with the requirements of the relevant standards (Hardware safety integrity SIL 2 acc. to IEC 61508 and systematic capability SIL 3 acc. to IEC 61508) and can be used in applications up to SIL 2 (HFT=0) resp. SIL 3 (HFT=1) acc. to IEC 61508 for the safety functions MIN or MAX level monitoring.		
Besondere Bedingungen Specific requirements	Die Hinweise in der zugehörigen Betriebsanleitung und dem Sicherheitshandbuch sind zu beachten. The instructions of the associated Operating Manual and Safety Manual shall be considered.		

Gültig bis / Valid until 2020-10-05

Der Ausstellung dieses Zertifikates liegt eine Prüfung zugrunde, deren Ergebnisse im Bericht Nr. 968/FSP 1148.00/15 vom 05.10.2015 dokumentiert sind.
Dieses Zertifikat ist nur gültig für Erzeugnisse, die mit dem Prüfgegenstand übereinstimmen. Es wird ungültig bei jeglicher Änderung der Prüfgrundlagen für den angegebenen Verwendungszweck.
The issue of this certificate is based upon an examination, whose results are documented in Report No. 968/FSP 1148.00/15 dated 2015-10-05.
This certificate is valid only for products which are identical with the product tested. It becomes invalid at any change of the codes and standards forming the basis of testing for the intended application.

TÜV Rheinland Industrie Service GmbH
Bereich Automation
Funktionale Sicherheit
Am Grauen Stein, 51105 Köln
Certification Body for FS-Products



Dipl.-Ing. Stephan Häb

www.fs-products.com
www.tuv.com



TÜVRheinland®
Precisely Right.

19222 12 12 EA4 © TÜV, TÜEV and TÜV are registered trademarks. Utilisation and application requires prior approval.

TÜV Rheinland Industrie Service GmbH, Am Grauen Stein, 51105 Köln / Germany
Tel.: +49 221 890-1196, Fax: +49 221 890-1333, E-Mail: industrie-service@tuv.com

A0028061

Document information





Document function

The document is part of the Operating Instructions and serves as a reference for application-specific parameters and notes.





-  General information about functional safety: SIL
- General information about SIL is available:
In the Download Area of the Endress+Hauser Internet site: www.de.endress.com/SIL

Symbols used

Safety symbols

Symbol	Meaning
	DANGER! This symbol alerts you to a dangerous situation. Failure to avoid this situation will result in serious or fatal injury.
	WARNING! This symbol alerts you to a dangerous situation. Failure to avoid this situation can result in serious or fatal injury.
	CAUTION! This symbol alerts you to a dangerous situation. Failure to avoid this situation can result in minor or medium injury.
	NOTE! This symbol contains information on procedures and other facts which do not result in personal injury.

Symbols for certain types of information

Symbol	Meaning
 A0011193	Tip Indicates additional information.
	Reference to documentation
	Reference to page
	Reference to graphic
1, 2, 3...	Series of steps

Symbols in graphics

Symbol	Meaning
1, 2, 3,...	Item numbers
1, 2, 3...	Series of steps
A, B, C, ...	Views

Supplementary device documentation*Soliphant M FTM51, FTM51, FTM52*

Documentation	Comment
Technical Information: TI00392F/00	The documentation is available on the Internet: → www.endress.com
Operating Instructions: <ul style="list-style-type: none"> ■ KA00229F/00 (FTM50, FTM51) ■ KA00230F/00 (FTM52) 	<ul style="list-style-type: none"> ■ The document is provided with the device. ■ The documentation is available on the Internet: → www.endress.com
Safety instructions depending on the selected option "Approval".	Additional safety instructions (XA, ZE) are supplied with certified device version. Please refer to the nameplate for the relevant safety instructions.

Nivotester FTL325P

Documentation	Comment
Technical Information: TI00350F/00	The documentation is available on the Internet: → www.endress.com
Operating Instructions: <ul style="list-style-type: none"> ■ KA00167F/00 (1-channel) ■ KA00168F/00 (3-channel) 	<ul style="list-style-type: none"> ■ The document is provided with the device. ■ The documentation is available on the Internet: → www.endress.com
Safety instructions depending on the selected option "Approval".	Additional safety instructions (XA, ZE) are supplied with certified device version. Please refer to the nameplate for the relevant safety instructions.

 This supplementary Safety Manual applies in addition to the Operating Instructions, Technical Information and ATEX Safety Instructions. The supplementary device documentation must be observed during installation, commissioning and operation. The requirements specific for the protection function are described in this Safety Manual.

Permitted devices types

The details pertaining to functional safety in this manual relate to the device versions listed below and are valid as of the specified firmware and hardware versions. Unless otherwise specified, all the following versions can also be used for protective systems. A modification process according to IEC 61508 is applied for device changes.

Valid device versions for safety-related use: Soliphant M FTM50, FTM51, FTM52

Ordering feature	Designation	Option
010	Approval	All
020	Process connection	All
030	Material; surface refinement	All
040	Fork; bulk density	All
050	Electronics; output	7 FEM57; 2-wire PFM
060	Type of probe	All
070	Housing	All
080	Cable entry	All
090	Additional options 1	<ul style="list-style-type: none"> ▪ R Glass cover, SIL Declaration of Conformity ▪ S SIL Declaration of Conformity
100	Additional options 2	All
995	Marking	All

- Valid firmware version: 01.01.00 and higher
- Valid hardware version: 01.00 and higher

Valid device versions for safety-related use: Nivotester FTL325P

Ordering feature	Designation	Option
010	Approval	<ul style="list-style-type: none"> ▪ G ATEX II 3(1)G Ex nC/A [ia] IIC T4, SIL, IECEx Zone 2 ▪ H ATEX II (1)GD [EEEx ia] IIC, WHG, SIL, IECEx [Ex ia] IIC ▪ N NEPSI [Ex ia] IIC, SIL ▪ P FM IS Cl. I, II, III Div. 1 Gr. A-G, SIL ▪ T CSA IS Cl. I, II, III Div. 1 Gr. A-G, SIL ▪ W TIIS Ex ia IIC, SIL, labeling in Japan ▪ 2 INMETRO [Ex ia Ga] IIC, SIL ▪ 8 EAC [Ex ia Ga] IIC SIL; EAC [Ex ia Da] IIC, SIL
020	Housing	<ul style="list-style-type: none"> ▪ 1 Rail mounting, 22.5 mm, 1-channel ▪ 3 Rail mounting, 45mm, 3-channel
030	Power connection	All
040	Switch output	<ul style="list-style-type: none"> ▪ 1 1x SPDT level + 1x SPST alarm ▪ 3 3x SPDT level + 1x SPST alarm
995	Marking	All

Valid hardware version: 02.00 and higher

SIL label on the nameplate



SIL certified devices are marked with the following symbol on the nameplate: 

Safety function

Definition of the safety function

The measuring system's safety functions are:
Maximum point level monitoring (overflow protection)



For information on the choice of operating mode, see → 19.

Restrictions for use in safety-related applications

- The measuring system must be used correctly for the specific application, taken into account the medium properties and ambient conditions. Carefully follow instructions pertaining to critical process situations and installation conditions from the Operating Instructions. The application-specific limits must be observed.
- The specifications from the Operating Instructions must not be exceeded, (→ 15).

Density of the medium

Operation is only permitted with bulk solids:
Depending on the configured density setting and the fork length, the density of the bulk material must be as follows:

- Over 50 g/l with standard fork and with switch position "high bulk density" ●.
- Over 10 g/l with standard fork and with switch position "low bulk density" ●.
- Over 200 g/l with short fork and with switch position "high bulk density" ●.
- Over 50 g/l with short fork and with switch position "low bulk density" ●.



- There is no maximum density for the bulk solids.
Recommendation: for heavy bulk solids, select the "high bulk density" setting to reduce the risk of false alarms.
- For more information on the levels of diagnostic coverage, refer to IEC 61508-2:2010 Appendix A.2, Comment 2 and Table A.1.

Gas phase

There must be a gas phase or a vacuum above the bulk solids. The detection of boundary layers, e.g. to liquids, is not permitted!

Wall distance



Recommendation: select the clearance to the wall such that bulk solids cannot get jammed between the vessel wall and the fork. This prevents the system from not quitting the demand mode.

Corrosion

The device may only be used in media to which the wetted parts used are resistant. Corrosion can have the effect that the demand mode of the safety function is not detected and the device will not switch as intended.



Corrosion is detected with low diagnostic coverage in the event of a low bulk density and with diagnostics switched ON.

If coated sensors are used, measures must be taken to ensure there is no damage during installation and operation.

Abrasion

The device may not be used or cleaned in abrasive media. Material removal can have the effect that the demand mode is not detected.



Abrasion is detected with low diagnostic coverage in the event of a low bulk density and with diagnostics switched ON.

External vibration

In systems exposed to strong external vibrations, e.g. in the 50 to 600 Hz range (acceleration spectral density $>1 \text{ (m/s}^2\text{)}^2\text{/Hz}$) or ultrasound with cavitation, the safety function must be verified by simulating a demand mode prior to operation. Accidental switchings may sporadically occur if a strong frequency from an external source is superimposed on the frequency of the tuning fork.

EMC compatibility

The device is certified in accordance with IEC 61326-3-2 and is therefore suitable for safety-related, industrial applications in a specified electromagnetic environment. If the specified electromagnetic ambient conditions are exceeded, the switch status might not be reliably detected. An unshielded cable up to 1 000 m (3 281 ft) long can be used between the devices in these environmental conditions. Electromagnetic interference immunity can be further improved by using shielded cables.

Mounting the Soliphant M FTM51 with sliding sleeve

Particular care is required when mounting the device with a pipe extension in conjunction with a sliding sleeve. The operator must implement appropriate measures to ensure that the switch point is not tampered with or that any tampering is reliably detected.

Use in safety instrumented systems

Device behavior during operation

Behavior of device during power-up

The behavior of the device during power-up is described in the relevant Operating Instructions (→  15).

Device behavior in safety function demand mode

The safety-related output signal consists of one switching contact per channel:
Channel 1: terminal 4 and 5

With the 3-channel Nivotester, also:

- Channel 2: terminal 22 and 23
- Channel 3: terminal 26 and 27



The switching contacts work with quiescent current safety; they are closed in the GOOD state.

The switching contacts are de-energized in the following situations:

- In demand mode
- If a fault is detected
- If the supply voltage fails

Behavior of device in event of alarms and warnings

The behavior of the device if alarms or warnings occur is described in the relevant Operating Instructions (→  15).

Device configuration for safety-related applications

The device configuration may not be changed if SIL operation is in progress.

Recommendation: perform a proof test after configuring to ensure that the safety function is working correctly.

Configuring the Soliphant

 Switch to switch the self-test on and off

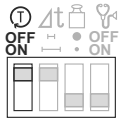
Switch representation	Function	Switch position	Start behavior
 A0025600	OFF	Top	~ 1 s 0 Hz
	ON	Bottom	<ul style="list-style-type: none"> ■ ~ 3 s 0 Hz ■ ~ 4 s 150 Hz (covered = demand mode) ■ ~ 3 s 50 Hz (free = potentially dangerous)

WARNING

The safety function is disabled during the self-test!

A potentially dangerous output signal is output temporarily.

- ▶ Measures must be taken to guarantee the safety function during this period.

Δt Switch for switching delay

Switch representation	Function	Switch position	Switching delay
 A0025586	↔	Top	0.5 s (free > covered); 1 s (covered > free)
	↔	Bottom	5 s (free > covered and covered > free)

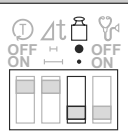

 Switch for bulk density / density

Switch representation	Function	Switch position	Standard fork density	Short fork density
 A0025583	●	Top	Over 50 g/l	Over 200 g/l
	•	Bottom	Over 10 g/l	Over 50 g/l

 The switch position depends on the individual medium (→  17).

 Switch for diagnosis for abrasion

Switch representation	Function	Switch position	High bulk density ●	Low bulk density •
 A0025581	OFF	Top	Off	Off
	ON	Bottom	Off (only indicated by LED on electronic insert)	On (relay de-energizes in the event of an error)

-  ■ The function depends on the selected density setting (→  17).
- The switch position is not relevant for SIL since the diagnostics function does not have the high level of diagnostics coverage which is required for SIL 2 (→  17).

Configuring the Nivotester

Mode of operation	Version	Switch				
		Channel 1 1	Fault message 2	Channel 2 ¹⁾ 2	Channel 3 ¹⁾ 1	MODE ¹⁾
MAX	II	MAX	With	Not applicable		
	III		None	MAX	MAX	2
	IV		With			2
	V					3
	VI					1

1) Only for 3-channel Nivotester FTL325P

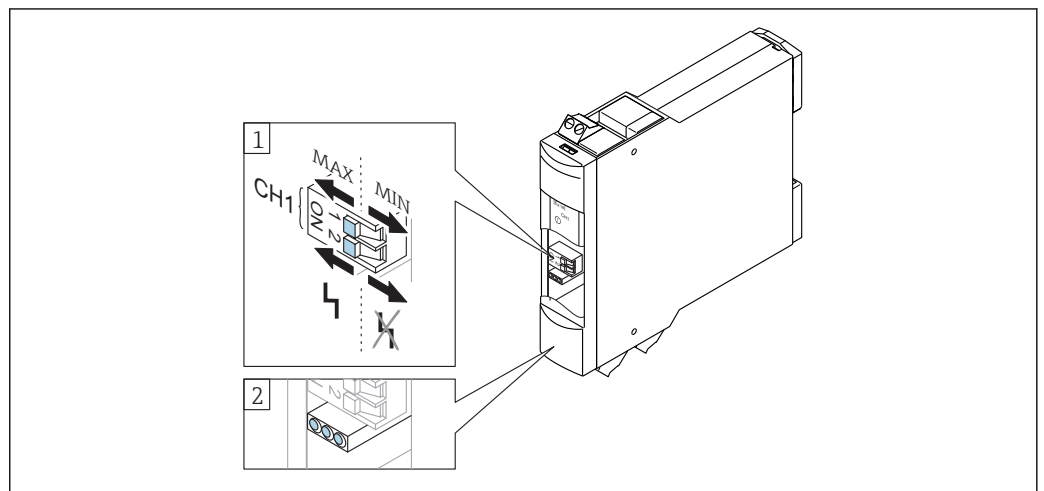

A0026315

1 Operating and display element, 1-channel Nivotester FTL325P

1 DIL switch: MAX/MIN position (1), fault on/off position (2)

2 Light emitting diodes (LEDs)

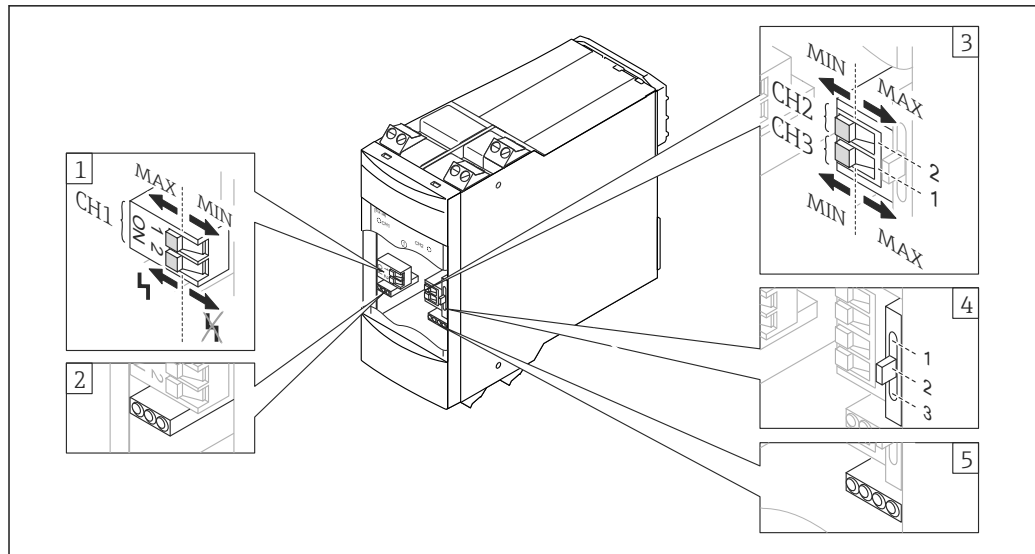

A0026422

☒ 2 Operating and display element, 3-channel Nivotester FTL325P

- 1 DIL switch: MAX/MIN position (1), fault on/off position (2)
- 2 Light emitting diodes (LEDs)
- 3 DIL switch: MAX/MIN position
- 4 Switch for functions: Δs , e.g. pump control (1), two level relays (2), individual channels (3)
- 5 Light emitting diodes (LEDs)

Proof-testing

Check the operativeness and safety of safety functions at appropriate intervals! The operator must determine the time intervals.

The values and figures in the "Additional safety-related characteristic values" section can be used to this end, → ☒ 5. The check must be carried out in such a way that it is proven that the protective system functions perfectly in interaction with all components.

Proof-testing can be performed as follows:

- Test sequence A:
Approach the bulk solid or remove and immerse in a medium of similar density and granulation.
- Test sequence B:
Activate simulation by pressing the test button on the Nivotester.

NOTICE

Ensuring correct device sealing!

- ▶ You must also check and ensure that all cover seals and cable entries are sealing correctly.

Procedure of the proof-test

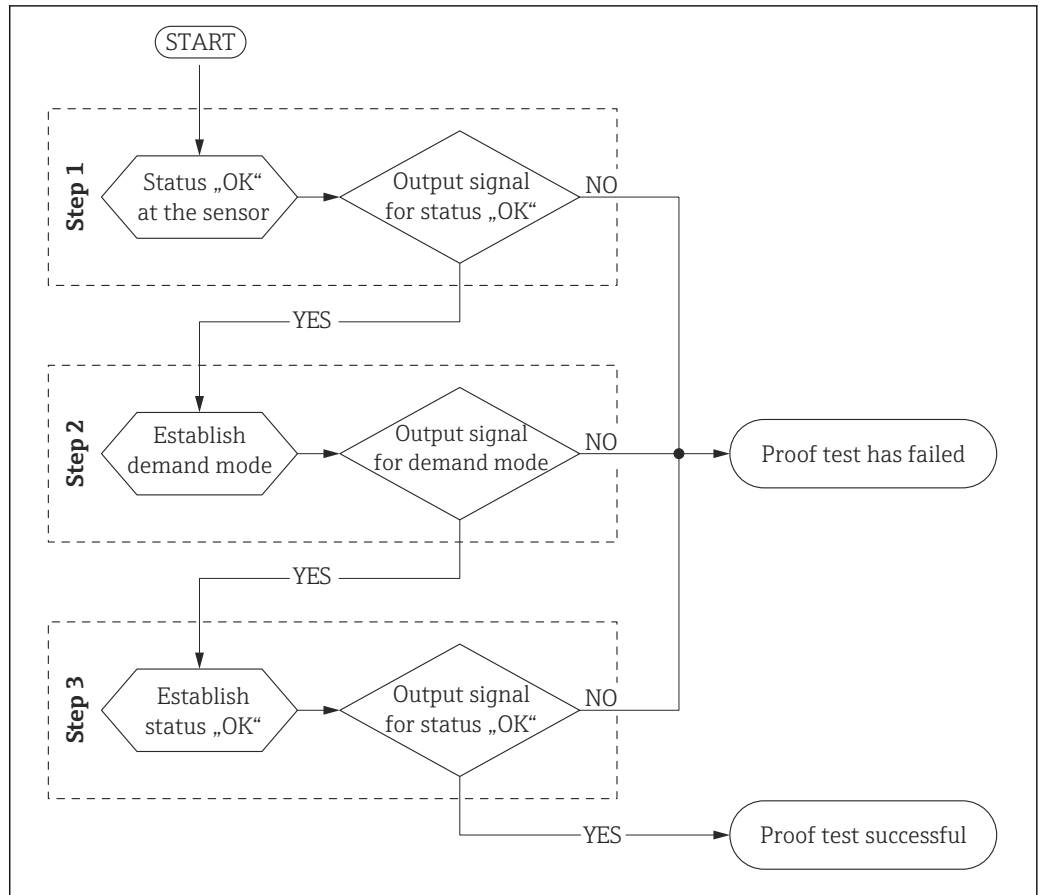

A0026161-EN

A demand mode or a fault takes absolute precedence over the proof test and in the measuring system safety path. For this reason, the demand mode must first be ended or the fault rectified before the proof test can commence. It is advisable to also check that the alarm relay (terminal 15 and 16) has not de-energized (no fault is present) at the start of the proof test (step 1).

i The proof test can and may only be performed if the device state is GOOD.

The status of the individual output signal is indicated by a measuring device or a downstream component of the safety path (e.g. safety-related PLC, actuator). For more information, → 29.

i It is advisable to document the steps of the proof test (→ 30).

	Mode of operation
	MAX
Approach the level	Test sequence A (→ 24)
Remove and immerse in a medium of similar density and viscosity	
Activate simulation by pressing the test button on the Nivotester.	Test sequence B (→ 26)

Test sequence A

- Approach the level or
- Remove and immerse in a medium of similar density and granulation.



Step 1

1. Lower the level or remove the tuning fork of the sensor that has been removed out of the medium until the tuning fork is completely free.
 - ↳ If it is not possible to do this with the original medium, a medium of a similar density and granulation must be used.
2. Check the status of the safety contacts.

Terminal	Version				
	II	III	IV	V	VI
4+5	Closed	Not applicable	Closed	Closed	Closed
22+23	Not applicable	Closed	Closed	Closed	Not applicable
26+27	Not applicable	Closed	Closed	Closed	Not applicable

i If one or more safety contacts are open, a fault has occurred in the safety path. The proof test has not been passed and must be aborted.

Step 2

1. Raise the level or immerse the tuning fork of the sensor that has been removed into the medium until the tuning fork is fully covered.
2. In the event of a switching delay $\text{I} \dashv$ once the fork is covered (plus a response time of approx. 1 s), check the status of the safety contacts (\rightarrow  19).
3. In the event of a switching delay $\text{I} \dashv \text{I}$ once the fork is covered (plus a response time of approx. 5 s), check the status of the safety contacts (\rightarrow  19).

Terminal	Version				
	II	III	IV	V	VI
4+5	Open	Not applicable	Open	Open	Open
22+23	Not applicable	Open	Open	Open	Not applicable
26+27	Not applicable	Open	Open	Open	Not applicable

i If one or more safety contacts are closed, a fault has occurred in the safety path. The proof test has not been passed and must be aborted.

Step 3

1. Re-install the sensor that was removed.
2. Restore the GOOD state by fully exposing the tuning fork.
3. Once the fork is exposed, in the event of a switching delay $\text{I} \dashv$ (plus a response time of approx. 1 s) or in the event of a switching delay $\text{I} \dashv \text{I}$ (plus a response time of approx. 5 s), check the status of the safety contacts.
4. Once the voltage is restored when the self-test is OFF (plus a response time of approx. 3 s) or once the voltage is restored when the self-test is ON (plus a response time of approx. 10 s), check the status of the safety contacts.

Terminal	Version				
	II	III	IV	V	VI
4+5	Closed	Not applicable	Closed	Closed	Closed
22+23	Not applicable	Closed	Closed	Closed	Not applicable
26+27	Not applicable	Closed	Closed	Closed	Not applicable

 If one or more safety contacts are open, a fault has occurred in the safety path. The proof test has not been passed and must be aborted.

Test sequence B

Activate simulation by pressing the test button on the Nivotester.

Step 1

- ▶ Check the status of the safety contacts.

Terminal	Version				
	II	III	IV	V	VI
4+5	Closed	Not applicable	Closed	Closed	Closed
22+23	Not applicable	Closed	Closed	Closed	Not applicable
26+27	Not applicable	Closed	Closed	Closed	Not applicable

 If one or more safety contacts are open, a fault has occurred in the safety path. The proof test has not been passed and must be aborted.

Step 2

1. Press and hold the test button on the Nivotester.
2. Check the status of the safety contacts.

Terminal	Version				
	II	III	IV	V	VI
4+5	Open	Not applicable	Open	Open	Open
22+23	Not applicable	Open	Open	Open	Not applicable
26+27	Not applicable	Open	Open	Open	Not applicable

 If one or more safety contacts are closed, a fault has occurred in the safety path. The proof test has not been passed and must be aborted.









Step 3

1. Release the test button on the Nivotester.
2. The safety contacts switch once the voltage is restored when the self-test is OFF (plus a response time of approx. 3 s) or once the voltage is restored when the self-test is ON (plus a response time of approx. 10 s).

Terminal	Version				
	II	III	IV	V	VI
4+5	Closed	Not applicable	Closed	Closed	Closed
22+23	Not applicable	Closed	Closed	Closed	Not applicable
26+27	Not applicable	Closed	Closed	Closed	Not applicable

 If one or more safety contacts are open, a fault has occurred in the safety path. The proof test has not been passed and must be aborted.

Life cycle

Requirements for personnel	<p>The personnel for installation, commissioning, diagnostics, repair and maintenance must meet the following requirements:</p> <ul style="list-style-type: none"> ▪ Trained, qualified specialists must have a relevant qualification for this specific function and task ▪ Are authorized by the plant owner/operator ▪ Are familiar with federal/national regulations ▪ Before beginning work, the specialist staff must have read and understood the instructions in the manuals and supplementary documentation as well as in the certificates (depending on the application) ▪ Follow instructions and comply with basic conditions <p>The operating personnel must meet the following requirements:</p> <ul style="list-style-type: none"> ▪ Are instructed and authorized according to the requirements of the task by the facility's owner-operator ▪ Follow the instructions in this manual 																						
Installation	<p>The installation of the device is described in the relevant Operating Instructions (→  15).</p> <p>As the application conditions affect the reliability of the measurement, please pay attention to the notes in the Technical information and Operating Instructions (→  15).</p>																						
Operation	Mandatory settings and information for the safety function (→  19).																						
Maintenance	<p>Maintenance information, .</p> <p> Alternative monitoring measures must be taken to ensure process safety during configuration, proof-testing and maintenance work on the device.</p>																						
Repair	<p> Repair means a one-to-one replacement of components. Repairs on the devices must always be carried out by Endress+Hauser. Safety functions cannot be guaranteed if repairs are carried out by anybody else.</p> <p>Exceptions:</p> <p>Qualified personnel may replace the following components on the condition that original spare parts are used and the relevant Installation Instructions are observed:</p>																						
<table border="1"> <thead> <tr> <th data-bbox="496 1267 799 1301">Component</th> <th data-bbox="799 1267 1102 1301">Installation Instructions</th> <th data-bbox="1102 1267 1546 1301">Checking the device after repair</th> </tr> </thead> <tbody> <tr> <td data-bbox="496 1301 799 1357">Electronic insert</td> <td data-bbox="799 1301 1102 1357">EA01050F</td> <td data-bbox="1102 1301 1546 1357" rowspan="9">Proof-testing, see the "Proof-testing" section (→  22)¹⁾</td> </tr> <tr> <td data-bbox="496 1357 799 1480">Housing cover T13</td> <td data-bbox="799 1357 1102 1480"> <ul style="list-style-type: none"> ▪ EA01049F/00 (electronics) ▪ EA01049F/00 (inspection glass) ▪ EA01050F/00 (connection) </td> </tr> <tr> <td data-bbox="496 1480 799 1525">Housing cover F13</td> <td data-bbox="799 1480 1102 1525">EA01046F/00</td> </tr> <tr> <td data-bbox="496 1525 799 1570">Housing cover F15</td> <td data-bbox="799 1525 1102 1570">EA01034F/00</td> </tr> <tr> <td data-bbox="496 1570 799 1615">Housing cover F16</td> <td data-bbox="799 1570 1102 1615">EA01035F/00</td> </tr> <tr> <td data-bbox="496 1615 799 1659">Housing cover F17</td> <td data-bbox="799 1615 1102 1659">EA01036F/00</td> </tr> <tr> <td data-bbox="496 1659 799 1704">Housing cover F27</td> <td data-bbox="799 1659 1102 1704">EA01047F/00</td> </tr> <tr> <td data-bbox="496 1704 799 1749">Cover seal F15</td> <td data-bbox="799 1704 1102 1749">KA00620F/00</td> </tr> <tr> <td data-bbox="496 1749 799 1783">Sensor</td> <td data-bbox="799 1749 1102 1783">KA00628F/00</td> </tr> </tbody> </table>		Component	Installation Instructions	Checking the device after repair	Electronic insert	EA01050F	Proof-testing, see the "Proof-testing" section (→  22) ¹⁾	Housing cover T13	<ul style="list-style-type: none"> ▪ EA01049F/00 (electronics) ▪ EA01049F/00 (inspection glass) ▪ EA01050F/00 (connection) 	Housing cover F13	EA01046F/00	Housing cover F15	EA01034F/00	Housing cover F16	EA01035F/00	Housing cover F17	EA01036F/00	Housing cover F27	EA01047F/00	Cover seal F15	KA00620F/00	Sensor	KA00628F/00
Component	Installation Instructions	Checking the device after repair																					
Electronic insert	EA01050F	Proof-testing, see the "Proof-testing" section (→  22) ¹⁾																					
Housing cover T13	<ul style="list-style-type: none"> ▪ EA01049F/00 (electronics) ▪ EA01049F/00 (inspection glass) ▪ EA01050F/00 (connection) 																						
Housing cover F13	EA01046F/00																						
Housing cover F15	EA01034F/00																						
Housing cover F16	EA01035F/00																						
Housing cover F17	EA01036F/00																						
Housing cover F27	EA01047F/00																						
Cover seal F15	KA00620F/00																						
Sensor	KA00628F/00																						
1) Additional country-specific regulations and tests must be observed.																							
<p>In the event of failure of a SIL-labeled Endress+Hauser device, which has been operated in a protection function, the "Declaration of Contamination and Cleaning" with the corresponding note "Used as SIL device in protective system" must be enclosed when the defective device is returned. Please refer to the "Return" section of the relevant Operating Instructions →  15.</p>																							

Modification



Modifications are changes to devices with SIL capability already delivered or installed.

Modifications to devices with SIL capability are usually performed in the Endress+Hauser manufacturing center.

Modifications to devices with SIL capability onsite at the user's plant are possible following approval by the Endress+Hauser manufacturing center. In this case, the modifications must be performed and documented by an Endress+Hauser service technician.

Modifications to devices with SIL capability by the user are not permitted.

Decommissioning

For detailed information on decommissioning, see the relevant Operating Instructions →  15

Appendix

Structure of the measuring system

System components

The measuring system's devices are displayed in the following diagram (example):

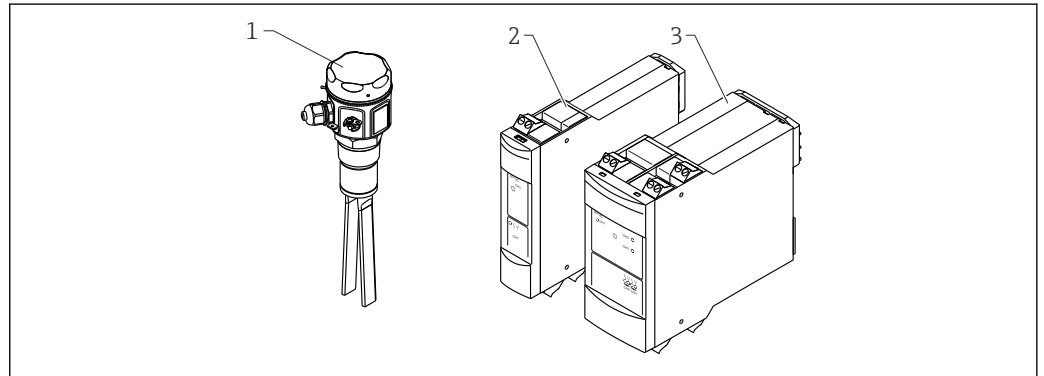

- 1 Soliphant M/S
- 2 1-channel Nivotester FTL325P
- 3 3-channel Nivotester FTL325P

Description of use as a protective system

The sensor's tuning fork vibrates at its intrinsic frequency. When the fork is covered by a bulk solid, the amplitude decreases. This loss of energy causes the current signal to change. The Maximum Detection operating mode can be selected.

MAX detection

The measuring system is used to protect against a level that is too high (e.g. overflow prevention).

i In normal operation, the tuning fork is not covered by bulk solids and the measuring system reports the "GOOD" state. If the tuning fork is covered, the device assumes the safe state and signals the demand mode.

The switch point depends on the installation. It is in the area of the tuning fork.

i Correct installation is a prerequisite for safe operation of the device.

**Commissioning or
proof test report****Report**

System-specific data							
Company							
Measuring point/TAG no.							
Facility							
Device type/Order code							
Serial no. Soliphant(en)							
Serial no. Nivotester							
Name							
Date							
Signature							
Operating mode, density range and version (please tick appropriate box)							
Bulk density	High bulk density ● over 50 g/l for standard fork, over 200 g/l for short fork						<input type="checkbox"/>
	Low bulk density • over 10 g/l for standard fork, over 50 g/l for short fork						<input type="checkbox"/>
Version	II	One Soliphant on one channel (1001)					<input type="checkbox"/>
	III	One Soliphant (1001), output relay CH2 and CH3 switched in series (1002)					<input type="checkbox"/>
	IV	Two Soliphant devices (1002), output relay CH1, CH2 and CH3 switched in series (1003)					<input type="checkbox"/>
	V	Three Soliphant devices, evaluation e.g., by PLC (2003)					<input type="checkbox"/>
	VI	Three Soliphant devices, 1 x SIL, 2 x level control (Δs)					<input type="checkbox"/>
Commissioning or proof test report							
Test sequence	A	Approach the level					<input type="checkbox"/>
		Remove and immerse in a medium of similar density and granulation					<input type="checkbox"/>
	B	Perform simulation on Nivotester by pressing test button					<input type="checkbox"/>
		Version					
Test step	Terminal	II	III	IV	V	VI	Actual value
Step 1	4+5		¹⁾				
(GOOD state)	22+23	¹⁾				²⁾	
Switch is closed	26+27	¹⁾				²⁾	
Step 2	4+5		¹⁾				
(demand mode)	22+23	¹⁾				²⁾	
Switch is open	26+27	¹⁾				²⁾	
Step 3	4+5		¹⁾				
(GOOD state)	22+23	¹⁾				²⁾	
Switch is closed	26+27	¹⁾				²⁾	
Conclusion		Passed <input type="checkbox"/>			Failed <input type="checkbox"/>		

1) Not applicable as channel is not used.

2) Not relevant for SIL, is used for level control (Δs).**Further information**

General information on functional safety (SIL) is available at:

www.de.endress.com/SIL (Germany) or www.endress.com/SIL (English) and in the Competence Brochure CP01008Z/11 "Functional Safety in the Process Industry- Risk Reduction with Safety Instrumented Systems".

Version history

Version	Changes	Valid for hardware version
SD00207F/00/EN/01.06	First version	01.00
SD00207F/00/EN/13.15	Nivotester Update to IEC 61508-2011	02.00



www.addresses.endress.com
